

## SLG46855-A

### Auto AEC-Q100 Qualified GreenPAK Programmable Mixed-Signal Matrix

#### General Description

The SLG46855-A provides a small, low power component for commonly used Mixed-Signal functions. The user creates their circuit design by programming the one time programmable (OTP) Non-Volatile Memory (NVM) to configure the interconnect logic, the IO Pins, and the macrocells of the SLG46855-A. This highly versatile device allows a wide variety of Mixed-Signal functions to be designed within a very small, low power single integrated circuit.

#### Key Features

- Two High Speed General Purpose Analog Comparators (ACMPxH)
- Two Low Power General Purpose Analog Comparators (ACMPxL)
- Two Voltage References (Vref)
  - Two Vref Outputs
- Fifteen Combination Function Macrocells
  - Three Selectable DFF/LATCH or 2-bit LUTs
  - One Selectable Programmable Pattern Generator or 2-bit LUT
  - Nine Selectable DFF/LATCH or 3-bit LUTs
  - One Selectable Pipe Delay or Ripple Counter, or 3-bit LUT
  - One Selectable DFF/LATCH or 4-bit LUTs
- Eight Multi-Function Macrocells
  - Seven Selectable DFF/LATCH or 3-bit LUTs + 8-bit Delay/Counters
  - One Selectable DFF/LATCH or 4-bit LUT + 16-bit Delay/Counter
- Serial Communications
  - I<sup>2</sup>C Protocol Interface
- Programmable Delay with Edge Detector Output
- Deglitch Filter or Edge Detector
- Three Oscillators (OSC)
  - 2.048 kHz Oscillator
  - 2.048 MHz Oscillator
  - 25 MHz Oscillator
- Analog Temperature Sensor
- Power-On Reset (POR)
- Read Back Protection (Read Lock)
- Power Supply
  - 2.5 V (±8 %) to 5 V (±10 %)
- Ambient Operating Temperature Range: -40 °C to 105 °C
- RoHS Compliant/Halogen-Free
- Available Package
  - 14-pin FCQFN: 3.0 mm x 3.0 mm x 0.55 mm, 0.65 mm pitch
- AEC-Q100 (T<sub>A</sub> = -40 °C to 105 °C) Qualified

#### Applications

- Infotainment
- Advanced Driver Assistance Systems (ADAS)
- Instrument clusters
- Audio, video, navigation

**Auto AEC-Q100 Qualified GreenPAK Programmable Mixed-Signal Matrix**
**Contents**

|  |            |
|--|------------|
| <b>General Description</b> .....                                     | <b>1</b>   |
| <b>Key Features</b> .....  | <b>1</b>   |
| <b>Applications</b> .....  | <b>1</b>   |
| <b>1 Block Diagram</b> .....   | <b>7</b>   |
| <b>2 Pinout</b> .....  | <b>8</b>   |
| 2.1 Pin Configuration - FCQFN- 14L .....                             | 8          |
| <b>3 Characteristics</b> .....                                       | <b>12</b>  |
| 3.1 Absolute Maximum Ratings .....                                   | 12         |
| 3.2 Electrostatic Discharge Ratings .....                            | 12         |
| 3.3 Recommended Operating Conditions .....                           | 12         |
| 3.4 Electrical Characteristics .....                                 | 13         |
| 3.5 I <sup>2</sup> C Pins Electrical Characteristics .....           | 16         |
| 3.6 Macrocells Current Consumption .....                             | 20         |
| 3.7 Timing Characteristics .....                                     | 20         |
| 3.8 Counter/Delay Characteristics .....                              | 24         |
| 3.9 Oscillator Characteristics .....                                 | 25         |
| 3.10 ACMP Characteristics .....                                      | 25         |
| 3.11 Analog Temperature Sensor Characteristics .....                 | 29         |
| <b>4 User Programmability</b> .....                                  | <b>31</b>  |
| <b>5 IO Pins</b> .....   | <b>32</b>  |
| 5.1 GPIO Pins .....  | 32         |
| 5.2 GPI Pins .....   | 32         |
| 5.3 GPO Pins .....   | 32         |
| 5.4 Pull-Up/Down Resistors .....                                     | 32         |
| 5.5 Fast Pull-up/down during Power-up .....                          | 32         |
| 5.6 GPI Structure .....  | 33         |
| 5.7 GPIO with I <sup>2</sup> C Mode IO Structure .....               | 34         |
| 5.8 Matrix OE IO Structure .....                                     | 35         |
| 5.9 GPO Structure .....  | 37         |
| 5.10 IO Typical Performance .....                                    | 38         |
| <b>6 Connection Matrix</b> .....                                     | <b>43</b>  |
| 6.1 Matrix Input Table .....   | 44         |
| 6.2 Matrix Output Table .....  | 46         |
| 6.3 Connection Matrix Virtual Inputs .....                           | 49         |
| 6.4 Connection Matrix Virtual Outputs .....                          | 49         |
| <b>7 Combination Function Macrocells</b> .....                       | <b>50</b>  |
| 7.1 2-Bit LUT or D Flip-Flop Macrocells .....                        | 50         |
| 7.2 2-bit LUT or Programmable Pattern Generator .....                | 53         |
| 7.3 3-Bit LUT or D Flip-Flop with Set/Reset Macrocells .....         | 55         |
| 7.4 4-Bit LUT or D Flip-Flop with Set/Reset Macrocell .....          | 64         |
| 7.5 3-Bit LUT or Pipe Delay/Ripple Counter Macrocell .....           | 66         |
| <b>8 Multi-Function Macrocells</b> .....                             | <b>70</b>  |
| 8.1 3-Bit LUT or DFF/Latch with 8-Bit Counter/Delay Macrocells ..... | 70         |
| 8.2 4-Bit LUT or DFF/Latch with 16-Bit Counter/Delay Macrocell ..... | 80         |
| 8.3 CNT/DLY/FSM Timing Diagrams .....                                | 83         |
| 8.4 Wake and Sleep Controller .....                                  | 92         |
| <b>9 Analog Comparators</b> .....                                    | <b>97</b>  |
| 9.1 ACMP0H Block Diagram .....                                       | 98         |
| 9.2 ACMP1H Block Diagram .....                                       | 99         |
| 9.3 ACMP2L Block Diagram .....                                       | 100        |
| 9.4 ACMP3L Block Diagram .....                                       | 101        |
| 9.5 ACMP Typical Performance .....                                   | 102        |
| <b>10 Programmable Delay/Edge Detector</b> .....                     | <b>105</b> |
| 10.1 Programmable Delay Timing Diagram - Edge Detector Output .....  | 105        |
| <b>11 Additional Logic Function. Deglitch Filter</b> .....           | <b>106</b> |

**Auto AEC-Q100 Qualified GreenPAK Programmable  
Mixed-Signal Matrix**

|  |            |
|--|------------|
| <b>12 Voltage Reference</b> .....  | <b>107</b> |
| 12.1 Voltage Reference Overview .....  | 107        |
| 12.2 Vref Selection Table .....  | 107        |
| 12.3 Vref Block Diagram .....  | 108        |
| 12.4 Vref Load Regulation .....  | 109        |
| <b>13 Clocking</b> .....   | <b>111</b> |
| 13.1 OSC General description .....   | 111        |
| 13.2 Oscillator0 (2.048 kHz) .....   | 112        |
| 13.3 Oscillator1 (2.048 MHz) .....   | 113        |
| 13.4 Oscillator2 (25 MHz) .....  | 114        |
| 13.5 CNT/DLY Clock Scheme .....  | 114        |
| 13.6 External Clocking .....   | 115        |
| 13.7 Oscillators Power-On Delay .....  | 116        |
| 13.8 Oscillators Accuracy .....  | 118        |
| <b>14 Power-On Reset</b> .....   | <b>120</b> |
| 14.1 General Operation .....   | 120        |
| 14.2 POR Sequence .....  | 121        |
| 14.3 Macrocells Output States During POR Sequence .....                              | 121        |
| <b>15 I<sup>2</sup>C Serial Communications Macrocell</b> .....                       | <b>124</b> |
| 15.1 I <sup>2</sup> C Serial Communications Macrocell Overview .....                 | 124        |
| 15.2 I <sup>2</sup> C Serial Communications Device Addressing .....                  | 124        |
| 15.3 I <sup>2</sup> C Serial General Timing .....                                    | 125        |
| 15.4 I <sup>2</sup> C Serial Communications Commands .....                           | 125        |
| 15.5 I <sup>2</sup> C Serial Command Register Map .....                              | 129        |
| 15.6 I <sup>2</sup> C Additional Options .....                                       | 130        |
| <b>16 Analog Temperature Sensor</b> .....  | <b>132</b> |
| <b>17 Register Definitions</b> .....   | <b>135</b> |
| 17.1 Register Map .....  | 135        |
| <b>18 Package Top Marking Definitions</b> .....                                      | <b>193</b> |
| 18.1 FCQFN 14L 3mm x 3 mm 0.65P FCD .....  | 193        |
| <b>19 Package Information</b> .....  | <b>194</b> |
| 19.1 Package Outlines for FCQFN 14L 3.0 mm x 3.0 mm x 0.55 mm 0.65P FC Package ..... | 194        |
| 19.2 FCQFN Handling .....  | 195        |
| 19.3 Soldering Information .....   | 195        |
| <b>20 Ordering Information</b> .....   | <b>195</b> |
| 20.1 Tape and Reel Specifications .....  | 195        |
| 20.2 Carrier Tape Drawing and Dimensions .....                                       | 195        |
| <b>21 Layout Guidelines</b> .....  | <b>196</b> |
| 21.1 FCQFN 14L 3 mm x 3 mm x 0.5 mm 0.65P FC Green .....                             | 196        |
| <b>Glossary</b> .....  | <b>197</b> |
| <b>Revision History</b> .....  | <b>200</b> |

**Auto AEC-Q100 Qualified GreenPAK Programmable Mixed-Signal Matrix**
**Figures**

|  |    |
|--|----|
| Figure 1: Block Diagram .....  | 7  |
| Figure 2: Steps to Create a Custom GreenPAK Device .....   | 31 |
| Figure 3: IO0 GPI Structure Diagram .....  | 33 |
| Figure 4: GPIO with I <sup>2</sup> C Mode IO Structure Diagram .....   | 34 |
| Figure 5: Matrix OE IO Structure Diagram.....  | 35 |
| Figure 6: Matrix OE IO 4x Drive Structure Diagram .....  | 36 |
| Figure 7: GPO Register OE 4x Drive Structure Diagram.....  | 37 |
| Figure 8: Typical High Level Output Current vs. High Level Output Voltage at T = 25 °C .....                       | 38 |
| Figure 9: Typical Low Level Output Current vs. Low Level Output Voltage, 1x Drive at T = 25 °C, Full Range.....    | 38 |
| Figure 10: Typical Low Level Output Current vs. Low Level Output Voltage, 1x Drive at T = 25 °C.....               | 39 |
| Figure 11: Typical Low Level Output Current vs. Low Level Output Voltage, 2x Drive at T = 25 °C, Full Range.....   | 39 |
| Figure 12: Typical Low Level Output Current vs. Low Level Output Voltage, 2x Drive at T = 25 °C.....               | 40 |
| Figure 13: Typical Low Level Output Current vs. Low Level Output Voltage, 3.2x Drive at T = 25 °C, Full Range..... | 40 |
| Figure 14: Typical Low Level Output Current vs. Low Level Output Voltage, 3.2x Drive at T = 25 °C.....             | 41 |
| Figure 15: Typical Low Level Output Current vs. Low Level Output Voltage, 4x Drive at T = 25 °C, Full Range.....   | 41 |
| Figure 16: Typical Low Level Output Current vs. Low Level Output Voltage, 4x Drive at T = 25 °C.....               | 42 |
| Figure 17: Connection Matrix.....  | 43 |
| Figure 18: Connection Matrix Example.....  | 43 |
| Figure 19: 2-bit LUT0 or DFF0.....   | 50 |
| Figure 20: 2-bit LUT1 or DFF1.....   | 51 |
| Figure 21: 2-bit LUT2 or DFF2.....   | 51 |
| Figure 22: DFF Polarity Operations.....  | 53 |
| Figure 23: 2-bit LUT3 or PGen .....  | 54 |
| Figure 24: PGen Timing Diagram .....   | 54 |
| Figure 25: 3-bit LUT0 or DFF3.....   | 56 |
| Figure 26: 3-bit LUT1 or DFF4.....   | 57 |
| Figure 27: 3-bit LUT2 or DFF5.....   | 57 |
| Figure 28: 3-bit LUT3 or DFF6.....   | 58 |
| Figure 29: 3-bit LUT4 or DFF7.....   | 58 |
| Figure 30: 3-bit LUT5 or DFF8.....   | 59 |
| Figure 31: 3-bit LUT6 or DFF9.....   | 59 |
| Figure 32: 3-bit LUT7 or DFF10.....  | 60 |
| Figure 33: 3-bit LUT8 or DFF11.....  | 60 |
| Figure 34: DFF Polarity Operations with nReset .....   | 63 |
| Figure 35: DFF Polarity Operations with nSet .....   | 64 |
| Figure 36: 4-bit LUT0 or DFF12.....  | 65 |
| Figure 37: 3-bit LUT16/Pipe Delay/Ripple Counter .....   | 67 |
| Figure 38: Example: Ripple Counter Functionality .....   | 68 |
| Figure 39: Possible Connections Inside Multi-Function Macrocell .....  | 70 |
| Figure 40: 8-bit Multi-Function Macrocells Block Diagram (3-bit LUT9/DFF13, CNT/DLY1).....                         | 71 |
| Figure 41: 8-bit Multi-Function Macrocells Block Diagram (3-bit LUT10/DFF14, CNT/DLY2).....                        | 72 |
| Figure 42: 8-bit Multi-Function Macrocells Block Diagram (3-bit LUT11/DFF15, CNT/DLY3).....                        | 73 |
| Figure 43: 8-bit Multi-Function Macrocells Block Diagram (3-bit LUT12/DFF16, CNT/DLY4).....                        | 74 |
| Figure 44: 8-bit Multi-Function Macrocells Block Diagram (3-bit LUT13/DFF17, CNT/DLY5).....                        | 75 |
| Figure 45: 8-bit Multi-Function Macrocells Block Diagram (3-bit LUT14/DFF18, CNT/DLY6).....                        | 76 |
| Figure 46: 8-bit Multi-Function Macrocells Block Diagram (3-bit LUT15/DFF19, CNT/DLY7).....                        | 77 |
| Figure 47: 4-bit LUT1 or CNT/DLY0 .....  | 81 |
| Figure 48: Delay Mode Timing Diagram, Edge Select: Both, Counter Data: 3 .....                                     | 83 |
| Figure 49: Delay Mode Timing Diagram for Different Edge Select Mode.....   | 84 |
| Figure 50: Counter Mode Timing Diagram without Two DFFs Synced Up.....   | 84 |
| Figure 51: Counter Mode Timing Diagram with Two DFFs Synced Up .....   | 85 |
| Figure 52: One-Shot Function Timing Diagram .....  | 86 |
| Figure 53: Frequency Detection Mode Timing Diagram .....   | 87 |
| Figure 54: Edge Detection Mode Timing Diagram.....   | 88 |
| Figure 55: Delayed Edge Detection Mode Timing Diagram .....  | 89 |

**Auto AEC-Q100 Qualified GreenPAK Programmable Mixed-Signal Matrix**

|   |     |
|---|-----|
| Figure 56: CNT/FSM Timing Diagram (Reset Rising Edge Mode, Oscillator is Forced On, UP = 0) for Counter Data = 3..... | 90  |
| Figure 57: CNT/FSM Timing Diagram (Set Rising Edge Mode, Oscillator is Forced On, UP = 0) for Counter Data = 3.....   | 90  |
| Figure 58: CNT/FSM Timing Diagram (Reset Rising Edge Mode, Oscillator is Forced On, UP = 1) for Counter Data = 3..... | 91  |
| Figure 59: CNT/FSM Timing Diagram (Set Rising Edge Mode, Oscillator is Forced On, UP = 1) for Counter Data = 3.....   | 91  |
| Figure 60: Counter Value, Counter Data = 3.....   | 92  |
| Figure 61: Wake/Sleep Controller.....   | 93  |
| Figure 62: Wake/Sleep Timing Diagram, Normal Wake Mode, Counter Reset is Used.....                                    | 94  |
| Figure 63: Wake/Sleep Timing Diagram, Short Wake Mode, Counter Reset is Used.....                                     | 94  |
| Figure 64: Wake/Sleep Timing Diagram, Normal Wake Mode, Counter Set is Used.....                                      | 95  |
| Figure 65: Wake/Sleep Timing Diagram, Short Wake Mode, Counter Set is Used.....                                       | 95  |
| Figure 66: ACMP0H Block Diagram.....  | 98  |
| Figure 67: ACMP1H Block Diagram.....  | 99  |
| Figure 68: ACMP2L Block Diagram.....  | 100 |
| Figure 69: ACMP3L Block Diagram.....  | 101 |
| Figure 70: Typical Propagation Delay vs. Vref for ACMPxH at T = 25 °C, Gain = 1, Hysteresis = 0.....                  | 102 |
| Figure 71: Typical Propagation Delay vs. Vref for ACMPxL at T = 25 °C, Gain = 1, Hysteresis = 0.....                  | 102 |
| Figure 72: ACMPxH Power-On Delay vs. V <sub>DD</sub> .....  | 103 |
| Figure 73: ACMPxL Power-On Delay vs. V <sub>DD</sub> .....  | 103 |
| Figure 74: ACMPxH Input Offset Voltage vs. Vref at T = -40 °C to 105 °C.....  | 104 |
| Figure 75: ACMPxL Input Offset Voltage vs. Vref at T = -40 °C to 105 °C.....  | 104 |
| Figure 76: Programmable Delay.....  | 105 |
| Figure 77: Edge Detector Output.....  | 105 |
| Figure 78: Deglitch Filter/Edge Detector.....   | 106 |
| Figure 79: Voltage Reference Block Diagram.....   | 108 |
| Figure 80: Typical Load Regulation, Vref = 320 mV, T = -40 °C to +105 °C, Buffer - Enabled.....                       | 109 |
| Figure 81: Typical Load Regulation, Vref = 640 mV, T = -40 °C to +105 °C, Buffer - Enabled.....                       | 109 |
| Figure 82: Typical Load Regulation, Vref = 1280 mV, T = -40 °C to +105 °C, Buffer - Enabled.....                      | 110 |
| Figure 83: Typical Load Regulation, Vref = 2016 mV, T = -40 °C to +105 °C, Buffer - Enabled.....                      | 110 |
| Figure 84: Oscillator0 Block Diagram.....   | 112 |
| Figure 85: Oscillator1 Block Diagram.....   | 113 |
| Figure 86: Oscillator2 Block Diagram.....   | 114 |
| Figure 87: Clock Scheme.....  | 115 |
| Figure 88: Oscillator Startup Diagram.....  | 116 |
| Figure 89: Oscillator0 Maximum Power-On Delay vs. V <sub>DD</sub> at T = 25 °C, OSC0 = 2.048 kHz.....                 | 116 |
| Figure 90: Oscillator1 Maximum Power-On Delay vs. V <sub>DD</sub> at T = 25 °C, OSC1 = 2.048 MHz.....                 | 117 |
| Figure 91: Oscillator2 Maximum Power-On Delay vs. V <sub>DD</sub> at T = 25 °C, OSC2 = 25 MHz.....                    | 117 |
| Figure 92: Oscillator0 Frequency vs. Temperature, OSC0 = 2.048 kHz.....   | 118 |
| Figure 93: Oscillator1 Frequency vs. Temperature, OSC1 = 2.048 MHz.....   | 118 |
| Figure 94: Oscillator2 Frequency vs. Temperature, OSC2 = 25 MHz.....  | 119 |
| Figure 95: Oscillators Total Error vs. Temperature.....   | 119 |
| Figure 96: POR Sequence.....  | 121 |
| Figure 97: Internal Macrocell States During POR Sequence.....   | 122 |
| Figure 98: Power-Down.....  | 123 |
| Figure 99: Basic Command Structure.....   | 125 |
| Figure 100: I <sup>2</sup> C General Timing Characteristics.....  | 125 |
| Figure 101: Byte Write Command, R/W = 0.....  | 126 |
| Figure 102: Sequential Write Command.....   | 126 |
| Figure 103: Current Address Read Command, R/W = 1.....  | 127 |
| Figure 104: Random Read Command.....  | 127 |
| Figure 105: Sequential Read Command.....  | 128 |
| Figure 106: Reset Command Timing.....   | 128 |
| Figure 107: Example of I <sup>2</sup> C Byte Write Bit Masking.....   | 131 |
| Figure 108: Analog Temperature Sensor Structure Diagram.....  | 133 |
| Figure 109: TS Output vs. Temperature, V <sub>DD</sub> = 2.3 V to 5.5 V.....  | 134 |

**Auto AEC-Q100 Qualified GreenPAK Programmable Mixed-Signal Matrix**
**Tables**

|  |     |
|--|-----|
| Table 1: Functional Pin Description .....  | 8   |
| Table 2: Pin Type Definitions .....  | 11  |
| Table 3: Absolute Maximum Ratings .....  | 12  |
| Table 4: Electrostatic Discharge Ratings .....   | 12  |
| Table 5: Recommended Operating Conditions .....  | 12  |
| Table 6: EC at TA = -40 °C to +105 °C, V <sub>DD</sub> = 2.3 V to 5.5 V Unless Otherwise Noted .....   | 13  |
| Table 7: EC of the I <sup>2</sup> C Pins for DI Mode at TA = -40 °C to +105 °C, V <sub>DD</sub> = 2.3 V to 5.5 V Unless Otherwise Noted .....          | 16  |
| Table 8: EC of the I <sup>2</sup> C Pins for DILV Mode at TA = -40 °C to +105 °C, V <sub>DD</sub> = 2.3 V to 5.5 V Unless Otherwise Noted .....        | 17  |
| Table 9: I <sup>2</sup> C Pins Timing Characteristics, DI Mode, TA = -40 °C to +105 °C, V <sub>DD</sub> = 2.3 V to 5.5 V Unless Otherwise Noted .....  | 17  |
| Table 10: I <sup>2</sup> C Pins Timing Characteristics, DILV Mode, TA = -40 °C to +105 °C, V <sub>DD</sub> = 2.3V to 5.5V Unless Otherwise Noted ..... | 18  |
| Table 11: Typical Current Estimated for Each Macrocell at TA = 25 °C .....   | 20  |
| Table 12: Typical Delay Estimated for Each Macrocell at TA = 25 °C .....   | 20  |
| Table 13: Typical Propagations Delays and Pulse Widths at TA = 25 °C .....   | 24  |
| Table 14: Typical Filter Rejection Pulse Width at TA = 25 °C .....   | 24  |
| Table 15: Typical Counter/Delay Offset at TA = 25 °C .....   | 24  |
| Table 16: Oscillators Frequency Limits, V <sub>DD</sub> = 2.3 V to 5.5 V .....   | 25  |
| Table 17: Oscillators Power-On Delay at TA = -40 °C to +105 °C, OSC Power Setting: "Auto Power-On" .....   | 25  |
| Table 18: ACMP Specifications at TA = -40 °C to +105 °C, V <sub>DD</sub> = 2.3 V to 5.5 V Unless Otherwise Noted .....                                 | 25  |
| Table 19: TS Output vs Temperature (Output Range 1), V <sub>DD</sub> = 2.3 V to 5.5 V .....  | 29  |
| Table 20: TS Output vs Temperature (Output Range 2), V <sub>DD</sub> = 2.3 V to 5.5 V .....  | 29  |
| Table 21: TS Output Error (Output Range 1), V <sub>DD</sub> = 2.3 V to 5.5 V .....   | 30  |
| Table 22: TS Output Error (Output Range 2), V <sub>DD</sub> = 2.3 V to 5.5 V .....   | 30  |
| Table 23: Matrix Input Table .....   | 44  |
| Table 24: Matrix Output Table .....  | 46  |
| Table 25: Connection Matrix Virtual Inputs .....   | 49  |
| Table 26: 2-bit LUT0 Truth Table .....   | 52  |
| Table 27: 2-bit LUT1 Truth Table .....   | 52  |
| Table 28: 2-bit LUT2 Truth Table .....   | 52  |
| Table 29: 2-bit LUT Standard Digital Functions .....   | 52  |
| Table 30: 2-bit LUT1 Truth Table .....   | 55  |
| Table 31: 2-bit LUT Standard Digital Functions .....   | 55  |
| Table 32: 3-bit LUT0 Truth Table .....   | 61  |
| Table 33: 3-bit LUT1 Truth Table .....   | 61  |
| Table 34: 3-bit LUT2 Truth Table .....   | 61  |
| Table 35: 3-bit LUT3 Truth Table .....   | 61  |
| Table 36: 3-bit LUT4 Truth Table .....   | 61  |
| Table 37: 3-bit LUT5 Truth Table .....   | 61  |
| Table 38: 3-bit LUT6 Truth Table .....   | 61  |
| Table 39: 3-bit LUT7 Truth Table .....   | 61  |
| Table 40: 3-bit LUT8 Truth Table .....   | 62  |
| Table 41: 3-bit LUT Standard Digital Functions .....   | 62  |
| Table 42: 4-bit LUT0 Truth Table .....   | 65  |
| Table 43: 4-bit LUT Standard Digital Functions .....   | 66  |
| Table 44: 3-bit LUT16 Truth Table .....  | 69  |
| Table 45: 3-bit LUT9 Truth Table .....   | 78  |
| Table 46: 3-bit LUT10 Truth Table .....  | 78  |
| Table 47: 3-bit LUT11 Truth Table .....  | 78  |
| Table 48: 3-bit LUT12 Truth Table .....  | 78  |
| Table 49: 3-bit LUT13 Truth Table .....  | 78  |
| Table 50: 3-bit LUT14 Truth Table .....  | 78  |
| Table 51: 3-bit LUT15 Truth Table .....  | 78  |
| Table 52: 4-bit LUT1 Truth Table .....   | 82  |
| Table 53: 4-bit LUT Standard Digital Functions .....   | 82  |
| Table 54: Vref Selection Table .....   | 107 |
| Table 55: Oscillator Operation Mode Configuration Settings .....   | 111 |
| Table 56: Read/Write Protection Options .....  | 129 |
| Table 57: Register Map .....   | 135 |

SLG46855-A

Auto AEC-Q100 Qualified GreenPAK Programmable Mixed-Signal Matrix

1 Block Diagram

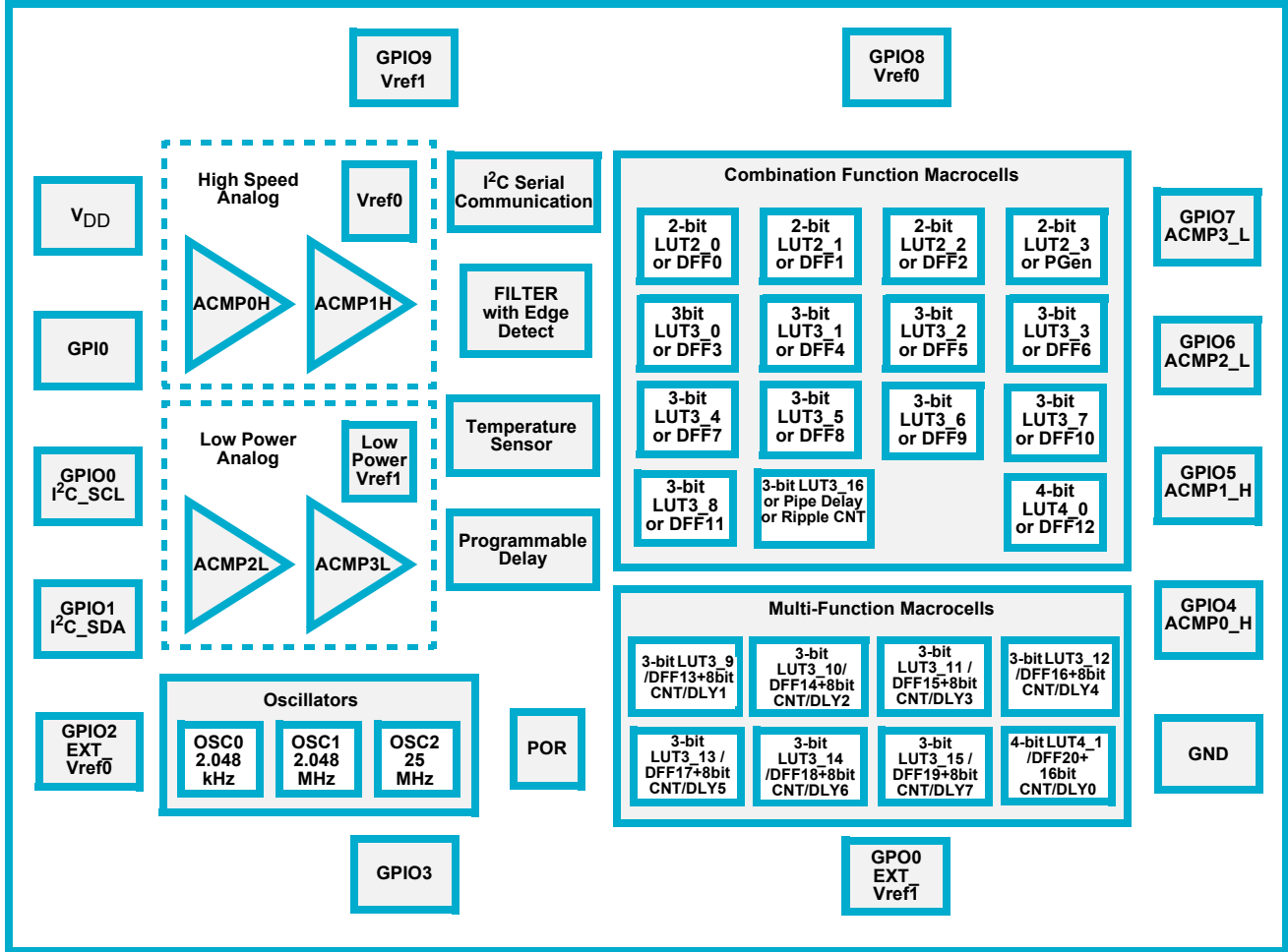

Figure 1: Block Diagram

# SLG46855-A

## Auto AEC-Q100 Qualified GreenPAK Programmable Mixed-Signal Matrix

### 2 Pinout

#### 2.1 PIN CONFIGURATION - FCQFN- 14L

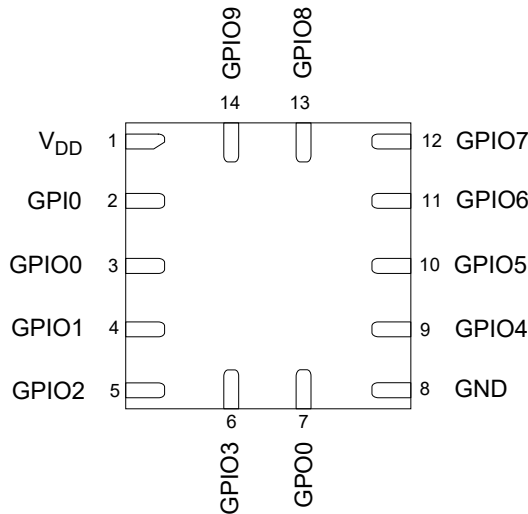

**FCQFN-14L  
(Top View)**

| Pin # | Pin Name        | Pin Functions                   |
|-------|-----------------|---------------------------------|
| 1     | V <sub>DD</sub> | Power Supply                    |
| 2     | GPIO0           | GPI, SLA_0                      |
| 3     | GPIO0           | GPIO, SCL                       |
| 4     | GPIO1           | GPIO, SDA                       |
| 5     | GPIO2           | GPIO with OE, EXT_Vref0, SLA_1  |
| 6     | GPIO3           | GPIO with OE                    |
| 7     | GPO0            | GPO, EXT_Vref1                  |
| 8     | GND             | Ground                          |
| 9     | GPIO4           | GPIO with OE, ACMP0_H+, SLA_2   |
| 10    | GPIO5           | GPIO with OE, ACMP1_H+, SLA_3   |
| 11    | GPIO6           | GPIO with OE, ACMP2_L+          |
| 12    | GPIO7           | GPIO with OE, ACMP3_L+          |
| 13    | GPIO8           | GPIO with OE, Vref0_OUT, TS_OUT |
| 14    | GPIO9           | GPIO with OE, Vref1_OUT         |

Legend:

- OE: Output Enable
- ACMPx+: ACMPx Positive Input
- ACMPx-: ACMPx Negative Input
- SCL: I<sup>2</sup>C Clock Input
- SDA: I<sup>2</sup>C Data Input/Output
- Vrefx: Voltage Reference Output
- EXT\_CLKx: External Clock Input
- SLA: Slave Address
- TS\_OUT: Temperature Output

**Table 1: Functional Pin Description**

| FCQFN 14L Pin # | Pin Name        | Signal Name     | Function                           | Input Options                         | Output Options |
|-----------------|-----------------|-----------------|------------------------------------|---------------------------------------|----------------|
| 1               | V <sub>DD</sub> | V <sub>DD</sub> | Power Supply                       | --                                    | --             |
|                 |                 | ACMP0_H+        | Analog Comparator 0 Positive Input | Analog                                | --             |
|                 |                 | ACMP1_H+        | Analog Comparator 1 Positive Input | Analog                                | --             |
|                 |                 | ACMP2_L+        | Analog Comparator 2 Positive Input | Analog                                | --             |
|                 |                 | ACMP3_L+        | Analog Comparator 3 Positive Input | Analog                                | --             |
| 2               | GPIO0           | GPIO0           | General Purpose Input              | Digital Input without Schmitt Trigger | --             |
|                 |                 |                 |                                    | Digital Input with Schmitt Trigger    | --             |
|                 |                 |                 |                                    | Low Voltage Digital Input             | --             |
|                 |                 | Slave Address 0 | --                                 | --                                    |                |



**Auto AEC-Q100 Qualified GreenPAK Programmable Mixed-Signal Matrix**
**Table 1: Functional Pin Description(Continued)**

| FCQFN<br>14L Pin # | Pin<br>Name | Signal<br>Name     | Function                                      | Input<br>Options                         | Output<br>Options                 |
|--------------------|-------------|--------------------|---|--|-----------------------------------|
| 3                  | GPIO0       | GPIO0              | General Purpose IO<br>with OE <b>(Note 1)</b> | Digital Input<br>without Schmitt Trigger | Open-Drain NMOS<br>(3.2x)         |
|                    |             |                    |   | Digital Input<br>with Schmitt Trigger    |                                   |
|                    |             |                    |   | Low Voltage Digital Input                | --                                |
|                    |             | SCL                | I <sup>2</sup> C Serial Clock                 | Digital Input<br>without Schmitt Trigger | --                                |
|                    |             |                    |   | Digital Input<br>with Schmitt Trigger    | --                                |
|                    |             |                    |   | Low Voltage Digital Input                | --                                |
| 4                  | GPIO1       | GPIO1              | General Purpose IO                            | Digital Input<br>without Schmitt Trigger | Open-Drain NMOS<br>(3.2x)         |
|                    |             |                    |   | Digital Input<br>with Schmitt Trigger    |                                   |
|                    |             |                    |   | Low Voltage Digital Input                |                                   |
|                    |             | SDA                | I <sup>2</sup> C Serial Data                  | Digital Input<br>without Schmitt Trigger | --                                |
|                    |             |                    |   | Digital Input<br>with Schmitt Trigger    | --                                |
|                    |             |                    |   | Low Voltage Digital Input                | --                                |
| 5                  | GPIO2       | GPIO2              | General Purpose IO<br>with OE <b>(Note 1)</b> | Digital Input<br>without Schmitt Trigger | Push-Pull (1x) (2x)               |
|                    |             |                    |   | Digital Input<br>with Schmitt Trigger    | Open-Drain NMOS<br>(1x) (2x)      |
|                    |             |                    |   | Low Voltage Digital Input                | --                                |
|                    |             | Slave<br>Address 1 |   | --                                       |                                   |
|                    |             | EXT_VREF0          | Analog Comparator<br>Negative Input           | Analog                                   | --                                |
| 6                  | GPIO3       | GPIO3              | General Purpose IO<br>with OE <b>(Note 1)</b> | Digital Input<br>without Schmitt Trigger | Push-Pull (1x) (2x)               |
|                    |             |                    |   | Digital Input<br>with Schmitt Trigger    | Open-Drain NMOS<br>(1x) (2x)      |
|                    |             |                    |   | Low Voltage Digital Input                | --                                |
| 7                  | GPO0        | GPO0               | General Purpose Output                        | --                                       | Push-Pull (1x) (2x)               |
|                    |             |                    |   | --                                       | Open-Drain NMOS<br>(1x) (2x) (4x) |
|                    |             | EXT_VREF1          | Analog Comparator<br>Negative Input           | Analog                                   | --                                |
| 8                  | GND         | GND                | Power Supply                                  | --                                       | --                                |

**Auto AEC-Q100 Qualified GreenPAK Programmable Mixed-Signal Matrix**
**Table 1: Functional Pin Description(Continued)**

| FCQFN<br>14L Pin # | Pin<br>Name        | Signal<br>Name | Function                                | Input<br>Options                         | Output<br>Options                 |
|--------------------|--------------------|----------------|---|--|-----------------------------------|
| 9                  | GPIO4              | GPIO4          | General Purpose IO<br>with OE (Note 1)  | Digital Input<br>without Schmitt Trigger | Push-Pull (1x) (2x)               |
|                    |                    |                |   | Digital Input<br>with Schmitt Trigger    | Open-Drain NMOS<br>(1x) (2x) (4x) |
|                    |                    |                |   | Low Voltage Digital Input                | --                                |
|                    |                    | ACMP0_H+       | Analog Comparator 0_H<br>Positive Input | Analog                                   | --                                |
|                    | Slave<br>Address 2 |                | --                                      | --                                       |                                   |
| 10                 | GPIO5              | GPIO5          | General Purpose IO<br>with OE (Note 1)  | Digital Input<br>without Schmitt Trigger | Push-Pull (1x) (2x)               |
|                    |                    |                |   | Digital Input<br>with Schmitt Trigger    | Open-Drain NMOS<br>(1x) (2x)      |
|                    |                    |                |   | Low Voltage Digital Input                | --                                |
|                    |                    | ACMP1_H+       | Analog Comparator 1_H<br>Positive Input | Analog                                   | --                                |
|                    | Slave<br>Address 3 |                | --                                      | --                                       |                                   |
| 11                 | GPIO6              | GPIO6          | General Purpose IO<br>with OE (Note 1)  | Digital Input<br>without Schmitt Trigger | Push-Pull (1x) (2x)               |
|                    |                    |                |   | Digital Input<br>with Schmitt Trigger    | Open-Drain NMOS<br>(1x) (2x)      |
|                    |                    |                |   | Low Voltage Digital Input                | --                                |
|                    |                    | ACMP2_L+       | Analog Comparator 2_L<br>Positive Input | Analog                                   | --                                |
| 12                 | GPIO7              | GPIO7          | General Purpose IO<br>with OE (Note 1)  | Digital Input<br>without Schmitt Trigger | Push-Pull (1x) (2x)               |
|                    |                    |                |   | Digital Input<br>with Schmitt Trigger    | Open-Drain NMOS<br>(1x) (2x)      |
|                    |                    |                |   | Low Voltage Digital Input                | --                                |
|                    |                    | ACMP3_L+       | Analog Comparator 3_L<br>Positive Input | Analog                                   | --                                |
| 13                 | GPIO8              | GPIO8          | General Purpose IO<br>with OE (Note 1)  | Digital Input<br>without Schmitt Trigger | Push-Pull (1x) (2x)               |
|                    |                    |                |   | Digital Input<br>with Schmitt Trigger    | Open-Drain NMOS<br>(1x) (2x)      |
|                    |                    |                |   | Low Voltage Digital Input                | --                                |
|                    |                    | Vref0          | Vref0 Output                            | Analog                                   | --                                |
| 14                 | GPIO9              | GPIO9          | General Purpose IO<br>with OE (Note 1)  | Digital Input<br>without Schmitt Trigger | Push-Pull (1x) (2x)               |
|                    |                    |                |   | Digital Input<br>with Schmitt Trigger    | Open-Drain NMOS<br>(1x) (2x)      |
|                    |                    |                |   | Low Voltage Digital Input                | --                                |
|                    |                    | Vref1          | Vref1 Output                            | Analog                                   | --                                |

**Note 1** General Purpose IO's with OE can be used to implement bidirectional signals under user control via Connection Matrix to OE signal in IO structure.

## SLG46855-A

### Auto AEC-Q100 Qualified GreenPAK Programmable Mixed-Signal Matrix

**Table 2: Pin Type Definitions**

| Pin Type        | Description                  |
|-----------------|------------------------------|
| V <sub>DD</sub> | Power Supply                 |
| GPI             | General Purpose Input        |
| GPIO            | General Purpose Input/Output |
| GPO             | General Purpose Output       |
| GND             | Ground                       |

# SLG46855-A

## Auto AEC-Q100 Qualified GreenPAK Programmable Mixed-Signal Matrix

### 3 Characteristics

#### 3.1 ABSOLUTE MAXIMUM RATINGS

Stresses beyond those listed under Absolute Maximum Ratings may cause permanent damage to the device. These are stress ratings only, so functional operation of the device at these or any other conditions beyond those indicated in the operational sections of the specification are not implied. Exposure to Absolute Maximum Rating conditions for extended periods may affect device reliability.

**Table 3: Absolute Maximum Ratings**

| Parameter   |              | Min         | Max              | Unit |
|---|--------------|-------------|------------------|------|
| Supply Voltage on $V_{DD}$ relative to GND                  |              | -0.3        | 7                | V    |
| DC Input Voltage  |              | GND - 0.5 V | $V_{DD} + 0.5$ V | V    |
| Maximum Average or DC Current (Through $V_{DD}$ or GND pin) |              | --          | 90               | mA   |
| Maximum Average or DC Current (Through pin)                 | Push-Pull 1x | --          | 11               | mA   |
|   | Push-Pull 2x | --          | 16               |      |
|   | Push-Pull 4x | --          | 32               |      |
|   | OD 1x        | --          | 11               |      |
|   | OD 2x        | --          | 21               |      |
|   | OD 4x        | --          | 43               |      |
| Current at Input Pin  |              | -1.0        | 1.0              | mA   |
| Input Leakage Current (Absolute Value)                      |              | --          | 1000             | nA   |
| Storage Temperature Range                                   |              | -65         | 150              | °C   |
| Junction Temperature  |              | --          | 150              | °C   |
| Moisture Sensitive Level                                    |              | 1           |                  |      |

#### 3.2 ELECTROSTATIC DISCHARGE RATINGS

**Table 4: Electrostatic Discharge Ratings**

| Parameter                             | Min  | Max | Unit |
|---------------------------------------|------|-----|------|
| ESD Protection (Human Body Model)     | 2000 | --  | V    |
| ESD Protection (Charged Device Model) | 1300 | --  | V    |

#### 3.3 RECOMMENDED OPERATING CONDITIONS

**Table 5: Recommended Operating Conditions**

| Parameter  | Condition                              | Min | Max            | Unit |
|--|--|-----|----------------|------|
| Supply Voltage ( $V_{DD}$ )                                |  | 2.3 | 5.5            | V    |
| Operating Ambient Temperature                              |  | -40 | 105            | °C   |
| Maximal Voltage Applied to any PIN in High Impedance State |  | --  | $V_{DD} + 0.3$ | V    |
| Capacitor Value at $V_{DD}$                                |  | 0.1 | --             | μF   |
| Analog Input Common Mode Range                             | Allowable Input Voltage at Analog Pins | 0   | $V_{DD}$       | V    |

# SLG46855-A

## Auto AEC-Q100 Qualified GreenPAK Programmable Mixed-Signal Matrix

### 3.4 ELECTRICAL CHARACTERISTICS

Table 6: EC at  $T_A = -40\text{ }^{\circ}\text{C}$  to  $+105\text{ }^{\circ}\text{C}$ ,  $V_{DD} = 2.3\text{ V}$  to  $5.5\text{ V}$  Unless Otherwise Noted

| Parameter | Description               | Condition   | Min                 | Typ | Max                 | Unit |
|-----------|---------------------------|---|---------------------|-----|---------------------|------|
| $V_{IH}$  | HIGH-Level Input Voltage  | Logic Input ( <b>Note 1</b> )   | $0.7 \times V_{DD}$ | --  | $V_{DD} + 0.3$      | V    |
|           |                           | Logic Input with Schmitt Trigger  | $0.8 \times V_{DD}$ | --  | $V_{DD} + 0.3$      | V    |
|           |                           | Low-Level Logic Input ( <b>Note 1</b> )   | 1.25                | --  | $V_{DD} + 0.3$      | V    |
| $V_{IL}$  | LOW-Level Input Voltage   | Logic Input ( <b>Note 1</b> )   | GND-0.3             | --  | $0.3 \times V_{DD}$ | V    |
|           |                           | Logic Input with Schmitt Trigger  | GND-0.3             | --  | $0.2 \times V_{DD}$ | V    |
|           |                           | Low-Level Logic Input ( <b>Note 1</b> )   | GND-0.3             | --  | 0.5                 | V    |
| $V_{OH}$  | HIGH-Level Output Voltage | Push-Pull, 1x Drive, $V_{DD} = 2.3\text{ V}$ , $I_{OH} = 1\text{ mA}$                           | 2.17                | --  | --                  | V    |
|           |                           | Push-Pull, 1x Drive, $V_{DD} = 3.3\text{ V}$ , $I_{OH} = 3\text{ mA}$                           | 3.02                | --  | --                  | V    |
|           |                           | Push-Pull, 1x Drive, $V_{DD} = 5.5\text{ V}$ , $I_{OH} = 5\text{ mA}$                           | 5.19                | --  | --                  | V    |
|           |                           | Push-Pull, 2x Drive, $V_{DD} = 2.3\text{ V}$ , $I_{OH} = 1\text{ mA}$                           | 2.23                | --  | --                  | V    |
|           |                           | Push-Pull, 2x Drive, $V_{DD} = 3.3\text{ V}$ , $I_{OH} = 3\text{ mA}$                           | 3.16                | --  | --                  | V    |
|           |                           | Push-Pull, 2x Drive, $V_{DD} = 5.5\text{ V}$ , $I_{OH} = 5\text{ mA}$                           | 5.34                | --  | --                  | V    |
|           |                           | Push-Pull, 4x Drive (only for GPO0 and GPIO4), $V_{DD} = 2.3\text{ V}$ , $I_{OH} = 1\text{ mA}$ | 2.27                | --  | --                  | V    |
|           |                           | Push-Pull, 4x Drive (only for GPO0 and GPIO4), $V_{DD} = 3.3\text{ V}$ , $I_{OH} = 3\text{ mA}$ | 3.23                | --  | --                  | V    |
|           |                           | Push-Pull, 4x Drive (only for GPO0 and GPIO4), $V_{DD} = 5.5\text{ V}$ , $I_{OH} = 5\text{ mA}$ | 5.41                | --  | --                  | V    |
| $V_{OL}$  | LOW-Level Output Voltage  | Push-Pull, 1x Drive, $V_{DD} = 2.3\text{ V}$ , $I_{OL} = 1\text{ mA}$                           | --                  | --  | 0.100               | V    |
|           |                           | Push-Pull, 1x Drive, $V_{DD} = 3.3\text{ V}$ , $I_{OL} = 3\text{ mA}$                           | --                  | --  | 0.227               | V    |
|           |                           | Push-Pull, 1x Drive, $V_{DD} = 5.5\text{ V}$ , $I_{OL} = 5\text{ mA}$                           | --                  | --  | 0.272               | V    |
|           |                           | Push-Pull, 2x Drive, $V_{DD} = 2.3\text{ V}$ , $I_{OL} = 1\text{ mA}$                           | --                  | --  | 0.049               | V    |
|           |                           | Push-Pull, 2x Drive, $V_{DD} = 3.3\text{ V}$ , $I_{OL} = 3\text{ mA}$                           | --                  | --  | 0.112               | V    |

**Auto AEC-Q100 Qualified GreenPAK Programmable Mixed-Signal Matrix**
**Table 6: EC at  $T_A = -40\text{ }^\circ\text{C}$  to  $+105\text{ }^\circ\text{C}$ ,  $V_{DD} = 2.3\text{ V}$  to  $5.5\text{ V}$  Unless Otherwise Noted (Continued)**

| Parameter   | Description              | Condition   | Min                                      | Typ  | Max   | Unit |
|---|--------------------------|---|--|--|-------|------|
| $V_{OL}$  | LOW-Level Output Voltage | Push-Pull, 2x Drive,<br>$V_{DD} = 5.5\text{ V}$ , $I_{OL} = 5\text{ mA}$                              | --                                       | --   | 0.137 | V    |
|   |                          | Push-Pull, 4x Drive<br>(only for GPO0 and GPIO4),<br>$V_{DD} = 2.3\text{ V}$ , $I_{OL} = 1\text{ mA}$ | --                                       | --   | 0.023 | V    |
|   |                          | Push-Pull, 4x Drive<br>(only for GPO0 and GPIO4),<br>$V_{DD} = 3.3\text{ V}$ , $I_{OL} = 3\text{ mA}$ | --                                       | --   | 0.055 | V    |
|   |                          | Push-Pull, 4x Drive<br>(only for GPO0 and GPIO4),<br>$V_{DD} = 5.5\text{ V}$ , $I_{OL} = 5\text{ mA}$ | --                                       | --   | 0.067 | V    |
|   |                          | NMOS OD, 1x Drive,<br>$V_{DD} = 2.3\text{ V}$ , $I_{OL} = 1\text{ mA}$                                | --                                       | --   | 0.042 | V    |
|   |                          | NMOS OD, 1x Drive,<br>$V_{DD} = 3.3\text{ V}$ , $I_{OL} = 3\text{ mA}$                                | --                                       | --   | 0.093 | V    |
|   |                          | NMOS OD, 1x Drive,<br>$V_{DD} = 5.5\text{ V}$ , $I_{OL} = 5\text{ mA}$                                | --                                       | --   | 0.117 | V    |
|   |                          | NMOS OD, 2x Drive,<br>$V_{DD} = 2.3\text{ V}$ , $I_{OL} = 1\text{ mA}$                                | --                                       | --   | 0.020 | V    |
|   |                          | NMOS OD, 2x Drive,<br>$V_{DD} = 3.3\text{ V}$ , $I_{OL} = 3\text{ mA}$                                | --                                       | --   | 0.047 | V    |
|   |                          | NMOS OD, 2x Drive,<br>$V_{DD} = 5.5\text{ V}$ , $I_{OL} = 5\text{ mA}$                                | --                                       | --   | 0.058 | V    |
|   |                          | NMOS OD, 4x Drive<br>(only for GPO0 and GPIO4),<br>$V_{DD} = 2.3\text{ V}$ , $I_{OL} = 1\text{ mA}$   | --                                       | --   | 0.009 | V    |
|   |                          | NMOS OD, 4x Drive<br>(only for GPO0 and GPIO4),<br>$V_{DD} = 3.3\text{ V}$ , $I_{OL} = 3\text{ mA}$   | --                                       | --   | 0.022 | V    |
|   |                          | NMOS OD, 4x Drive<br>(only for GPO0 and GPIO4),<br>$V_{DD} = 5.5\text{ V}$ , $I_{OL} = 5\text{ mA}$   | --                                       | --   | 0.027 | V    |
|   |                          | $I_{OH}$  | HIGH-Level Output Pulse Current (Note 2) | Push-Pull, 1x Drive,<br>$V_{DD} = 2.3\text{ V}$ , $V_{OH} = V_{DD} - 0.2\text{ V}$ | 1.44  | --   |
| Push-Pull, 1x Drive,<br>$V_{DD} = 3.3\text{ V}$ , $V_{OH} = 2.4\text{ V}$                                       | 7.75                     |   |  | --   | --    | mA   |
| Push-Pull, 1x Drive,<br>$V_{DD} = 5.5\text{ V}$ , $V_{OH} = 2.75\text{ V}$                                      | 26.98                    |   |  | --   | --    | mA   |
| Push-Pull, 2x Drive,<br>$V_{DD} = 2.3\text{ V}$ , $V_{OH} = V_{DD} - 0.2\text{ V}$                              | 2.82                     |   |  | --   | --    | mA   |
| Push-Pull, 2x Drive,<br>$V_{DD} = 3.3\text{ V}$ , $V_{OH} = 2.4\text{ V}$                                       | 15.12                    |   |  | --   | --    | mA   |
| Push-Pull, 2x Drive,<br>$V_{DD} = 5.5\text{ V}$ , $V_{OH} = 2.75\text{ V}$                                      | 51.97                    |   |  | --   | --    | mA   |
| Push-Pull, 4x Drive<br>(only for GPO0 and GPIO4),<br>$V_{DD} = 2.3\text{ V}$ , $V_{OH} = V_{DD} - 0.2\text{ V}$ | 5.47                     |   |  | --   | --    | mA   |
| Push-Pull, 4x Drive<br>(only for GPO0 and GPIO4),<br>$V_{DD} = 3.3\text{ V}$ , $V_{OH} = 2.4\text{ V}$          | 28.97                    |   |  | --   | --    | mA   |

**Auto AEC-Q100 Qualified GreenPAK Programmable Mixed-Signal Matrix**
**Table 6: EC at  $T_A = -40\text{ }^\circ\text{C}$  to  $+105\text{ }^\circ\text{C}$ ,  $V_{DD} = 2.3\text{ V}$  to  $5.5\text{ V}$  Unless Otherwise Noted (Continued)**

| Parameter   | Description                              | Condition   | Min   | Typ  | Max  | Unit |
|-------------|--|---|-------|------|------|------|
| $I_{OH}$    | HIGH-Level Output Pulse Current (Note 2) | Push-Pull, 4x Drive (only for GPO0 and GPIO4), $V_{DD} = 5.5\text{ V}$ , $V_{OH} = 2.75\text{ V}$ | 97.85 | --   | --   | mA   |
| $I_{OL}$    | LOW-Level Output Pulse Current (Note 2)  | Push-Pull, 1x Drive, $V_{DD} = 2.3\text{ V}$ , $V_{OL} = 0.2\text{ V}$                            | 1.92  | --   | --   | mA   |
|             |  | Push-Pull, 1x Drive, $V_{DD} = 3.3\text{ V}$ , $V_{OL} = 0.4\text{ V}$                            | 5.01  | --   | --   | mA   |
|             |  | Push-Pull, 1x Drive, $V_{DD} = 5.5\text{ V}$ , $V_{OL} = 0.4\text{ V}$                            | 7.10  | --   | --   | mA   |
|             |  | Push-Pull, 2x Drive, $V_{DD} = 2.3\text{ V}$ , $V_{OL} = 0.2\text{ V}$                            | 3.84  | --   | --   | mA   |
|             |  | Push-Pull, 2x Drive, $V_{DD} = 3.3\text{ V}$ , $V_{OL} = 0.4\text{ V}$                            | 9.96  | --   | --   | mA   |
|             |  | Push-Pull, 2x Drive, $V_{DD} = 5.5\text{ V}$ , $V_{OL} = 0.4\text{ V}$                            | 13.96 | --   | --   | mA   |
|             |  | Push-Pull, 4x Drive (only for GPO0 and GPIO4), $V_{DD} = 2.3\text{ V}$ , $V_{OL} = 0.2\text{ V}$  | 7.72  | --   | --   | mA   |
|             |  | Push-Pull, 4x Drive (only for GPO0 and GPIO4), $V_{DD} = 3.3\text{ V}$ , $V_{OL} = 0.4\text{ V}$  | 20.12 | --   | --   | mA   |
|             |  | Push-Pull, 4x Drive (only for GPO0 and GPIO4), $V_{DD} = 5.5\text{ V}$ , $V_{OL} = 0.4\text{ V}$  | 28.34 | --   | --   | mA   |
|             |  | NMOS OD, 1x Drive, $V_{DD} = 2.3\text{ V}$ , $V_{OL} = 0.2\text{ V}$                              | 4.71  | --   | --   | mA   |
|             |  | NMOS OD, 1x Drive, $V_{DD} = 3.3\text{ V}$ , $V_{OL} = 0.4\text{ V}$                              | 12.21 | --   | --   | mA   |
|             |  | NMOS OD, 1x Drive, $V_{DD} = 5.5\text{ V}$ , $V_{OL} = 0.4\text{ V}$                              | 16.95 | --   | --   | mA   |
|             |  | NMOS OD, 2x Drive, $V_{DD} = 2.3\text{ V}$ , $V_{OL} = 0.2\text{ V}$                              | 9.24  | --   | --   | mA   |
|             |  | NMOS OD, 2x Drive, $V_{DD} = 3.3\text{ V}$ , $V_{OL} = 0.4\text{ V}$                              | 23.68 | --   | --   | mA   |
|             |  | NMOS OD, 2x Drive, $V_{DD} = 5.5\text{ V}$ , $V_{OL} = 0.4\text{ V}$                              | 32.64 | --   | --   | mA   |
|             |  | NMOS OD, 4x Drive (only for GPO0 and GPIO4), $V_{DD} = 2.3\text{ V}$ , $V_{OL} = 0.2\text{ V}$    | 18.96 | --   | --   | mA   |
|             |  | NMOS OD, 4x Drive (only for GPO0 and GPIO4), $V_{DD} = 3.3\text{ V}$ , $V_{OL} = 0.4\text{ V}$    | 49.08 | --   | --   | mA   |
|             |  | NMOS OD, 4x Drive (only for GPO0 and GPIO4), $V_{DD} = 5.5\text{ V}$ , $V_{OL} = 0.4\text{ V}$    | 68.27 | --   | --   | mA   |
| $T_{SU}$    | Startup Time                             | From $V_{DD}$ rising past $PON_{THR}$ , $T_{RAMP} = 10\text{ ms}$                                 | --    | 1.4  | 2.1  | ms   |
| $PON_{THR}$ | Power-On Threshold                       | $V_{DD}$ Level Required to Start Up the Chip  | 1.56  | 1.84 | 2.03 | V    |

**Auto AEC-Q100 Qualified GreenPAK Programmable Mixed-Signal Matrix**
**Table 6: EC at  $T_A = -40\text{ }^\circ\text{C}$  to  $+105\text{ }^\circ\text{C}$ ,  $V_{DD} = 2.3\text{ V}$  to  $5.5\text{ V}$  Unless Otherwise Noted (Continued)**

| Parameter           | Description  | Condition  | Min  | Typ  | Max  | Unit       |
|---------------------|--|--|------|------|------|------------|
| POFF <sub>THR</sub> | Power-Off Threshold                                    | $V_{DD}$ Level Required to Switch Off the Chip         | 0.83 | 1.16 | 1.63 | V          |
| R <sub>PULL</sub>   | Pull-up or Pull-down Resistance                        | 1 M for Pull-up: $V_{IN} = \text{GND}$                 | --   | 1    | --   | M $\Omega$ |
|                     |  | 1 M for Pull-down: $V_{IN} = V_{DD}$                   | --   | 1    | --   | M $\Omega$ |
|                     |  | 100 k for Pull-up: $V_{IN} = \text{GND}$               | --   | 100  | --   | k $\Omega$ |
|                     |  | 100 k for Pull-down: $V_{IN} = V_{DD}$                 | --   | 100  | --   | k $\Omega$ |
|                     |  | 10 k For Pull-up: $V_{IN} = \text{GND}$                | --   | 10   | --   | k $\Omega$ |
|                     |  | 10 k for Pull-down: $V_{IN} = V_{DD}$                  | --   | 10   | --   | k $\Omega$ |
| C <sub>IN</sub>     | Input Capacitance                                      |  |      | 4    |      | pF         |
| I <sub>LKG</sub>    | Logic Input without Schmitt Trigger (Floating) Leakage | $V_{in} = V_{DD}$ , $V_{DD} = 2.3\text{ V}$ , All Pins | --   | 4.61 | --   | nA         |
|                     |  | $V_{in} = V_{DD}$ , $V_{DD} = 3.3\text{ V}$ , All Pins | --   | 5.00 | --   | nA         |
|                     |  | $V_{in} = V_{DD}$ , $V_{DD} = 5.5\text{ V}$ , All Pins | --   | 6.56 | --   | nA         |
|                     |  | $V_{in} = 0$ , $V_{DD} = 2.3\text{ V}$ , All Pins      | --   | 1.41 | --   | nA         |
|                     |  | $V_{in} = 0$ , $V_{DD} = 3.3\text{ V}$ , All Pins      | --   | 1.58 | --   | nA         |
|                     |  | $V_{in} = 0$ , $V_{DD} = 5.5\text{ V}$ , All Pins      | --   | 4.44 | --   | nA         |
|                     | Logic Input with Schmitt Trigger (Floating) Leakage    | $V_{in} = V_{DD}$ , $V_{DD} = 2.3\text{ V}$ , All Pins | --   | 4.72 | --   | nA         |
|                     |  | $V_{in} = V_{DD}$ , $V_{DD} = 3.3\text{ V}$ , All Pins | --   | 5.10 | --   | nA         |
|                     |  | $V_{in} = V_{DD}$ , $V_{DD} = 5.5\text{ V}$ , All Pins | --   | 6.64 | --   | nA         |
|                     |  | $V_{in} = 0$ , $V_{DD} = 2.3\text{ V}$ , All Pins      | --   | 1.46 | --   | nA         |
|                     |  | $V_{in} = 0$ , $V_{DD} = 3.3\text{ V}$ , All Pins      | --   | 1.62 | --   | nA         |
|                     |  | $V_{in} = 0$ , $V_{DD} = 5.5\text{ V}$ , All Pins      | --   | 4.48 | --   | nA         |
|                     | Low-Level Logic Input (Floating) Leakage               | $V_{in} = V_{DD}$ , $V_{DD} = 2.3\text{ V}$ , All Pins | --   | 4.64 | --   | nA         |
|                     |  | $V_{in} = V_{DD}$ , $V_{DD} = 3.3\text{ V}$ , All Pins | --   | 5.01 | --   | nA         |
|                     |  | $V_{in} = V_{DD}$ , $V_{DD} = 5.5\text{ V}$ , All Pins | --   | 6.52 | --   | nA         |
|                     |  | $V_{in} = 0$ , $V_{DD} = 2.3\text{ V}$ , All Pins      | --   | 1.43 | --   | nA         |
|                     |  | $V_{in} = 0$ , $V_{DD} = 3.3\text{ V}$ , All Pins      | --   | 1.59 | --   | nA         |
|                     |  | $V_{in} = 0$ , $V_{DD} = 5.5\text{ V}$ , All Pins      | --   | 4.43 | --   | nA         |

**Note 1** No hysteresis.

**Note 2** DC or average current through any pin should not exceed value given in Absolute Maximum Conditions.

**3.5 I<sup>2</sup>C PINS ELECTRICAL CHARACTERISTICS**
**Table 7: EC of the I<sup>2</sup>C Pins for DI Mode at  $T_A = -40\text{ }^\circ\text{C}$  to  $+105\text{ }^\circ\text{C}$ ,  $V_{DD} = 2.3\text{ V}$  to  $5.5\text{ V}$  Unless Otherwise Noted**

| Parameter        | Description                          | Condition | Fast-Mode            |                     | Fast-Mode Plus       |                     | Unit |
|------------------|--------------------------------------|-----------|----------------------|---------------------|----------------------|---------------------|------|
|                  |                                      |           | Min                  | Max                 | Min                  | Max                 |      |
| V <sub>IL</sub>  | LOW-level Input Voltage              |           | -0.5                 | 0.3xV <sub>DD</sub> | -0.5                 | 0.3xV <sub>DD</sub> | V    |
| V <sub>IH</sub>  | HIGH-level Input Voltage             |           | 0.7xV <sub>DD</sub>  | 5.5                 | 0.7xV <sub>DD</sub>  | 5.5                 | V    |
| V <sub>HYS</sub> | Hysteresis of Schmitt Trigger Inputs |           | 0.05xV <sub>DD</sub> | --                  | 0.05xV <sub>DD</sub> | --                  | V    |



# SLG46855-A

## Auto AEC-Q100 Qualified GreenPAK Programmable Mixed-Signal Matrix

**Table 7: EC of the I<sup>2</sup>C Pins for DI Mode at T<sub>A</sub> = -40 °C to +105 °C, V<sub>DD</sub> = 2.3 V to 5.5 V Unless Otherwise Noted(Continued)**

| Parameter        | Description   | Condition  | Fast-Mode                      |                     | Fast-Mode Plus                 |                     | Unit |
|------------------|---|--|--------------------------------|---------------------|--------------------------------|---------------------|------|
|                  |   |  | Min                            | Max                 | Min                            | Max                 |      |
| V <sub>OL1</sub> | LOW-Level Output Voltage 1  | (Open-Drain or open collector) at 3 mA sink current<br>V <sub>DD</sub> > 2 V | 0                              | 0.4                 | 0                              | 0.4                 | V    |
| V <sub>OL2</sub> | LOW-Level Output Voltage 2  | (Open-Drain or open collector) at 2 mA sink current<br>V <sub>DD</sub> ≤ 2 V | 0                              | 0.2xV <sub>DD</sub> | 0                              | 0.2xV <sub>DD</sub> | V    |
| t <sub>of</sub>  | Output Fall Time from V <sub>IHmin</sub> to V <sub>ILmax</sub> (Note 1) |  | 14x<br>(V <sub>DD</sub> /5.5V) | 250                 | 10x<br>(V <sub>DD</sub> /5.5V) | 120                 | ns   |
| I <sub>i</sub>   | Input Current each IO Pin   | 0.1xV <sub>DD</sub> < V <sub>I</sub> < 0.9xV <sub>DDmax</sub>                | -10                            | +10                 | -10                            | +10                 | μA   |
| C <sub>i</sub>   | Capacitance for each IO Pin   |  | --                             | 10                  | --                             | 10                  | pF   |

**Note 1** Does not meet standard I<sup>2</sup>C specifications: t<sub>of</sub> = 20x(V<sub>DD</sub>/5.5V) (min).  
**Note 2** For Fast-mode Plus SDA pin must be configured as NMOS 3.2x Open-Drain, see register [796] in section 17.

**Table 8: EC of the I<sup>2</sup>C Pins for DILV Mode at T<sub>A</sub> = -40 °C to +105 °C, V<sub>DD</sub> = 2.3 V to 5.5 V Unless Otherwise Noted**

| Parameter        | Description   | Condition  | Fast-Mode                      |                      | Unit |
|------------------|---|--|--------------------------------|----------------------|------|
|                  |   |  | Min                            | Max                  |      |
| V <sub>IL</sub>  | LOW-level Input Voltage (Note 1)  |  | GND-0.3                        | 0.5                  | V    |
| V <sub>IH</sub>  | HIGH-level Input Voltage (Note 1)                                       |  | 1.25                           | V <sub>DD</sub> +0.3 | V    |
| V <sub>HYS</sub> | Hysteresis of Schmitt Trigger Inputs                                    |  | 0.05xV <sub>DD</sub>           | --                   | V    |
| V <sub>OL1</sub> | LOW-Level Output Voltage 1  | (Open-Drain or open collector) at 3mA sink current<br>V <sub>DD</sub> > 2 V  | 0                              | 0.4                  | V    |
| V <sub>OL2</sub> | LOW-Level Output Voltage 2  | (Open-Drain or open collector) at 2 mA sink current<br>V <sub>DD</sub> ≤ 2 V | 0                              | 0.2xV <sub>DD</sub>  | V    |
| t <sub>of</sub>  | Output Fall Time from V <sub>IHmin</sub> to V <sub>ILmax</sub> (Note 1) |  | 14x<br>(V <sub>DD</sub> /5.5V) | 250                  | ns   |
| I <sub>i</sub>   | Input Current each IO Pin   | 0.1xV <sub>DD</sub> < V <sub>I</sub> < 0.9xV <sub>DDmax</sub>                | -10                            | +10                  | μA   |
| C <sub>i</sub>   | Capacitance for each IO Pin   |  | --                             | 10                   | pF   |

**Note 1** Does not meet standard I<sup>2</sup>C specifications: V<sub>IL</sub> = -0.5 V (min), V<sub>IL</sub> = 0.3xV<sub>DD</sub> (max), V<sub>IH</sub> = 0.7xV<sub>DD</sub> (min), V<sub>IH</sub> = 5.5 V (max), t<sub>of</sub> = 20x(V<sub>DD</sub>/5.5V) (min).

**Table 9: I<sup>2</sup>C Pins Timing Characteristics, DI Mode, T<sub>A</sub> = -40 °C to +105 °C, V<sub>DD</sub> = 2.3 V to 5.5 V Unless Otherwise Noted**

| Parameter        | Description           | Condition | Speed   |     |     |       |     |      | Unit |
|------------------|-----------------------|-----------|---------|-----|-----|-------|-----|------|------|
|                  |                       |           | 400 kHz |     |     | 1 MHz |     |      |      |
|                  |                       |           | Min     | Typ | Max | Min   | Typ | Max  |      |
| F <sub>SCL</sub> | Clock Frequency, SCL  |           | --      | --  | 400 | --    | --  | 1000 | kHz  |
| t <sub>LOW</sub> | Clock Pulse Width Low |           | 1300    | --  | --  | 500   | --  | --   | ns   |

# SLG46855-A

## Auto AEC-Q100 Qualified GreenPAK Programmable Mixed-Signal Matrix

**Table 9: I<sup>2</sup>C Pins Timing Characteristics, DI Mode, T<sub>A</sub> = -40 °C to +105 °C, V<sub>DD</sub> = 2.3 V to 5.5 V Unless Otherwise Noted**

| Parameter           | Description  | Condition               | Speed   |     |     |       |     |     | Unit |
|---------------------|--|-------------------------|---------|-----|-----|-------|-----|-----|------|
|                     |  |                         | 400 kHz |     |     | 1 MHz |     |     |      |
|                     |  |                         | Min     | Typ | Max | Min   | Typ | Max |      |
| t <sub>HIGH</sub>   | Clock Pulse Width High                             |                         | 600     | --  | --  | 260   | --  | --  | ns   |
| t <sub>I</sub>      | Input Filter Spike Suppression (SCL, SDA) (Note 1) | V <sub>DD</sub> = 2.3 V | --      | --  | 90  | --    | --  | 87  | ns   |
|                     |  | V <sub>DD</sub> = 3.3 V | --      | --  | 90  | --    | --  | 87  |      |
|                     |  | V <sub>DD</sub> = 5.5 V | --      | --  | 90  | --    | --  | 87  |      |
| t <sub>VD;ACK</sub> | Data Valid Acknowledge Time                        |                         | --      | --  | 900 | --    | --  | 450 | ns   |
| t <sub>BUF</sub>    | Bus Free Time between Stop and Start               |                         | 1300    | --  | --  | 500   | --  | --  | ns   |
| t <sub>HD_STA</sub> | Start Hold Time                                    |                         | 600     | --  | --  | 260   | --  | --  | ns   |
| t <sub>SU_STA</sub> | Start Set-up Time                                  |                         | 600     | --  | --  | 260   | --  | --  | ns   |
| t <sub>HD_DAT</sub> | Data Hold Time                                     | Rising Edge             | 0       | --  | --  | 0     | --  | --  | ns   |
|                     |  | Falling Edge            | 0       | --  | --  | 0     | --  | --  | ns   |
| t <sub>SU_DAT</sub> | Data Set-up Time                                   |                         | 100     | --  | --  | 50    | --  | --  | ns   |
| t <sub>R</sub>      | Inputs Rise Time                                   | C = 15 pF               | --      | --  | 300 | --    | --  | 120 | ns   |
|                     |  | C = 100 pF              | --      | --  | 300 | --    | --  | 120 | ns   |
|                     |  | C = 400 pF              | --      | --  | 300 | --    | --  | 120 | ns   |
| t <sub>F</sub>      | Inputs Fall Time                                   | C = 15 pF               | --      | --  | 300 | --    | --  | 120 | ns   |
|                     |  | C = 100 pF              | --      | --  | 300 | --    | --  | 120 | ns   |
|                     |  | C = 400 pF              | --      | --  | 300 | --    | --  | 120 | ns   |
| t <sub>SU_STO</sub> | Stop Set-up Time                                   |                         | 600     | --  | --  | 260   | --  | --  | ns   |
| t <sub>VD;DAT</sub> | Data Valid Time                                    |                         | 50      | --  | --  | 50    | --  | --  | ns   |

**Note 1** Does not meet standard I<sup>2</sup>C specifications: t<sub>I</sub> = 95 ns for V<sub>DD</sub> = 2.3 V, t<sub>I</sub> = 95 ns for V<sub>DD</sub> = 3.3 V, t<sub>I</sub> = 111 ns for V<sub>DD</sub> = 5.5V for 400 kHz; t<sub>I</sub> = 168 ns for V<sub>DD</sub> = 2.3 V, t<sub>I</sub> = 157 ns for V<sub>DD</sub> = 3.3 V, t<sub>I</sub> = 156 ns for V<sub>DD</sub> = 5.5 V for 1 MHz.

**Note 2** Timing diagram can be found in the [Figure 100](#).

**Note 3** Please follow official I<sup>2</sup>C spec UM10204.

**Table 10: I<sup>2</sup>C Pins Timing Characteristics, DILV Mode, T<sub>A</sub> = -40°C to +105°C, V<sub>DD</sub> = 2.3V to 5.5V Unless Otherwise Noted**

| Parameter           | Description  | Condition               | Speed   |     |     | Unit |
|---------------------|--|-------------------------|---------|-----|-----|------|
|                     |  |                         | 400 kHz |     |     |      |
|                     |  |                         | Min     | Typ | Max |      |
| F <sub>SCL</sub>    | Clock Frequency, SCL                               |                         | --      | --  | 400 | kHz  |
| t <sub>LOW</sub>    | Clock Pulse Width Low                              |                         | 1300    | --  | --  | ns   |
| t <sub>HIGH</sub>   | Clock Pulse Width High                             |                         | 600     | --  | --  | ns   |
| t <sub>I</sub>      | Input Filter Spike Suppression (SCL, SDA) (Note 1) | V <sub>DD</sub> = 2.3 V | --      | --  | 300 | ns   |
|                     |  | V <sub>DD</sub> = 3.3 V | --      | --  | 235 |      |
|                     |  | V <sub>DD</sub> = 5.5 V | --      | --  | 185 |      |
| t <sub>AA</sub>     | Clock Low to Data Out Valid                        |                         | --      | --  | 900 | ns   |
| t <sub>BUF</sub>    | Bus Free Time between Stop and Start               |                         | 1300    | --  | --  | ns   |
| t <sub>HD_STA</sub> | Start Hold Time                                    |                         | 600     | --  | --  | ns   |

**Auto AEC-Q100 Qualified GreenPAK Programmable Mixed-Signal Matrix**
**Table 10: I<sup>2</sup>C Pins Timing Characteristics, DILV Mode, T<sub>A</sub> = -40°C to +105°C, V<sub>DD</sub> = 2.3V to 5.5V Unless Otherwise Noted**

| Parameter           | Description                      | Condition    | Speed   |     |     | Unit |
|---------------------|----------------------------------|--------------|---------|-----|-----|------|
|                     |                                  |              | 400 kHz |     |     |      |
|                     |                                  |              | Min     | Typ | Max |      |
| t <sub>SU_STA</sub> | Start Set-up Time                |              | 600     | --  | --  | ns   |
| t <sub>HD_DAT</sub> | Data Hold Time ( <b>Note 1</b> ) | Rising Edge  | 255     | --  | --  | ns   |
|                     |                                  | Falling Edge | 0       | --  | --  | ns   |
| t <sub>SU_DAT</sub> | Data Set-up Time                 |              | 100     | --  | --  | ns   |
| t <sub>R</sub>      | Inputs Rise Time                 | C = 15 pF    | --      | --  | 300 | ns   |
|                     |                                  | C = 100 pF   | --      | --  | 300 | ns   |
|                     |                                  | C = 400pF    | --      | --  | 300 | ns   |
| t <sub>F</sub>      | Inputs Fall Time                 | C = 15 pF    | --      | --  | 300 | ns   |
|                     |                                  | C = 100 pF   | --      | --  | 300 | ns   |
|                     |                                  | C = 400 pF   | --      | --  | 300 | ns   |
| t <sub>SU_STO</sub> | Stop Set-up Time                 |              | 600     | --  | --  | ns   |
| t <sub>DH</sub>     | Data Out Hold Time               |              | 50      | --  | --  | ns   |

**Note 1** Does not meet standard I<sup>2</sup>C specifications: t<sub>i</sub> = 95 ns for V<sub>DD</sub> = 2.3 V, t<sub>i</sub> = 95 ns for V<sub>DD</sub> = 3.3 V, t<sub>i</sub> = 111 ns for V<sub>DD</sub> = 5.5 V; t<sub>HD\_DAT</sub> = 0 ns (min) for Rising Edge.

**Note 2** Timing diagram can be found in the [Figure 100](#).

**Note 3** Please follow official I<sup>2</sup>C spec UM10204.

**Note 4** When SCL Input is in Low-Level Logic mode max frequency is 400 kHz.

# SLG46855-A

## Auto AEC-Q100 Qualified GreenPAK Programmable Mixed-Signal Matrix

### 3.6 MACROCELLS CURRENT CONSUMPTION

Table 11: Typical Current Estimated for Each Macrocell at  $T_A = 25\text{ }^\circ\text{C}$

| Parameter   | Description | Note  | $V_{DD} = 2.5\text{ V}$ | $V_{DD} = 3.3\text{ V}$ | $V_{DD} = 5.0\text{ V}$ | Unit          |
|---|-------------|---|-------------------------|-------------------------|-------------------------|---------------|
| $I_{DD}$  | Current     | Chip Quiescent  | 0.34                    | 0.39                    | 0.46                    | $\mu\text{A}$ |
|   |             | Vref0, SourceNone   | 7.61                    | 7.67                    | 7.88                    | $\mu\text{A}$ |
|   |             | Vref1, SourceNone   | 1.39                    | 1.42                    | 1.51                    | $\mu\text{A}$ |
|   |             | OSC2 25 MHz, pre-divider = 1, second divider = 1  | 50.46                   | 62.63                   | 90.60                   | $\mu\text{A}$ |
|   |             | OSC2 25 MHz, pre-divider = 4, second divider = 1  | 33.46                   | 39.91                   | 55.47                   | $\mu\text{A}$ |
|   |             | OSC2 25 MHz, pre-divider = 8, second divider = 1  | 30.35                   | 35.75                   | 49.03                   | $\mu\text{A}$ |
|   |             | OSC1 2.048 MHz, pre-divider = 1, second divider = 1                                     | 20.64                   | 21.99                   | 24.94                   | $\mu\text{A}$ |
|   |             | OSC1 2.048 MHz, pre-divider = 4, second divider = 1                                     | 18.56                   | 19.21                   | 20.61                   | $\mu\text{A}$ |
|   |             | OSC1 2.048 MHz, pre-divider = 8, second divider = 1                                     | 18.18                   | 18.71                   | 19.84                   | $\mu\text{A}$ |
|   |             | OSC0 2.048 kHz, pre-divider = 1, second divider = 1                                     | 0.62                    | 0.66                    | 0.77                    | $\mu\text{A}$ |
|   |             | OSC0 2.048 kHz, pre-divider = 4, second divider = 1                                     | 0.62                    | 0.66                    | 0.76                    | $\mu\text{A}$ |
|   |             | OSC0 2.048 kHz, pre-divider = 8, second divider = 1                                     | 0.61                    | 0.66                    | 0.76                    | $\mu\text{A}$ |
|   |             | Temperature Sensor, output range 1 (0.62 V to 0.99 V)                                   | 14.80                   | 14.87                   | 15.43                   | $\mu\text{A}$ |
|   |             | Temperature Sensor, output range 2 (0.75 V to 1.2 V)                                    | 14.94                   | 15.02                   | 15.43                   | $\mu\text{A}$ |
|   |             | All ACMPs (includes internal Vref, $V_{in+} = 0$ , Vref = 32 mV)                        | 37.36                   | 38.10                   | 40.42                   | $\mu\text{A}$ |
|   |             | All ACMPxH (includes internal Vref, $V_{in+} = 0$ , Vref = 32 mV)                       | 48.95                   | 50.26                   | 53.90                   | $\mu\text{A}$ |
|   |             | ACMP0H 100 $\mu\text{A}$ Enabled (includes internal Vref, $V_{in+} = 0$ , Vref = 32 mV) | 35.95                   | 36.65                   | 38.92                   | $\mu\text{A}$ |
| Any ACMPxL (includes internal Vref, $V_{in+} = 0$ , Vref = 32 mV) | 1.89        | 1.93  | 2.04                    | $\mu\text{A}$           |                         |               |

### 3.7 TIMING CHARACTERISTICS

Table 12: Typical Delay Estimated for Each Macrocell at  $T_A = 25\text{ }^\circ\text{C}$

| Parameter | Description | Note  | $V_{DD} = 2.5\text{ V}$ |         | $V_{DD} = 3.3\text{ V}$ |         | $V_{DD} = 5.0\text{ V}$ |         | Unit |
|-----------|-------------|---|-------------------------|---------|-------------------------|---------|-------------------------|---------|------|
|           |             |   | Rising                  | Falling | Rising                  | Falling | Rising                  | Falling |      |
| tpd       | Delay       | Digital Input to PP 1x                      | 23                      | 26      | 17                      | 19      | 12                      | 15      | ns   |
| tpd       | Delay       | Digital Input to PP 2x                      | 22                      | 25      | 16                      | 16      | 12                      | 14      | ns   |
| tpd       | Delay       | Digital Input with Schmitt Trigger to PP 1x | 24                      | 27      | 18                      | 21      | 14                      | 15      | ns   |
| tpd       | Delay       | Low Voltage Digital Input to PP 1x          | 38                      | 241     | 26                      | 164     | 18                      | 104     | ns   |
| tpd       | Delay       | Digital input to NMOS 1x                    | --                      | 24      | --                      | 18      | --                      | 13      | ns   |

**Auto AEC-Q100 Qualified GreenPAK Programmable Mixed-Signal Matrix**
**Table 12: Typical Delay Estimated for Each Macrocell at T<sub>A</sub> = 25 °C(Continued)**

| Parameter | Description | Note                                 | V <sub>DD</sub> = 2.5 V |         | V <sub>DD</sub> = 3.3 V |         | V <sub>DD</sub> = 5 V |         | Unit |
|-----------|-------------|--------------------------------------|-------------------------|---------|-------------------------|---------|-----------------------|---------|------|
|           |             |                                      | Rising                  | Falling | Rising                  | Falling | Rising                | Falling |      |
| tpd       | Delay       | Digital input to NMOS 2x             | --                      | 23      | --                      | 17      | --                    | 13      | ns   |
| tpd       | Delay       | Digital input to NMOS 4x             | --                      | 23      | --                      | 17      | --                    | 13      | ns   |
| tpd       | Delay       | Output enable from Pin, OE Hi-Z to 1 | 23                      | --      | 16                      | --      | 12                    | --      | ns   |
| tpd       | Delay       | Output enable from Pin, OE Hi-Z to 0 | --                      | 22      | --                      | 16      | --                    | 12      | ns   |
| tpd       | Delay       | PP 1x 3 State Hi-Z to 1              | 22                      | --      | 16                      | --      | 12                    | --      | ns   |
| tpd       | Delay       | PP 1x 3 State Hi-Z to 0              | --                      | 22      | --                      | 16      | --                    | 12      | ns   |
| tpd       | Delay       | PP 2x 3 State Hi-Z to 1              | 21                      | --      | 16                      | --      | 12                    | --      | ns   |
| tpd       | Delay       | PP 2x 3 State Hi-Z to 0              | --                      | 21      | --                      | 15      | --                    | 11      | ns   |
| tpd       | Delay       | LATCH Q                              | 16                      | 18      | 11                      | 13      | 8                     | 9       | ns   |
| tpd       | Delay       | LATCH nQ                             | 19                      | 15      | 14                      | 11      | 9                     | 7       | ns   |
| tpd       | Delay       | LATCH nRESET High Q                  | 25                      | 21      | 17                      | 15      | 12                    | 10      | ns   |
| tpd       | Delay       | LATCH nRESET High nQ                 | 22                      | 24      | 16                      | 17      | 11                    | 12      | ns   |
| tpd       | Delay       | LATCH nRESET Low Q                   | 22                      | 23      | 15                      | 16      | 11                    | 12      | ns   |
| tpd       | Delay       | LATCH nRESET Low nQ                  | 24                      | 21      | 17                      | 15      | 12                    | 10      | ns   |
| tpd       | Delay       | LATCH nSET High Q                    | 19                      | 21      | 14                      | 15      | 9                     | 10      | ns   |
| tpd       | Delay       | LATCH nSET High nQ                   | 22                      | 19      | 16                      | 13      | 11                    | 9       | ns   |
| tpd       | Delay       | LATCH nSET Low Q                     | 22                      | 18      | 16                      | 13      | 11                    | 9       | ns   |
| tpd       | Delay       | LATCH nSET Low nQ                    | 19                      | 21      | 14                      | 15      | 9                     | 10      | ns   |
| tpd       | Delay       | Multi-Function LATCH Q               | 19                      | 22      | 14                      | 16      | 9                     | 11      | ns   |
| tpd       | Delay       | Multi-Function LATCH nQ              | 22                      | 19      | 16                      | 13      | 11                    | 9       | ns   |
| tpd       | Delay       | Multi-Function LATCH nRESET Q        | 23                      | 27      | 16                      | 19      | 11                    | 14      | ns   |
| tpd       | Delay       | Multi-Function LATCH nRESET nQ       | 27                      | 23      | 20                      | 17      | 14                    | 11      | ns   |
| tpd       | Delay       | Multi-Function LATCH nSET Q          | 25                      | 21      | 18                      | 15      | 13                    | 10      | ns   |
| tpd       | Delay       | Multi-Function LATCH nSET nQ         | 21                      | 25      | 15                      | 18      | 10                    | 13      | ns   |
| tpd       | Delay       | LATCH3, LATCH12 First Q              | 17                      | 19      | 12                      | 14      | 8                     | 9       | ns   |
| tpd       | Delay       | LATCH3, LATCH12 First nQ             | 20                      | 17      | 14                      | 12      | 10                    | 8       | ns   |
| tpd       | Delay       | LATCH3, LATCH12 First nRESET High Q  | 26                      | 23      | 18                      | 16      | 13                    | 11      | ns   |
| tpd       | Delay       | LATCH3, LATCH12 First nRESET High nQ | 24                      | 26      | 17                      | 18      | 12                    | 13      | ns   |
| tpd       | Delay       | LATCH3, LATCH12 First nRESET Low Q   | 23                      | 25      | 16                      | 18      | 11                    | 12      | ns   |
| tpd       | Delay       | LATCH3, LATCH12 First nRESET Low nQ  | 26                      | 23      | 18                      | 16      | 13                    | 11      | ns   |
| tpd       | Delay       | LATCH3, LATCH12 First nSET High Q    | 21                      | 22      | 15                      | 16      | 10                    | 11      | ns   |
| tpd       | Delay       | LATCH3, LATCH12 First nSET High nQ   | 23                      | 20      | 17                      | 14      | 12                    | 10      | ns   |
| tpd       | Delay       | LATCH3, LATCH12 First nSET Low Q     | 23                      | 20      | 16                      | 14      | 11                    | 10      | ns   |
| tpd       | Delay       | LATCH3, LATCH12 First nSET Low nQ    | 21                      | 23      | 15                      | 16      | 10                    | 11      | ns   |
| tpd       | Delay       | LATCH3, LATCH12 Second Q             | 19                      | 19      | 13                      | 13      | 9                     | 9       | ns   |
| tpd       | Delay       | LATCH3, LATCH12 Second nQ            | 20                      | 18      | 14                      | 13      | 10                    | 9       | ns   |
| tpd       | Delay       | LATCH3, LATCH12 Second nRESET High Q | --                      | 22      | --                      | 16      | --                    | 11      | ns   |

**Auto AEC-Q100 Qualified GreenPAK Programmable Mixed-Signal Matrix**
**Table 12: Typical Delay Estimated for Each Macrocell at T<sub>A</sub> = 25 °C(Continued)**

| Parameter | Description | Note                                  | V <sub>DD</sub> = 2.5 V |         | V <sub>DD</sub> = 3.3 V |         | V <sub>DD</sub> = 5 V |         | Unit |
|-----------|-------------|---------------------------------------|-------------------------|---------|-------------------------|---------|-----------------------|---------|------|
|           |             |                                       | Rising                  | Falling | Rising                  | Falling | Rising                | Falling |      |
| tpd       | Delay       | LATCH3, LATCH12 Second nRESET High nQ | 23                      | --      | 17                      | --      | 12                    | --      | ns   |
| tpd       | Delay       | LATCH3, LATCH12 Second nRESET Low Q   | --                      | 25      | --                      | 18      | --                    | 12      | ns   |
| tpd       | Delay       | LATCH3, LATCH12 Second nRESET Low nQ  | 26                      | --      | 18                      | --      | 13                    | --      | ns   |
| tpd       | Delay       | LATCH3, LATCH12 Second nSET High Q    | 20                      | --      | 14                      | --      | 10                    | --      | ns   |
| tpd       | Delay       | LATCH3, LATCH12 Second nSET High nQ   | --                      | 20      | --                      | 14      | --                    | 10      | ns   |
| tpd       | Delay       | LATCH3, LATCH12 Second nSET Low Q     | 23                      | --      | 16                      | --      | 11                    | --      | ns   |
| tpd       | Delay       | LATCH3, LATCH12 Second nSET Low nQ    | --                      | 22      | --                      | 16      | --                    | 11      | ns   |
| tpd       | Delay       | 2-bit LUT                             | 15                      | 16      | 11                      | 11      | 7                     | 8       | ns   |
| tpd       | Delay       | 3-bit LUT                             | 16                      | 17      | 11                      | 12      | 8                     | 8       | ns   |
| tpd       | Delay       | 4-bit LUT                             | 19                      | 17      | 13                      | 12      | 9                     | 9       | ns   |
| tpd       | Delay       | Multi-Function 3-bit LUT              | 18                      | 21      | 13                      | 15      | 9                     | 11      | ns   |
| tpd       | Delay       | Multi-Function 3-bit LUT, CNT Delay   | 46                      | 47      | 33                      | 34      | 23                    | 24      | ns   |
| tpd       | Delay       | Multi-Function 4-bit LUT              | 21                      | 23      | 15                      | 17      | 10                    | 12      | ns   |
| tpd       | Delay       | Multi-Function 4-bit LUT, CNT Delay   | 48                      | 46      | 34                      | 34      | 23                    | 24      | ns   |
| tpd       | Delay       | Edge detect                           | 19                      | 20      | 13                      | 14      | 9                     | 9       | ns   |
| tw        | Width       | Edge detect                           | 211                     | 212     | 156                     | 157     | 115                   | 115     | ns   |
| tpd       | Delay       | Edge detect Delayed                   | 231                     | 235     | 170                     | 173     | 124                   | 126     | ns   |
| tpd       | Delay       | Ripple CNT CLK DOWN Q0                | 18                      | 16      | 13                      | 11      | 9                     | 8       | ns   |
| tpd       | Delay       | Ripple CNT CLK DOWN Q1                | 29                      | 22      | 20                      | 16      | 14                    | 11      | ns   |
| tpd       | Delay       | Ripple CNT CLK DOWN Q2                | 27                      | 29      | 20                      | 21      | 14                    | 14      | ns   |
| tpd       | Delay       | Ripple CNT CLK UP Q0                  | 18                      | 16      | 13                      | 11      | 9                     | 8       | ns   |
| tpd       | Delay       | Ripple CNT CLK UP Q1                  | 24                      | 24      | 17                      | 17      | 12                    | 12      | ns   |
| tpd       | Delay       | Ripple CNT CLK UP Q2                  | 29                      | 23      | 21                      | 17      | 15                    | 12      | ns   |
| tpd       | Delay       | Ripple CNT nSET DOWN Q0               | 26                      | 33      | 19                      | 23      | 14                    | 16      | ns   |
| tpd       | Delay       | Ripple CNT nSET DOWN Q1               | 26                      | 41      | 19                      | 29      | 13                    | 21      | ns   |
| tpd       | Delay       | Ripple CNT nSET DOWN Q2               | 25                      | 41      | 18                      | 29      | 13                    | 20      | ns   |
| tpd       | Delay       | Ripple CNT nSET UP Q0                 | 26                      | 33      | 19                      | 23      | 14                    | 16      | ns   |
| tpd       | Delay       | Ripple CNT nSET UP Q1                 | 26                      | 38      | 19                      | 27      | 13                    | 19      | ns   |
| tpd       | Delay       | Ripple CNT nSET UP Q2                 | 25                      | 44      | 18                      | 32      | 13                    | 22      | ns   |
| tpd       | Delay       | DFF Q                                 | 17                      | 17      | 12                      | 12      | 8                     | 8       | ns   |
| tpd       | Delay       | DFF nQ                                | 18                      | 16      | 13                      | 11      | 9                     | 8       | ns   |
| tpd       | Delay       | DFF nRESET High Q                     | --                      | 20      | --                      | 14      | --                    | 10      | ns   |
| tpd       | Delay       | DFF nRESET High nQ                    | 21                      | --      | 15                      | --      | 10                    | --      | ns   |
| tpd       | Delay       | DFF nRESET Low Q                      | --                      | 22      | --                      | 16      | --                    | 11      | ns   |
| tpd       | Delay       | DFF nRESET Low nQ                     | 23                      | --      | 17                      | --      | 12                    | --      | ns   |
| tpd       | Delay       | DFF nSET High Q                       | 21                      | --      | 15                      | --      | 10                    | --      | ns   |

**Auto AEC-Q100 Qualified GreenPAK Programmable Mixed-Signal Matrix**
**Table 12: Typical Delay Estimated for Each Macrocell at T<sub>A</sub> = 25 °C(Continued)**

| Parameter | Description | Note                              | V <sub>DD</sub> = 2.5 V |         | V <sub>DD</sub> = 3.3 V |         | V <sub>DD</sub> = 5 V |         | Unit |
|-----------|-------------|-----------------------------------|-------------------------|---------|-------------------------|---------|-----------------------|---------|------|
|           |             |                                   | Rising                  | Falling | Rising                  | Falling | Rising                | Falling |      |
| tpd       | Delay       | DFF nSET High nQ                  | --                      | 20      | --                      | 14      | --                    | 10      | ns   |
| tpd       | Delay       | DFF nSET Low Q                    | 23                      | --      | 16                      | --      | 12                    | --      | ns   |
| tpd       | Delay       | DFF nSET Low nQ                   | --                      | 22      | --                      | 16      | --                    | 11      | ns   |
| tpd       | Delay       | Multi-Function DFF Q              | 19                      | 19      | 13                      | 13      | 9                     | 9       | ns   |
| tpd       | Delay       | Multi-Function DFF nQ             | 20                      | 19      | 14                      | 13      | 9                     | 9       | ns   |
| tpd       | Delay       | Multi-Function DFF nRESET Q       | --                      | 26      | --                      | 19      | --                    | 13      | ns   |
| tpd       | Delay       | Multi-Function DFF nRESET nQ      | 26                      | --      | 19                      | --      | 13                    | --      | ns   |
| tpd       | Delay       | Multi-Function DFF nSET Q         | 26                      | --      | 19                      | --      | 13                    | --      | ns   |
| tpd       | Delay       | Multi-Function DFF nSET nQ        | --                      | 26      | --                      | 19      | --                    | 14      | ns   |
| tpd       | Delay       | DFF3, DFF12 First Q               | 18                      | 18      | 13                      | 13      | 9                     | 9       | ns   |
| tpd       | Delay       | DFF3, DFF12 First nQ              | 19                      | 18      | 14                      | 13      | 9                     | 9       | ns   |
| tpd       | Delay       | DFF3, DFF12 First nRESET High Q   | --                      | 22      | --                      | 15      | --                    | 11      | ns   |
| tpd       | Delay       | DFF3, DFF12 First nRESET High nQ  | 22                      | --      | 16                      | --      | 11                    | --      | ns   |
| tpd       | Delay       | DFF3, DFF12 First nRESET Low Q    | --                      | 24      | --                      | 17      | --                    | 12      | ns   |
| tpd       | Delay       | DFF3, DFF12 First nRESET Low nQ   | 25                      | --      | 18                      | --      | 12                    | --      | ns   |
| tpd       | Delay       | DFF3, DFF12 First nSET High Q     | 22                      | --      | 16                      | --      | 11                    | --      | ns   |
| tpd       | Delay       | DFF3, DFF12 First nSET High nQ    | --                      | 22      | --                      | 15      | --                    | 11      | ns   |
| tpd       | Delay       | DFF3, DFF12 First nSET Low Q      | 24                      | --      | 17                      | --      | 12                    | --      | ns   |
| tpd       | Delay       | DFF3, DFF12 First nSET Low nQ     | --                      | 24      | --                      | 17      | --                    | 12      | ns   |
| tpd       | Delay       | DFF3, DFF12 Second Q              | 20                      | 21      | 14                      | 15      | 10                    | 10      | ns   |
| tpd       | Delay       | DFF3, DFF12 Second nQ             | 21                      | 20      | 15                      | 14      | 11                    | 10      | ns   |
| tpd       | Delay       | DFF3, DFF12 Second nRESET High Q  | --                      | 21      | --                      | 15      | --                    | 10      | ns   |
| tpd       | Delay       | DFF3, DFF12 Second nRESET High nQ | 22                      | --      | 16                      | --      | 11                    | --      | ns   |
| tpd       | Delay       | DFF3, DFF12 Second nRESET Low Q   | --                      | 23      | --                      | 17      | --                    | 12      | ns   |
| tpd       | Delay       | DFF3, DFF12 Second nRESET Low nQ  | 24                      | --      | 17                      | --      | 12                    | --      | ns   |
| tpd       | Delay       | DFF3, DFF12 Second nSET High Q    | 22                      | --      | 15                      | --      | 11                    | --      | ns   |
| tpd       | Delay       | DFF3, DFF12 Second nSET High nQ   | --                      | 21      | --                      | 15      | --                    | 10      | ns   |
| tpd       | Delay       | DFF3, DFF12 Second nSET Low Q     | 24                      | --      | 17                      | --      | 12                    | --      | ns   |
| tpd       | Delay       | DFF3, DFF12 Second nSET Low nQ    | --                      | 23      | --                      | 17      | --                    | 12      | ns   |
| tpd       | Delay       | PGen CLK                          | 16                      | 16      | 12                      | 11      | 8                     | 8       | ns   |
| tpd       | Delay       | PGen nRESET Hi-Z to 0             | --                      | 21      | --                      | 15      | --                    | 11      | ns   |
| tpd       | Delay       | PGen nRESET Hi-Z to 1             | 20                      | --      | 14                      | --      | 10                    | --      | ns   |
| tpd       | Delay       | Pipe Delay Out                    | 23                      | 20      | 16                      | 15      | 11                    | 10      | ns   |
| tpd       | Delay       | Pipe Delay nRESET Out             | 30                      | 28      | 22                      | 21      | 16                    | 15      | ns   |
| tpd       | Delay       | Filter Q                          | 160                     | 140     | 109                     | 98      | 68                    | 65      | ns   |
| tpd       | Delay       | Filter nQ                         | 141                     | 159     | 99                      | 108     | 66                    | 68      | ns   |

**Auto AEC-Q100 Qualified GreenPAK Programmable Mixed-Signal Matrix**
**Table 13: Typical Propagations Delays and Pulse Widths at T<sub>A</sub> = 25 °C**

| Parameter | Description         | Note                                       | V <sub>DD</sub> = 2.5 V | V <sub>DD</sub> = 3.3V | V <sub>DD</sub> = 5.0V | Unit |
|-----------|---------------------|--|-------------------------|------------------------|------------------------|------|
| tw        | Pulse Width, 1 cell | mode: (any)edge detect, edge detect output | 221                     | 163                    | 119                    | ns   |
| tw        | Pulse Width, 2 cell | mode: (any)edge detect, edge detect output | 438                     | 322                    | 234                    | ns   |
| tw        | Pulse Width, 3 cell | mode: (any)edge detect, edge detect output | 652                     | 480                    | 349                    | ns   |
| tw        | Pulse Width, 4 cell | mode: (any)edge detect, edge detect output | 869                     | 639                    | 464                    | ns   |
| time1     | Delay, 1 cell       | mode: (any)edge detect, edge detect output | 18                      | 13                     | 9                      | ns   |
| time1     | Delay, 2 cell       | mode: (any)edge detect, edge detect output | 18                      | 13                     | 9                      | ns   |
| time1     | Delay, 3 cell       | mode: (any)edge detect, edge detect output | 18                      | 13                     | 9                      | ns   |
| time1     | Delay, 4 cell       | mode: (any)edge detect, edge detect output | 18                      | 13                     | 9                      | ns   |
| time2     | Delay, 1 cell       | mode: both edge delay, edge detect output  | 240                     | 176                    | 128                    | ns   |
| time2     | Delay, 2 cell       | mode: both edge delay, edge detect output  | 455                     | 334                    | 243                    | ns   |
| time2     | Delay, 3 cell       | mode: both edge delay, edge detect output  | 672                     | 493                    | 358                    | ns   |
| time2     | Delay, 4 cell       | mode: both edge delay, edge detect output  | 888                     | 673                    | 473                    | ns   |

**Table 14: Typical Filter Rejection Pulse Width at T<sub>A</sub> = 25 °C**

| Parameter                     | V <sub>DD</sub> = 2.5 V | V <sub>DD</sub> = 3.3V | V <sub>DD</sub> = 5.0V | Unit |
|-------------------------------|-------------------------|------------------------|------------------------|------|
| Filtered Pulse Width          | < 127                   | < 86                   | < 54                   | ns   |
| Inverter Filtered Pulse Width | < 109                   | < 77                   | < 52                   | ns   |

**3.8 COUNTER/DELAY CHARACTERISTICS**
**Table 15: Typical Counter/Delay Offset at T<sub>A</sub> = 25 °C**

| Parameter               | OSC Freq             | OSC Power | V <sub>DD</sub> = 2.5 V | V <sub>DD</sub> = 3.3 V | V <sub>DD</sub> = 5.0 V | Unit |
|-------------------------|----------------------|-----------|-------------------------|-------------------------|-------------------------|------|
| Power-On time           | 25 MHz               | auto      | 0.14                    | 0.14                    | 0.14                    | μs   |
| Power-On time           | 2.048 MHz            | auto      | 0.5                     | 0.5                     | 0.4                     | μs   |
| Power-On time           | 2.048 kHz            | auto      | 628                     | 544                     | 466                     | μs   |
| frequency settling time | 25 MHz               | auto      | 4                       | 4                       | 8                       | μs   |
| frequency settling time | 2.048 MHz            | auto      | 0.3                     | 0.4                     | 0.4                     | μs   |
| frequency settling time | 2.048 kHz            | auto      | 660                     | 570                     | 480                     | μs   |
| variable (CLK period)   | 25 MHz               | forced    | 0-40                    | 0-40                    | 0-40                    | ns   |
| variable (CLK period)   | 2.048 MHz            | forced    | 0-0.5                   | 0-0.5                   | 0-0.5                   | μs   |
| variable (CLK period)   | 2.048 kHz            | forced    | 0-488                   | 0-488                   | 0-488                   | μs   |
| tpd (non-delayed edge)  | 25 MHz/<br>2.048 kHz | either    | 35                      | 14                      | 10                      | ns   |



# SLG46855-A

## Auto AEC-Q100 Qualified GreenPAK Programmable Mixed-Signal Matrix

### 3.9 OSCILLATOR CHARACTERISTICS

Table 16: Oscillators Frequency Limits,  $V_{DD} = 2.3\text{ V to }5.5\text{ V}$

| OSC            | Temperature Range  |                    |          |                    |                    |          |
|----------------|--------------------|--------------------|----------|--------------------|--------------------|----------|
|                | +25 °C             |                    |          | -40 °C to +105 °C  |                    |          |
|                | Minimum Value, kHz | Maximum Value, kHz | Error, % | Minimum Value, kHz | Maximum Value, kHz | Error, % |
| 2.048 kHz OSC0 | 2.0150             | 2.0685             | +1.00    | 1.7799             | 2.1085             | +2.95    |
|                |                    |                    | -1.61    |                    |                    | -13.09   |
| 2.048 MHz OSC1 | 2019.42            | 2068.48            | +1.00    | 1947.519           | 2080.775           | +1.60    |
|                |                    |                    | -1.40    |                    |                    | -4.91    |
| 25 MHz OSC2    | 24623              | 25250              | +1.00    | 23655              | 25369              | +1.48    |
|                |                    |                    | -1.51    |                    |                    | -5.38    |

#### 3.9.1 OSC Power-On Delay

Table 17: Oscillators Power-On Delay at  $T_A = -40\text{ °C to }+105\text{ °C}$ , OSC Power Setting: "Auto Power-On"

| Power Supply Range ( $V_{DD}$ ) V | OSC0 2.048 kHz               |                              | OSC1 2.048 MHz    |                   | OSC2 25 MHz       |                   | OSC2 25 MHz Start with Delay |                   |
|-----------------------------------|------------------------------|------------------------------|-------------------|-------------------|-------------------|-------------------|------------------------------|-------------------|
|                                   | Typical Value, $\mu\text{s}$ | Maximum Value, $\mu\text{s}$ | Typical Value, ns | Maximum Value, ns | Typical Value, ns | Maximum Value, ns | Typical Value, ns            | Maximum Value, ns |
| 2.30                              | 698.2                        | 1063.8                       | 527.6             | 562.7             | 44.9              | 61.2              | 144.5                        | 166.0             |
| 2.50                              | 663.6                        | 993.6                        | 505.5             | 542.8             | 39.7              | 53.9              | 142.5                        | 164.9             |
| 3.00                              | 601.9                        | 866.9                        | 471.0             | 510.7             | 31.2              | 42.1              | 140.3                        | 164.8             |
| 3.30                              | 576.1                        | 812.0                        | 457.7             | 498.1             | 28.0              | 37.8              | 139.8                        | 165.4             |
| 3.60                              | 555.7                        | 768.3                        | 447.3             | 487.7             | 25.5              | 34.6              | 139.6                        | 166.2             |
| 4.00                              | 533.8                        | 721.1                        | 436.0             | 475.7             | 23.1              | 31.8              | 139.6                        | 167.2             |
| 5.00                              | 492.0                        | 637.1                        | 415.6             | 454.1             | 19.2              | 26.9              | 139.9                        | 170.1             |
| 5.50                              | 468.7                        | 598.1                        | 408.3             | 446.4             | 18.0              | 26.2              | 139.9                        | 171.3             |

### 3.10 ACMP CHARACTERISTICS

Table 18: ACMP Specifications at  $T_A = -40\text{ °C to }+105\text{ °C}$ ,  $V_{DD} = 2.3\text{ V to }5.5\text{ V}$  Unless Otherwise Noted

| Parameter    | Description              | Note  | Condition | Min  | Typ | Max      | Unit |
|--------------|--------------------------|---|-----------|------|-----|----------|------|
| $V_{ACMP}$   | ACMP Input Voltage Range | Positive Input  |           | 0    | --  | $V_{DD}$ | V    |
|              |                          | Negative Input  |           | 0    | --  | $V_{DD}$ | V    |
| $V_{offset}$ | ACMP Input Offset        | ACMPxH $V_{HYS} = 0\text{ mV}$ , Gain = 1, $V_{ref} = 32\text{ mV to }2016\text{ mV}$ |           | -6.4 | --  | 6.4      | mV   |
|              |                          | ACMPxL $V_{HYS} = 0\text{ mV}$ , Gain = 1, $V_{ref} = 32\text{ mV to }2016\text{ mV}$ |           | -4.6 | --  | 5.3      | mV   |

**Auto AEC-Q100 Qualified GreenPAK Programmable Mixed-Signal Matrix**
**Table 18: ACMP Specifications at  $T_A = -40\text{ }^\circ\text{C}$  to  $+105\text{ }^\circ\text{C}$ ,  $V_{DD} = 2.3\text{ V}$  to  $5.5\text{ V}$  Unless Otherwise Noted(Continued)**

| Parameter          | Description                                       | Note  | Condition                      | Min    | Typ | Max    | Unit             |
|--------------------|---|---|--------------------------------|--------|-----|--------|------------------|
| $t_{\text{start}}$ | ACMP Startup Time                                 | ACMP Power-On delay, Minimal required wake time for the "Wake and Sleep function", for ACMPxH |                                | --     | --  | 37     | $\mu\text{s}$    |
|                    |   | ACMP Power-On delay, Minimal required wake time for the "Wake and Sleep function", for ACMPxL |                                | --     | --  | 294    | $\mu\text{s}$    |
| $V_{\text{HYS}}$   | ACMP0H, ACMP1H<br>Built-in Hysteresis<br>(Note 1) | $V_{\text{HYS}} = 32\text{ mV}$   | $T = 25\text{ }^\circ\text{C}$ | 23.33  | --  | 36.59  | mV               |
|                    |   | $V_{\text{HYS}} = 64\text{ mV}$   | $T = 25\text{ }^\circ\text{C}$ | 55.78  | --  | 68.38  | mV               |
|                    |   | $V_{\text{HYS}} = 192\text{ mV}$  | $T = 25\text{ }^\circ\text{C}$ | 183.67 | --  | 197.36 | mV               |
|                    |   | $V_{\text{HYS}} = 32\text{ mV}$   |                                | 22.03  | --  | 37.25  | mV               |
|                    |   | $V_{\text{HYS}} = 64\text{ mV}$   |                                | 54.12  | --  | 68.99  | mV               |
|                    |   | $V_{\text{HYS}} = 192\text{ mV}$  |                                | 182.73 | --  | 197.57 | mV               |
|                    | ACMP2L, ACMP3L<br>Built-in Hysteresis<br>(Note 1) | $V_{\text{HYS}} = 32\text{ mV}$   | $T = 25\text{ }^\circ\text{C}$ | 26.96  | --  | 36.84  | mV               |
|                    |   | $V_{\text{HYS}} = 64\text{ mV}$   | $T = 25\text{ }^\circ\text{C}$ | 58.44  | --  | 69.25  | mV               |
|                    |   | $V_{\text{HYS}} = 192\text{ mV}$  | $T = 25\text{ }^\circ\text{C}$ | 186.18 | --  | 198.18 | mV               |
|                    |   | $V_{\text{HYS}} = 32\text{ mV}$   |                                | 25.01  | --  | 36.82  | mV               |
|                    |   | $V_{\text{HYS}} = 64\text{ mV}$   |                                | 57.87  | --  | 69.19  | mV               |
|                    |   | $V_{\text{HYS}} = 192\text{ mV}$  |                                | 184.78 | --  | 198.36 | mV               |
| $R_{\text{sin}}$   | Series Input Resistance                           | Gain = 1x   |                                | --     | 10  | --     | $\text{G}\Omega$ |
|                    |   | Gain = 0.5x   |                                | --     | 2   | --     | $\text{M}\Omega$ |
|                    |   | Gain = 0.33x  |                                | --     | 2   | --     | $\text{M}\Omega$ |
|                    |   | Gain = 0.25x  |                                | --     | 2   | --     | $\text{M}\Omega$ |

**Auto AEC-Q100 Qualified GreenPAK Programmable Mixed-Signal Matrix**
**Table 18: ACMP Specifications at  $T_A = -40\text{ }^\circ\text{C}$  to  $+105\text{ }^\circ\text{C}$ ,  $V_{DD} = 2.3\text{ V}$  to  $5.5\text{ V}$  Unless Otherwise Noted(Continued)**

| Parameter  | Description  | Note  | Condition               | Min  | Typ                     | Max  | Unit          |
|--|--|---|-------------------------|--|-------------------------|--|---------------|
| PROP   | Propagation Delay, Response Time for ACMP0H, ACMP1H                  | Gain = 1, Vref = 32 mV to 2016 mV, Overdrive = 10 mV                | Low to High             | --   | 1.85                    | 13.55  | $\mu\text{s}$ |
|  |  |   | High to Low             | --   | 2.48                    | 10.04  | $\mu\text{s}$ |
|  |  | Gain = 1, Vref = 32 mV to 2016 mV, Overdrive = 100 mV               | Low to High             | --   | 0.54                    | 2.03   | $\mu\text{s}$ |
|  |  |   | High to Low             | --   | 0.53                    | 0.97   | $\mu\text{s}$ |
|  |  | Gain = 1, T = 25 $^\circ\text{C}$ , Vref = 32 mV, Overdrive = 10 mV | Low to High             | --   | 1.46                    | --   | $\mu\text{s}$ |
|  |  |   | High to Low             | --   | 1.75                    | --   | $\mu\text{s}$ |
|  | Gain = 1, T = 25 $^\circ\text{C}$ , Vref = 32 mV, Overdrive = 100 mV | Low to High   | --                      | 0.55   | --                      | $\mu\text{s}$  |               |
|  |  | High to Low   | --                      | 0.53   | --                      | $\mu\text{s}$  |               |
|  | Propagation Delay, Response Time for ACMP2L, ACMP3L                  | Gain = 1, Vref = 32 mV to 2016 mV, Overdrive = 10 mV                | Low to High             | --   | 56.65                   | 128.40   | $\mu\text{s}$ |
|  |  |   | High to Low             | --   | 63.01                   | 141.48   | $\mu\text{s}$ |
|  |  | Gain = 1, Vref = 32 mV to 2016 mV, Overdrive = 100 mV               | Low to High             | --   | 19.73                   | 60.49  | $\mu\text{s}$ |
|  |  |   | High to Low             | --   | 19.33                   | 60.93  | $\mu\text{s}$ |
| Gain = 1, T = 25 $^\circ\text{C}$ , Vref = 32 mV, Overdrive = 10 mV  |  | Low to High   | --                      | 68.15  | --                      | $\mu\text{s}$  |               |
|  |  | High to Low   | --                      | 66.31  | --                      | $\mu\text{s}$  |               |
| Gain = 1, T = 25 $^\circ\text{C}$ , Vref = 32 mV, Overdrive = 100 mV | Low to High  | --  | 27.54                   | --   | $\mu\text{s}$           |  |               |
|  | High to Low  | --  | 27.01                   | --   | $\mu\text{s}$           |  |               |
| G  | Gain error   | G = 1, Vref = 32 mV   |                         | 1  | 1                       | 1  |               |
|  |  | G = 0.5, Vref = 32 mV   |                         | 0.484  | 0.502                   | 0.526  |               |
|  |  | G = 0.33, Vref = 32 mV  |                         | 0.324  | 0.338                   | 0.358  |               |
|  |  | G = 0.25, Vref = 32 mV  |                         | 0.238  | 0.250                   | 0.263  |               |
|  |  | G = 1, Vref = 480 mV  |                         | 1  | 1                       | 1  |               |
|  |  | G = 0.5, Vref = 480 mV  |                         | 0.497  | 0.501                   | 0.504  |               |
|  |  | G = 0.33, Vref = 480 mV   |                         | 0.330  | 0.333                   | 0.337  |               |
|  |  | G = 0.25, Vref = 480 mV   |                         | 0.248  | 0.250                   | 0.253  |               |
| Vref   | Internal Vref0 error<br>Vref0 = 32 mV to 2016 mV,<br>Buffer disabled | $V_{DD} = 4.0\text{ V}$   | T = 25 $^\circ\text{C}$ | -0.85  | --                      | 4.95   | %             |
|  |  |   |                         | Internal Vref0 error<br>Vref0 = 320 mV to 2016 mV,<br>Buffer enabled | $V_{DD} = 4.0\text{ V}$ | T = 25 $^\circ\text{C}$<br>$I_{LOAD} = 1\text{ }\mu\text{A}$ | -7.96         |
|  | $I_{LOAD} = 1\text{ }\mu\text{A}$                                    | -8.66   | --                      |  |                         |  | 2.39          |
|  | Internal Vref1 error<br>Vref1 = 32 mV to 2016 mV,<br>Buffer disabled | $V_{DD} = 4.0\text{ V}$   | T = 25 $^\circ\text{C}$ | -1.79  | --                      | 5.03   | %             |
|  |  |   |                         | Internal Vref1 error<br>Vref1 = 320 mV to 2016 mV,<br>Buffer enabled | $V_{DD} = 4.0\text{ V}$ | T = 25 $^\circ\text{C}$<br>$I_{LOAD} = 1\text{ }\mu\text{A}$ | -6.04         |
| $I_{LOAD} = 1\text{ }\mu\text{A}$                                    | -6.79  | --  | 2.51                    |  |                         |  | %             |

**Auto AEC-Q100 Qualified GreenPAK Programmable Mixed-Signal Matrix**
**Table 18: ACMP Specifications at  $T_A = -40\text{ }^\circ\text{C}$  to  $+105\text{ }^\circ\text{C}$ ,  $V_{DD} = 2.3\text{ V}$  to  $5.5\text{ V}$  Unless Otherwise Noted(Continued)**

| Parameter   | Description          | Note | Condition   | Min  | Typ  | Max   | Unit          |
|---|----------------------|------|---|------|------|-------|---------------|
| Is  | Input Current Source |      | $V_{in} = V_{DD} - 0.7\text{ V}$ ,<br>$V_{DD} = 2.3\text{ V}$ | 23.3 | 94.1 | 117.7 | $\mu\text{A}$ |
|   |                      |      | $V_{in} = V_{DD} - 0.7\text{ V}$ ,<br>$V_{DD} = 2.5\text{ V}$ | 78.4 | 94.9 | 111.4 | $\mu\text{A}$ |
|   |                      |      | $V_{in} = V_{DD} - 0.7\text{ V}$ ,<br>$V_{DD} = 3.3\text{ V}$ | 78.2 | 95.3 | 111.8 | $\mu\text{A}$ |
|   |                      |      | $V_{in} = V_{DD} - 0.7\text{ V}$ ,<br>$V_{DD} = 4.0\text{ V}$ | 78.2 | 95.4 | 112.0 | $\mu\text{A}$ |
|   |                      |      | $V_{in} = V_{DD} - 0.7\text{ V}$ ,<br>$V_{DD} = 5.0\text{ V}$ | 79.4 | 96.5 | 112.9 | $\mu\text{A}$ |
|   |                      |      | $V_{in} = V_{DD} - 0.7\text{ V}$ ,<br>$V_{DD} = 5.5\text{ V}$ | 81.7 | 98.7 | 116.4 | $\mu\text{A}$ |
| <b>Note 1</b> $V_{IL} = V_{in} - V_{HYS}$ , $V_{IH} = V_{in}$ . |                      |      |   |      |      |       |               |

**Auto AEC-Q100 Qualified GreenPAK Programmable Mixed-Signal Matrix**
**3.11 ANALOG TEMPERATURE SENSOR CHARACTERISTICS**

Temperature Sensor typical nonlinearity  $\pm 0.72\%$  for output range 1 and  $\pm 0.42\%$  for output range 2 at  $V_{DD} = 2.3\text{ V to }5.5\text{ V}$ .

**Table 19: TS Output vs Temperature (Output Range 1),  $V_{DD} = 2.3\text{ V to }5.5\text{ V}$** 

| T, °C | Buffer Enabled |         |         | Buffer Disabled |         |         |
|-------|----------------|---------|---------|-----------------|---------|---------|
|       | Min, mV        | Typ, mV | Max, mV | Min, mV         | Typ, mV | Max, mV |
| -40   | 992            | 997     | 1004    | 992             | 997     | 1005    |
| -20   | 947            | 952     | 960     | 947             | 952     | 960     |
| 0     | 902            | 907     | 914     | 902             | 907     | 914     |
| 20    | 856            | 861     | 868     | 856             | 861     | 868     |
| 25    | 844            | 849     | 856     | 844             | 849     | 856     |
| 40    | 809            | 814     | 821     | 808             | 814     | 821     |
| 60    | 761            | 767     | 775     | 761             | 766     | 775     |
| 80    | 713            | 719     | 727     | 713             | 719     | 727     |
| 100   | 664            | 670     | 679     | 664             | 670     | 679     |
| 105   | 652            | 658     | 667     | 652             | 658     | 667     |

**Table 20: TS Output vs Temperature (Output Range 2),  $V_{DD} = 2.3\text{ V to }5.5\text{ V}$** 

| T, °C | Buffer Enabled |         |         | Buffer Disabled |         |         |
|-------|----------------|---------|---------|-----------------|---------|---------|
|       | Min, mV        | Typ, mV | Max, mV | Min, mV         | Typ, mV | Max, mV |
| -40   | 1192           | 1204    | 1212    | 1193            | 1204    | 1213    |
| -20   | 1143           | 1150    | 1158    | 1143            | 1150    | 1158    |
| 0     | 1088           | 1095    | 1103    | 1088            | 1095    | 1103    |
| 20    | 1033           | 1040    | 1048    | 1033            | 1040    | 1048    |
| 25    | 1019           | 1025    | 1034    | 1019            | 1025    | 1034    |
| 40    | 976            | 983     | 992     | 976             | 983     | 991     |
| 60    | 919            | 926     | 935     | 919             | 926     | 935     |
| 80    | 861            | 868     | 878     | 861             | 868     | 878     |
| 100   | 802            | 810     | 820     | 802             | 810     | 820     |
| 105   | 788            | 795     | 806     | 787             | 795     | 806     |

## SLG46855-A

### Auto AEC-Q100 Qualified GreenPAK Programmable Mixed-Signal Matrix

**Table 21: TS Output Error (Output Range 1),  $V_{DD} = 2.3\text{ V}$  to  $5.5\text{ V}$**

| T, °C | Buffer Enabled |        | Buffer Disabled |        |
|-------|----------------|--------|-----------------|--------|
|       | Min, %         | Max, % | Min, %          | Max, % |
| -40   | -0.56          | 0.70   | -0.57           | 0.73   |
| -20   | -0.56          | 0.75   | -0.56           | 0.76   |
| 0     | -0.58          | 0.78   | -0.58           | 0.78   |
| 20    | -0.59          | 0.81   | -0.59           | 0.80   |
| 25    | -0.61          | 0.84   | -0.61           | 0.84   |
| 40    | -0.64          | 0.92   | -0.65           | 0.92   |
| 60    | -0.72          | 1.03   | -0.73           | 1.06   |
| 80    | -0.79          | 1.15   | -0.79           | 1.17   |
| 100   | -0.89          | 1.33   | -0.90           | 1.33   |
| 105   | -0.91          | 1.40   | -0.91           | 1.35   |

**Table 22: TS Output Error (Output Range 2),  $V_{DD} = 2.3\text{ V}$  to  $5.5\text{ V}$**

| T, °C | Buffer Enabled |        | Buffer Disabled |        |
|-------|----------------|--------|-----------------|--------|
|       | Min, %         | Max, % | Min, %          | Max, % |
| -40   | -0.99          | 0.70   | -0.96           | 0.71   |
| -20   | -0.58          | 0.72   | -0.59           | 0.72   |
| 0     | -0.60          | 0.76   | -0.60           | 0.74   |
| 20    | -0.63          | 0.78   | -0.63           | 0.77   |
| 25    | -0.64          | 0.80   | -0.64           | 0.81   |
| 40    | -0.67          | 0.89   | -0.67           | 0.90   |
| 60    | -0.73          | 1.00   | -0.73           | 0.99   |
| 80    | -0.82          | 1.12   | -0.82           | 1.12   |
| 100   | -0.93          | 1.28   | -0.93           | 1.28   |
| 105   | -0.97          | 1.31   | -0.97           | 1.32   |

Auto AEC-Q100 Qualified GreenPAK Programmable Mixed-Signal Matrix

4 User Programmability

The SLG46855-A is a user programmable device with one time programmable (OTP) memory elements that are able to configure the connection matrix and macrocells. A programming development kit allows the user the ability to create initial devices. Once the design is finalized, the programming code (.gpx file) is forwarded to Renesas Electronics Corporation to integrate into a production process.

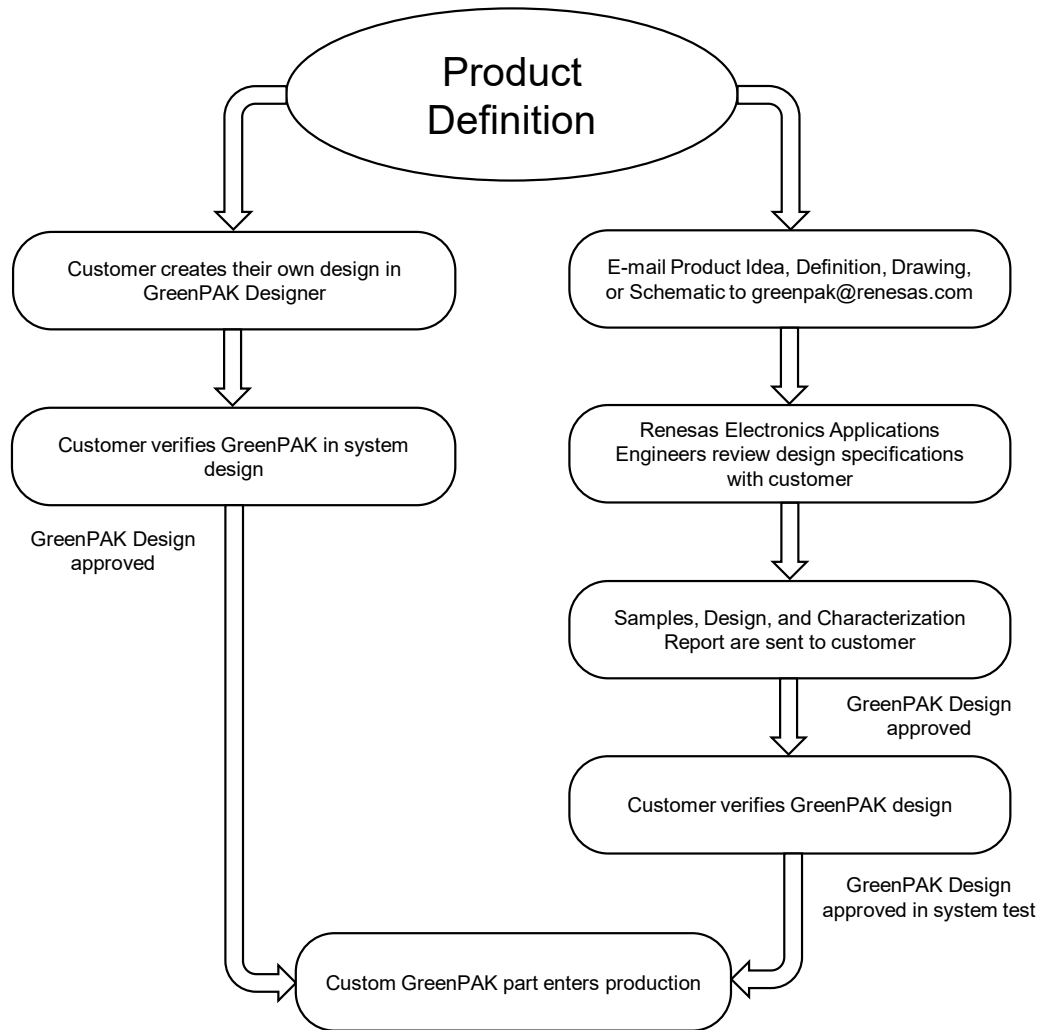

Figure 2: Steps to Create a Custom GreenPAK Device

## SLG46855-A

### Auto AEC-Q100 Qualified GreenPAK Programmable Mixed-Signal Matrix

#### 5 IO Pins

The SLG46855-A has a total of 10 GPIO, 1 GPI, and 1 GPO Pins which can function as either a user defined Input or Output, as well as serving as a special function (such as outputting the voltage reference).

##### 5.1 GPIO PINS

GPIO0, GPIO1, GPIO2, GPIO3, GPIO4, GPIO5, GPIO6, GPIO7, GPIO8 and GPIO9 serve as General Purpose IO Pins.

##### 5.2 GPI PINS

GPI0 serves as a General Purpose Input Pin.

##### 5.3 GPO PINS

GPO0 serves as a General Purpose Output Pin.

##### 5.4 PULL-UP/DOWN RESISTORS

All IO Pins have the option for user selectable resistors connected to the input structure. The selectable values on these resistors are 10 k $\Omega$ , 100 k $\Omega$ , and 1 M $\Omega$ . The internal resistors can be configured as either Pull-up or Pull-downs.

##### 5.5 FAST PULL-UP/DOWN DURING POWER-UP

During power-up, IO Pull-up/down resistance will switch to 2.6 k $\Omega$  initially and then it will switch to normal setting value. This function is enabled by register [778].



SLG46855-A

Auto AEC-Q100 Qualified GreenPAK Programmable Mixed-Signal Matrix

5.6 GPI STRUCTURE

5.6.1 GPI Structure (for GPIO)

Input Mode [1:0]  
 00: Digital In without Schmitt Trigger, wosmt\_en = 1, OE=0  
 01: Digital In with Schmitt Trigger, smt\_en = 1, OE = 0  
 10: Low Voltage Digital In mode, lv\_en = 1, OE = 0  
 11: Reserved

Note 1: OE cannot be selected by user  
 Note 2: OE is Matrix output, Digital In is Matrix input

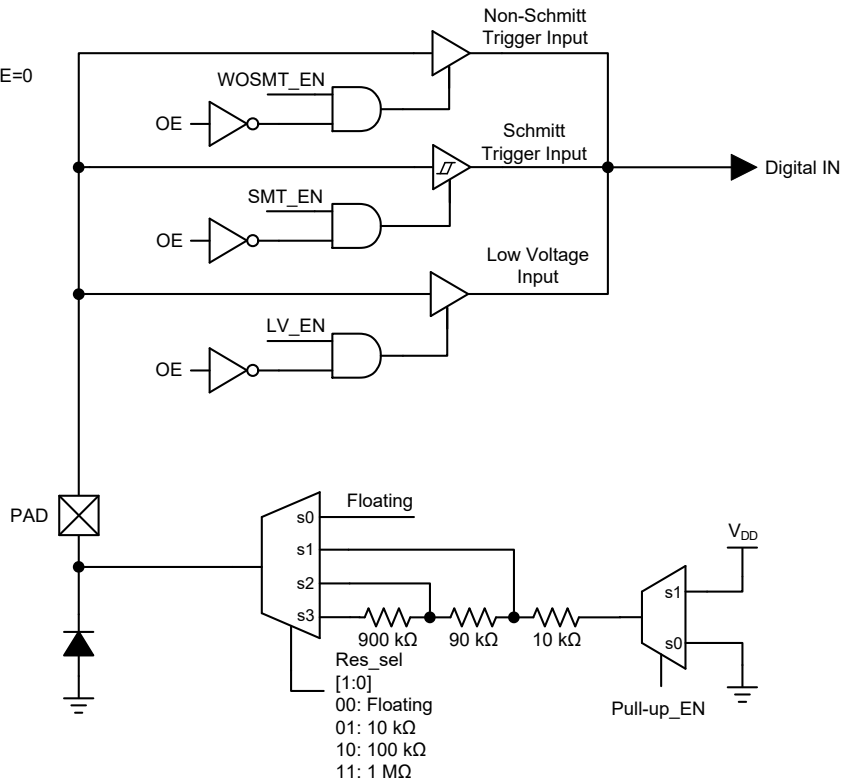

Figure 3: IO0 GPI Structure Diagram

SLG46855-A

Auto AEC-Q100 Qualified GreenPAK Programmable Mixed-Signal Matrix

5.7 GPIO WITH I<sup>2</sup>C MODE IO STRUCTURE

5.7.1 GPIO with I<sup>2</sup>C Mode Structure (for GPIO0 and GPIO1)

IO6, IO7 Mode [2:0]  
 00: Digital Input without Schmitt Trigger  
 01: Digital Input with Schmitt Trigger  
 10: Low Voltage Digital Input  
 11: Reserved

register [790]=1: Open-Drain NMOS for GPIO0  
 register [796]=1: Open-Drain NMOS for GPIO1

Note 1: OE cannot be selected by user and is controlled by register.  
 Digital In is Matrix input.  
 Note 2: GPIO0 and GPIO1 do not support Push-Pull and PMOS Open-Drain modes.  
 Note 3: It is possible to apply an input voltage higher than V<sub>DD</sub> to GPIO0 and GPIO1. However, this voltage should not exceed 5.5 V.  
 Note 4: Can be varied over PVT, for reference only

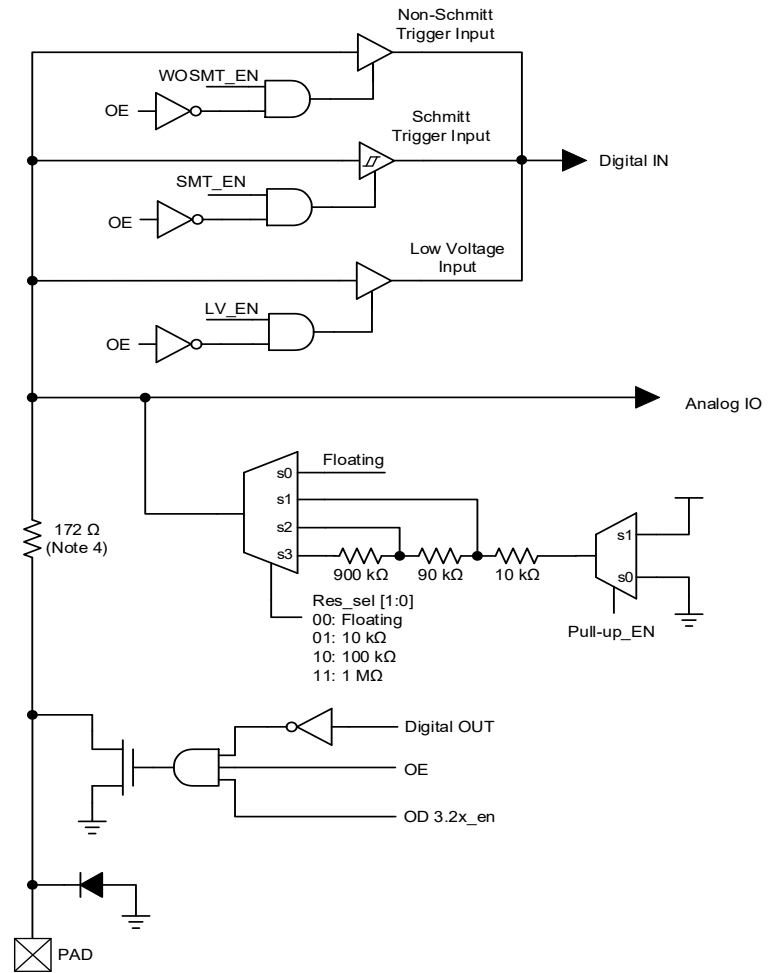

Figure 4: GPIO with I<sup>2</sup>C Mode IO Structure Diagram

# SLG46855-A

## Auto AEC-Q100 Qualified GreenPAK Programmable Mixed-Signal Matrix

### 5.8 MATRIX OE IO STRUCTURE

#### 5.8.1 Matrix OE IO Structure (for GPIO2, GPIO3, GPIO5, GPIO6, GPIO7, GPIO8, and GPIO9)

Input Mode [1:0]  
 00: Digital In without Schmitt Trigger, wosmt\_en = 1  
 01: Digital In with Schmitt Trigger, smt\_en = 1  
 10: Low Voltage Digital In mode, lv\_en = 1  
 11: analog IO mode

Output Mode [1:0]  
 00: Push-Pull 1x mode, pp1x\_en = 1  
 01: Push-Pull 2x mode, pp2x\_en = 1, pp1x\_en = 1  
 10: NMOS 1x Open-Drain mode, od1x\_en = 1  
 11: NMOS 2x Open-Drain mode, od2x\_en = 1, od1x\_en = 1

Note 1: Digital Out and OE are Matrix Output, Digital In is Matrix Input  
 Note 2: Can be varied over PVT, for reference only.

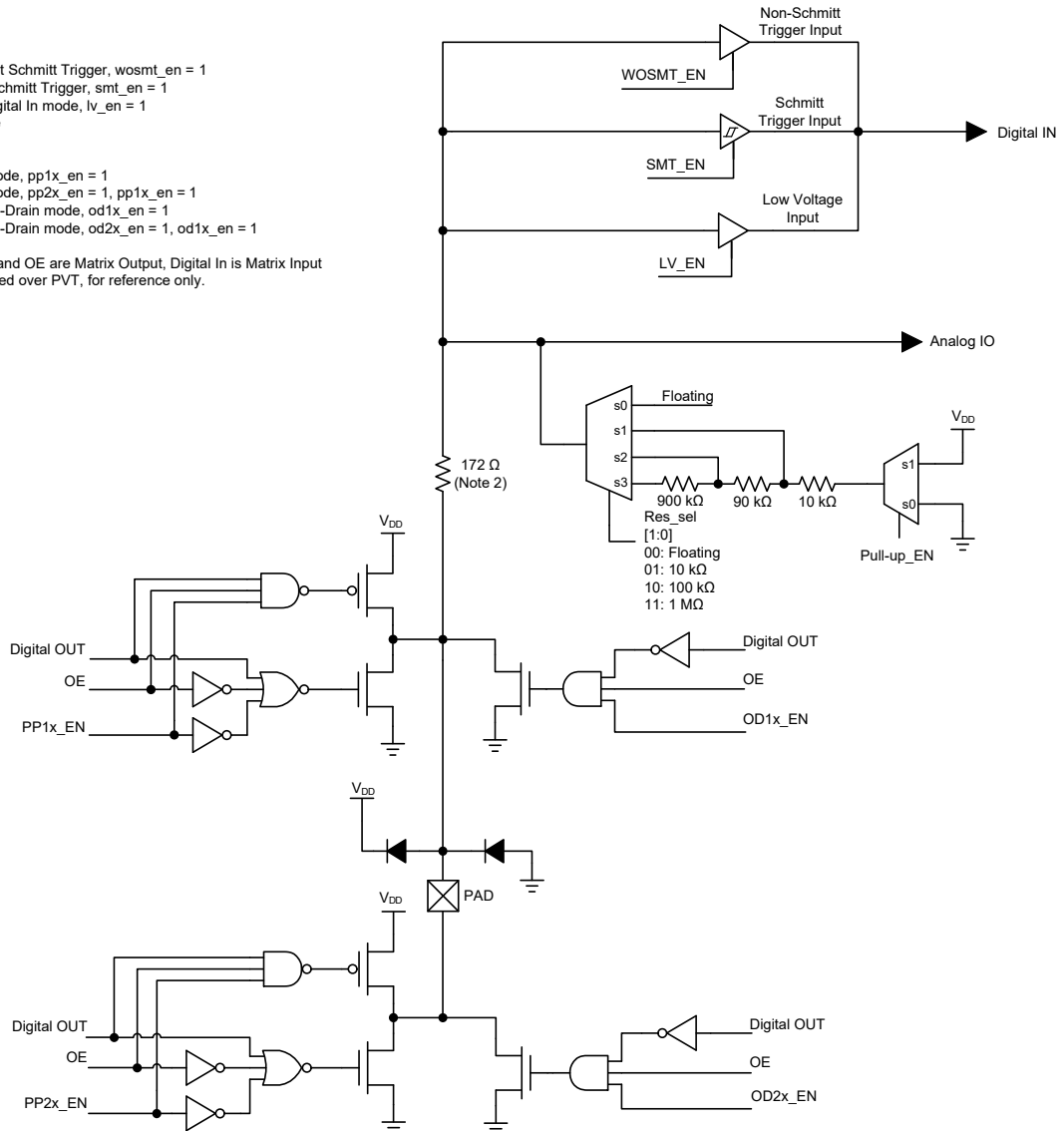

Figure 5: Matrix OE IO Structure Diagram

SLG46855-A

Auto AEC-Q100 Qualified GreenPAK Programmable Mixed-Signal Matrix

5.8.2 Matrix OE 4x Drive Structure (for GPIO4)

Input Mode [1:0]  
 00: Digital In without Schmitt Trigger, wosmt\_en = 1  
 01: Digital In with Schmitt Trigger, smt\_en = 1  
 10: Low Voltage Digital In mode, lv\_en = 1  
 11: Analog IO mode

Output Mode [2:0]  
 Registers [828], [824:823]  
 000: Push-Pull 1x mode (pp1x\_en)  
 001: Push-Pull 2x mode (pp2x\_en)  
 010: NMOS 1x Open-Drain mode (od1x\_en)  
 011: NMOS 2x Open-Drain mode (od2x\_en)  
 100: Reserved  
 101: Push-Pull 4x mode (pp4x\_en)  
 110: Reserved  
 111: NMOS 4x Open-Drain mode (od4x\_en)

Note 1: Digital Out and OE are Matrix output, Digital In is Matrix input  
 Note 2: Can be varied over PVT, for reference only

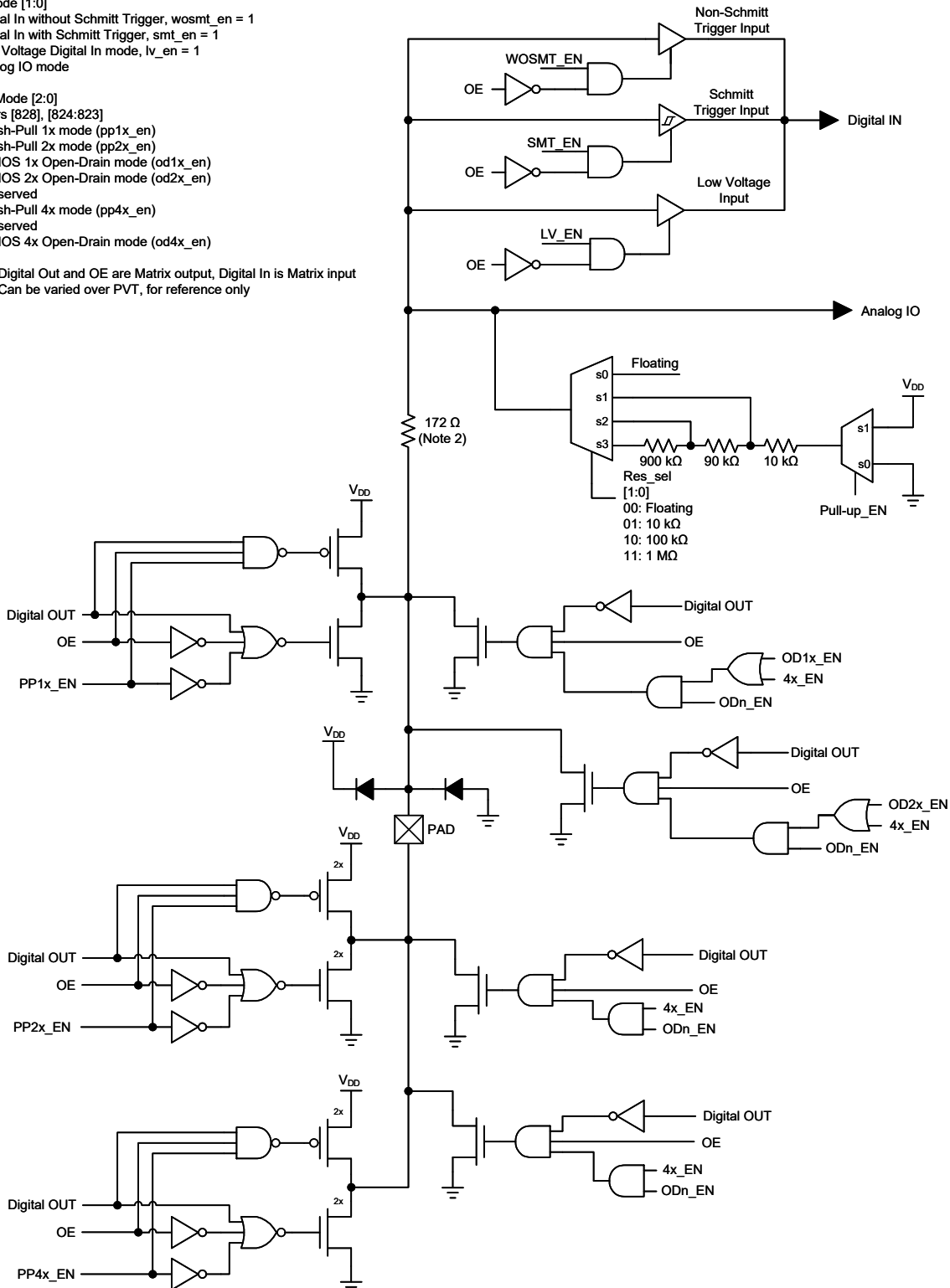

Figure 6: Matrix OE IO 4x Drive Structure Diagram

SLG46855-A

Auto AEC-Q100 Qualified GreenPAK Programmable Mixed-Signal Matrix

5.9 GPO STRUCTURE

5.9.1 GPO Register OE Structure (for GPO0)

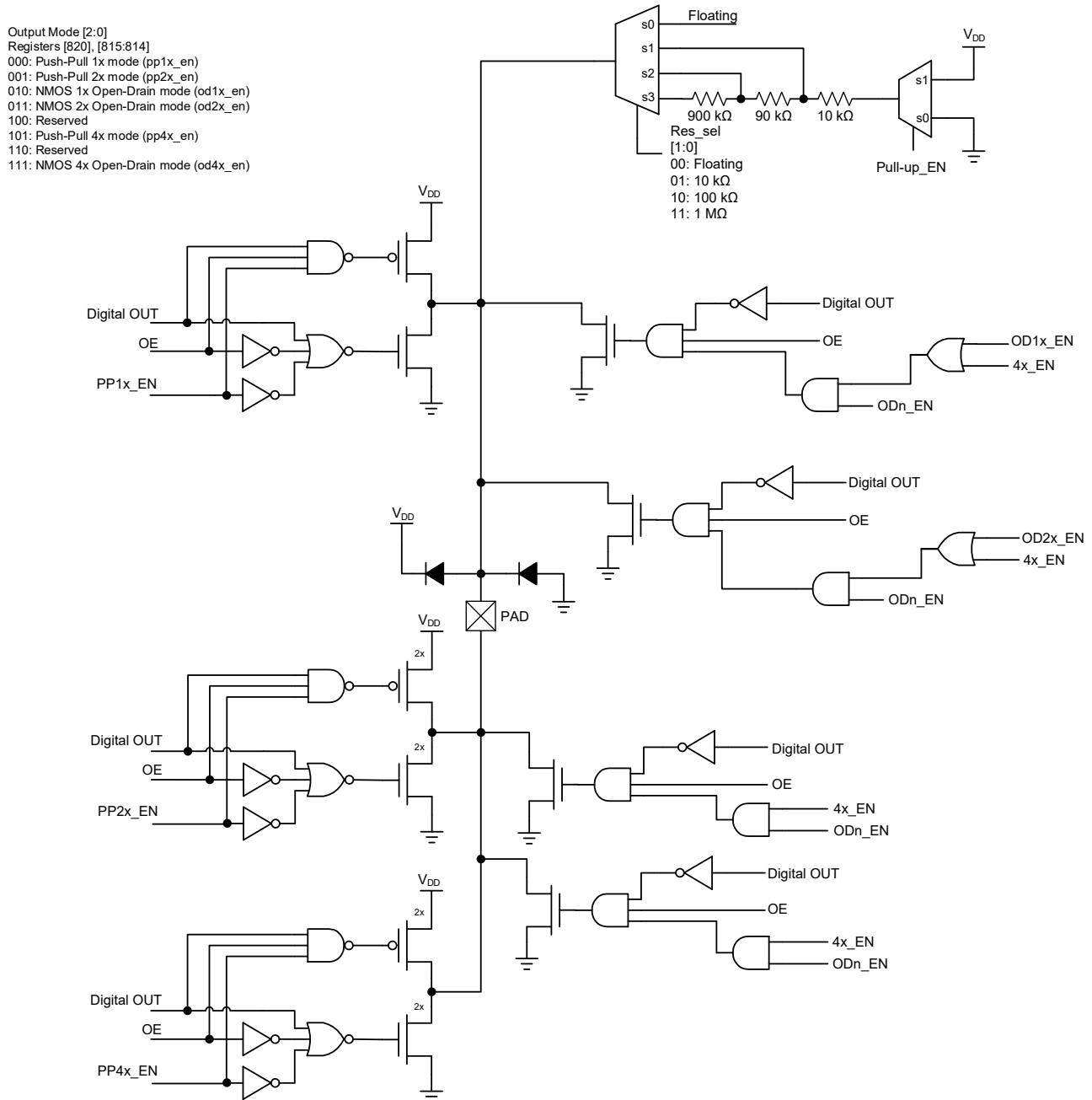

Figure 7: GPO Register OE 4x Drive Structure Diagram

SLG46855-A

Auto AEC-Q100 Qualified GreenPAK Programmable Mixed-Signal Matrix

5.10 IO TYPICAL PERFORMANCE

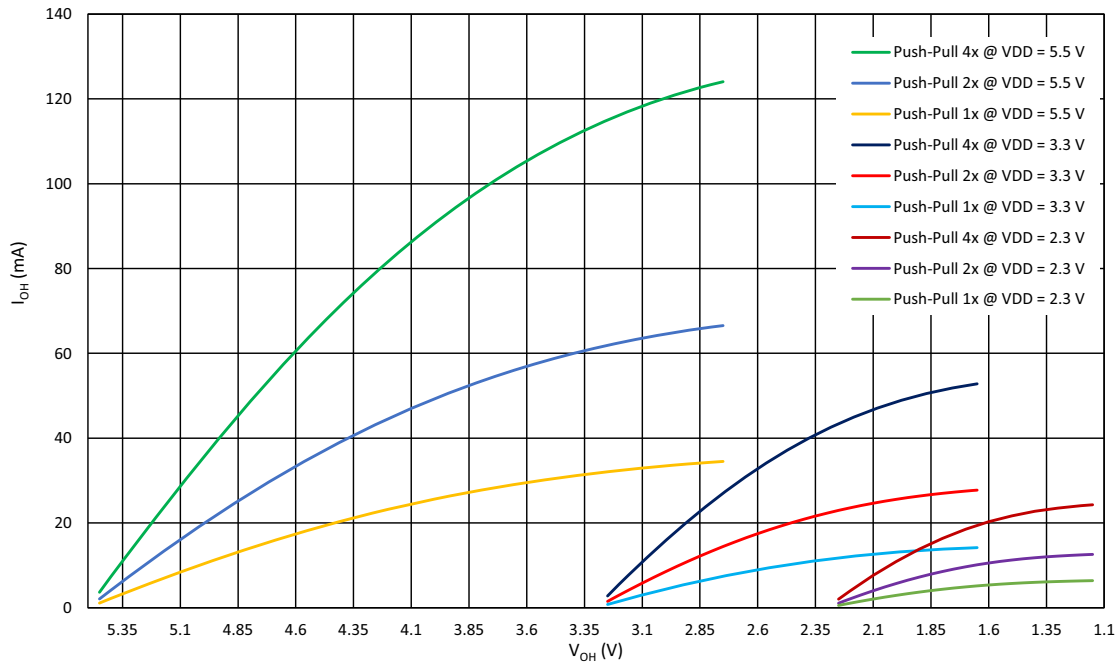

Figure 8: Typical High Level Output Current vs. High Level Output Voltage at T = 25 °C

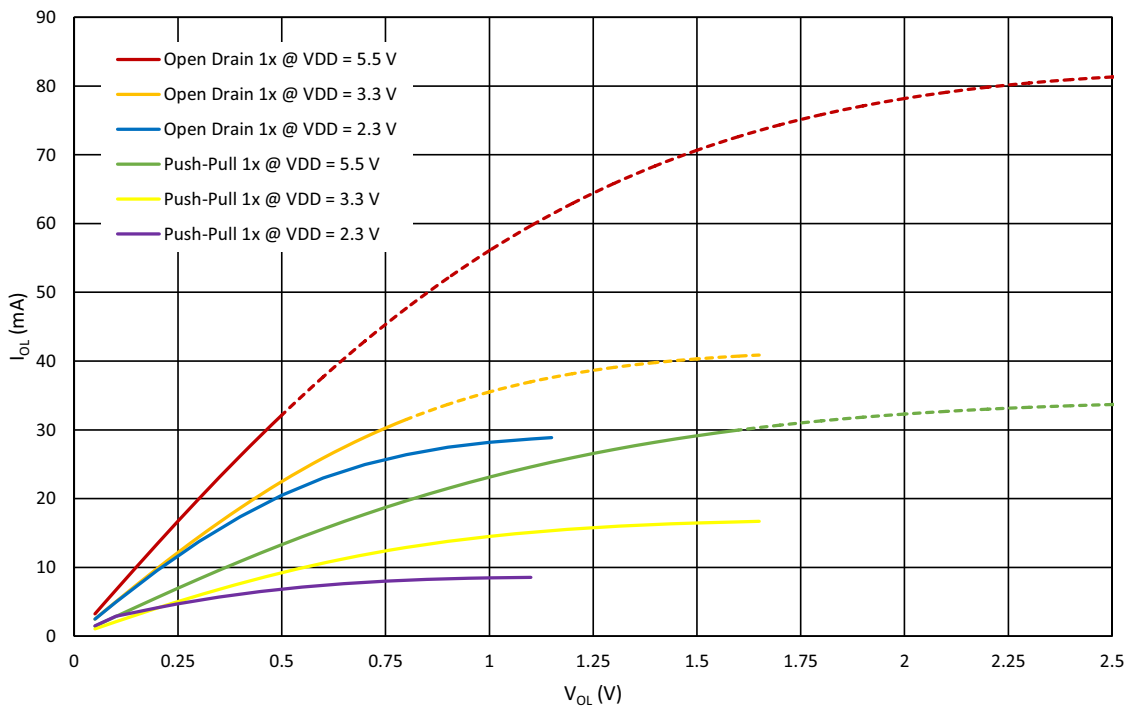

Figure 9: Typical Low Level Output Current vs. Low Level Output Voltage, 1x Drive at T = 25 °C, Full Range

SLG46855-A

Auto AEC-Q100 Qualified GreenPAK Programmable Mixed-Signal Matrix

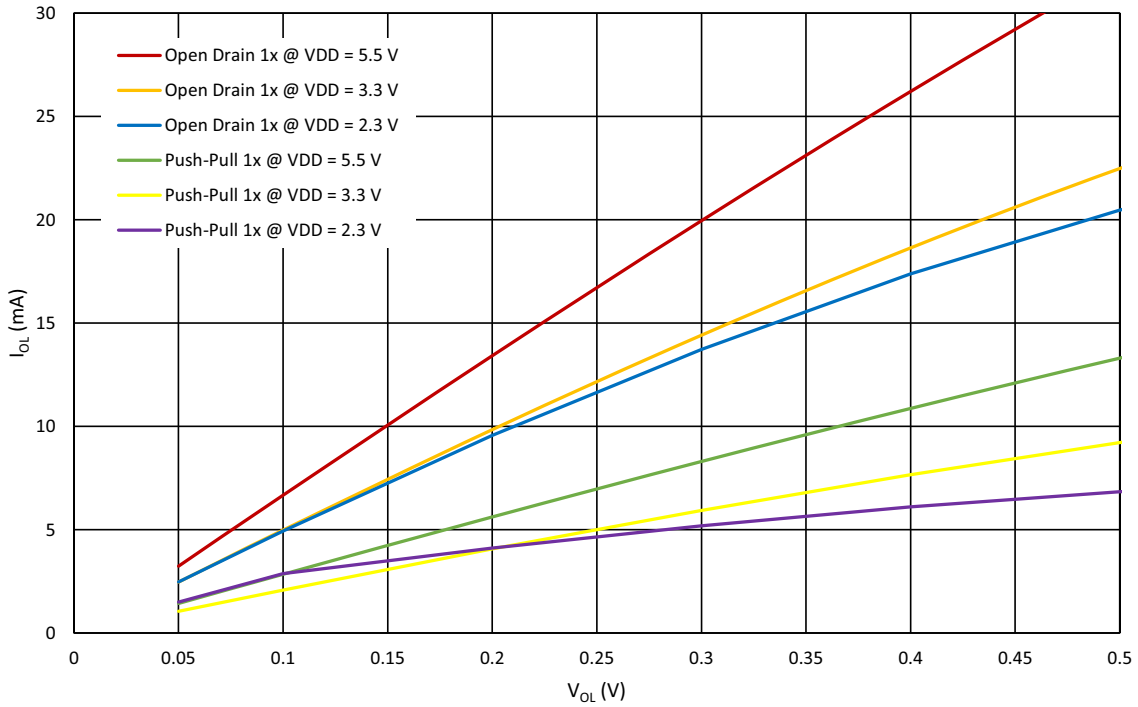

Figure 10: Typical Low Level Output Current vs. Low Level Output Voltage, 1x Drive at T = 25 °C

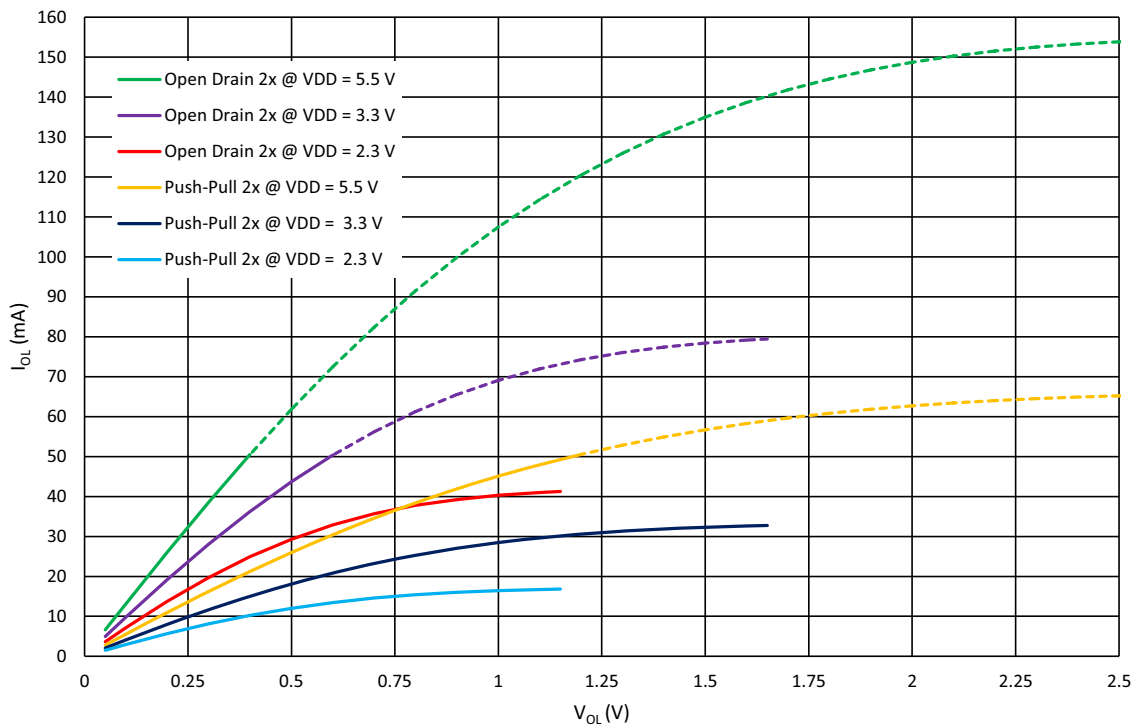

Figure 11: Typical Low Level Output Current vs. Low Level Output Voltage, 2x Drive at T = 25 °C, Full Range

SLG46855-A

Auto AEC-Q100 Qualified GreenPAK Programmable Mixed-Signal Matrix

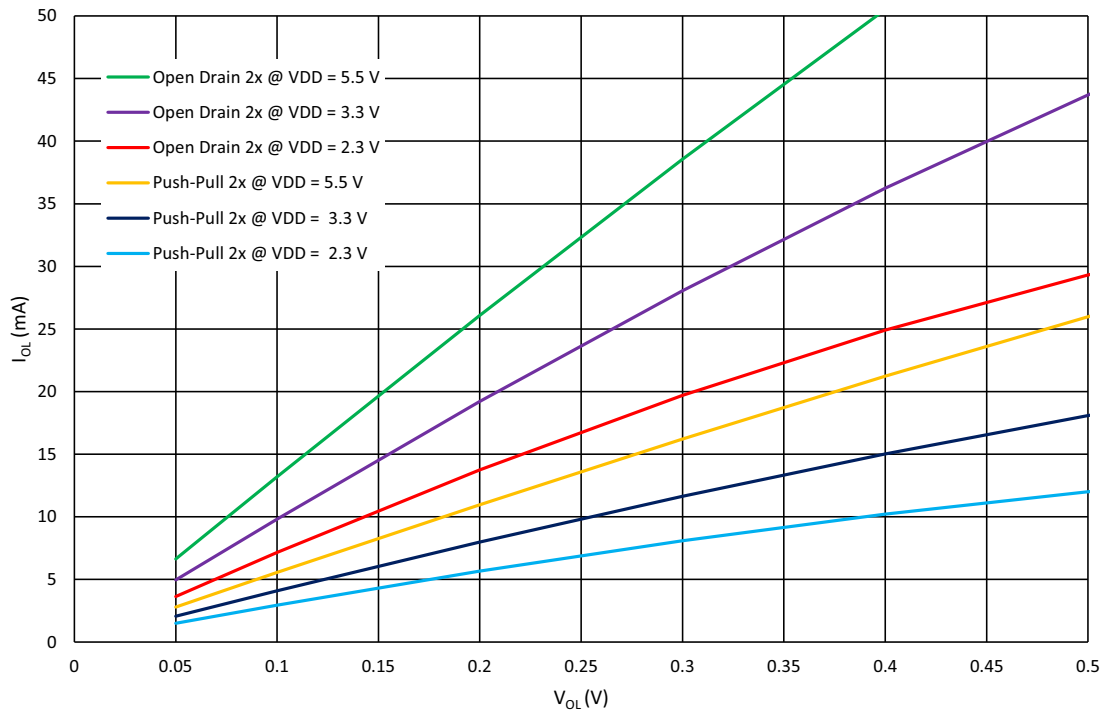

Figure 12: Typical Low Level Output Current vs. Low Level Output Voltage, 2x Drive at T = 25 °C

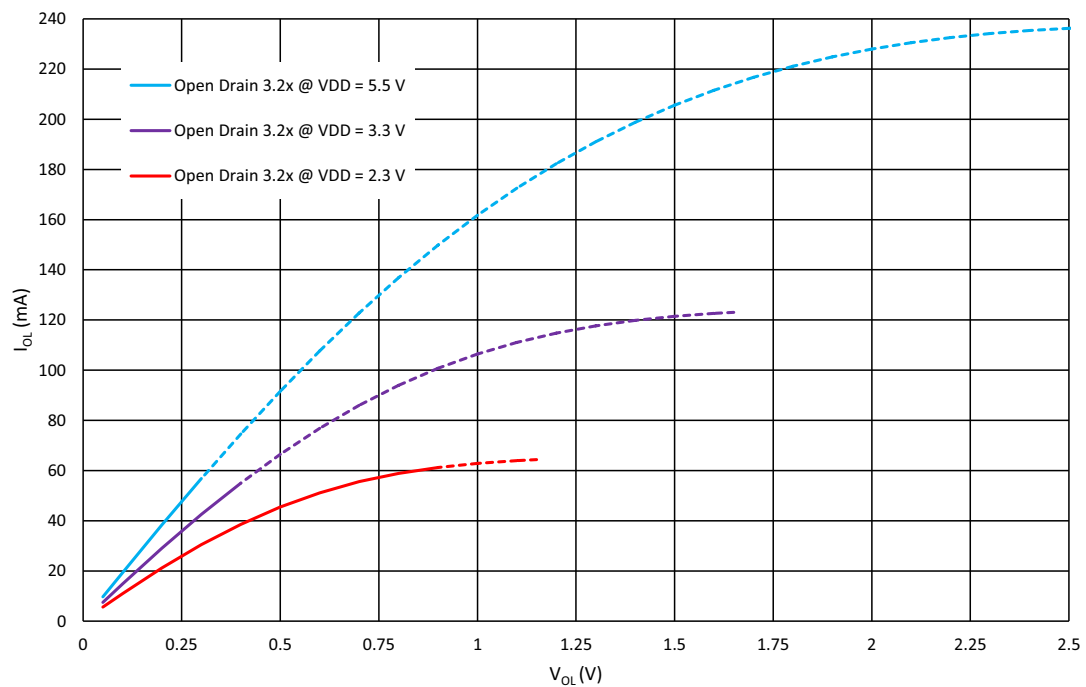

Figure 13: Typical Low Level Output Current vs. Low Level Output Voltage, 3.2x Drive at T = 25 °C, Full Range



SLG46855-A

Auto AEC-Q100 Qualified GreenPAK Programmable Mixed-Signal Matrix

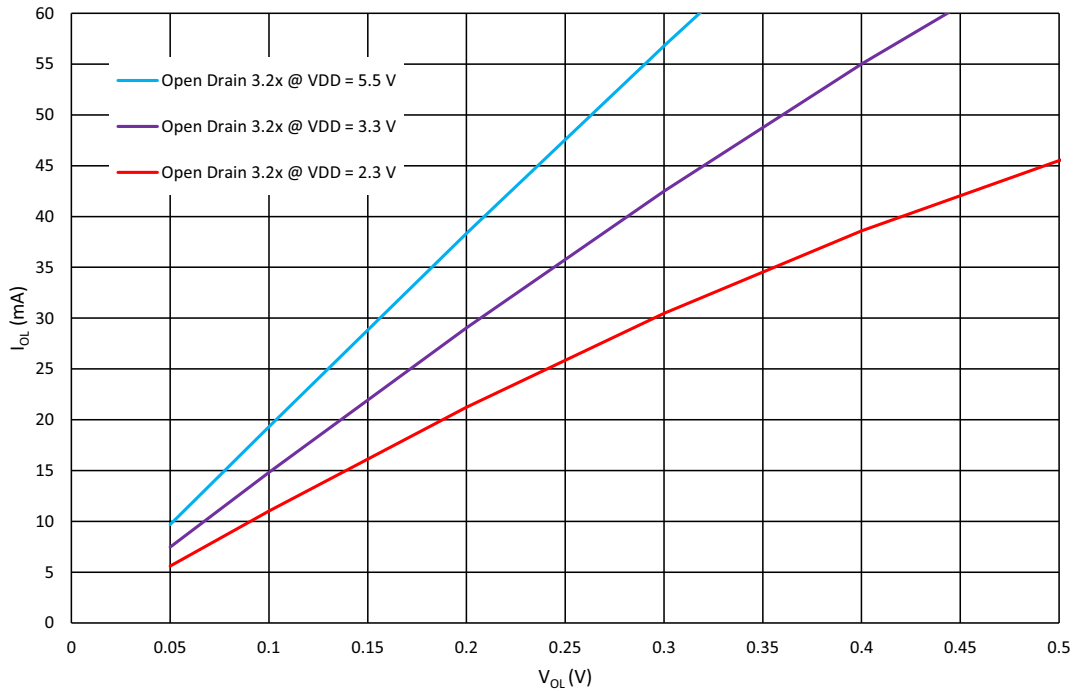

Figure 14: Typical Low Level Output Current vs. Low Level Output Voltage, 3.2x Drive at T = 25 °C

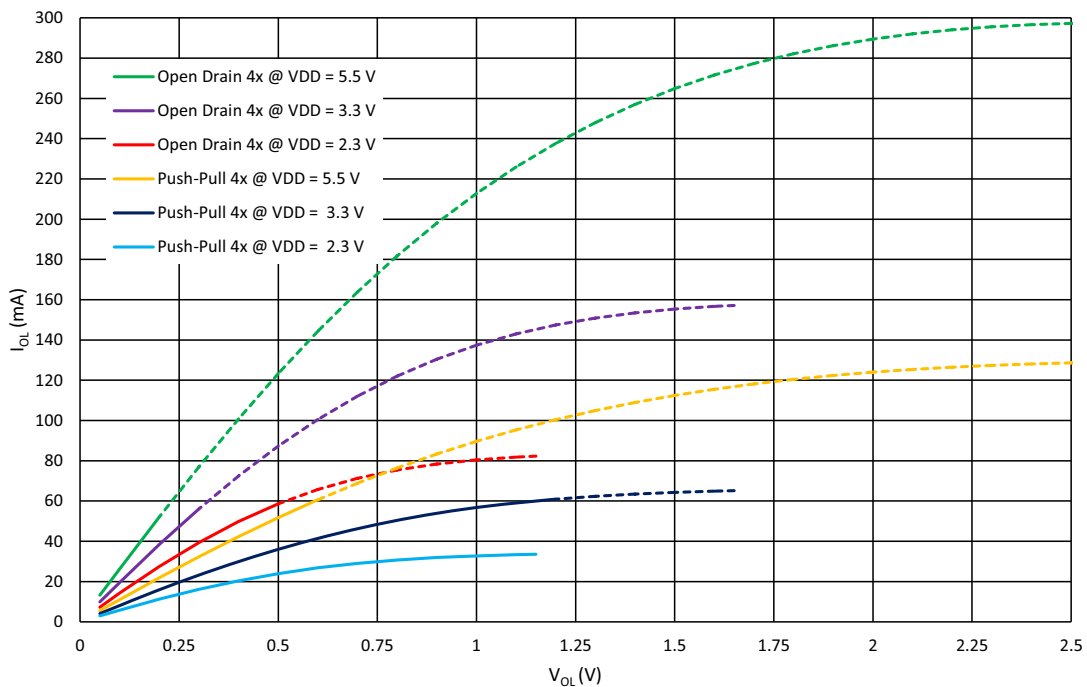

Figure 15: Typical Low Level Output Current vs. Low Level Output Voltage, 4x Drive at T = 25 °C, Full Range

SLG46855-A

Auto AEC-Q100 Qualified GreenPAK Programmable Mixed-Signal Matrix

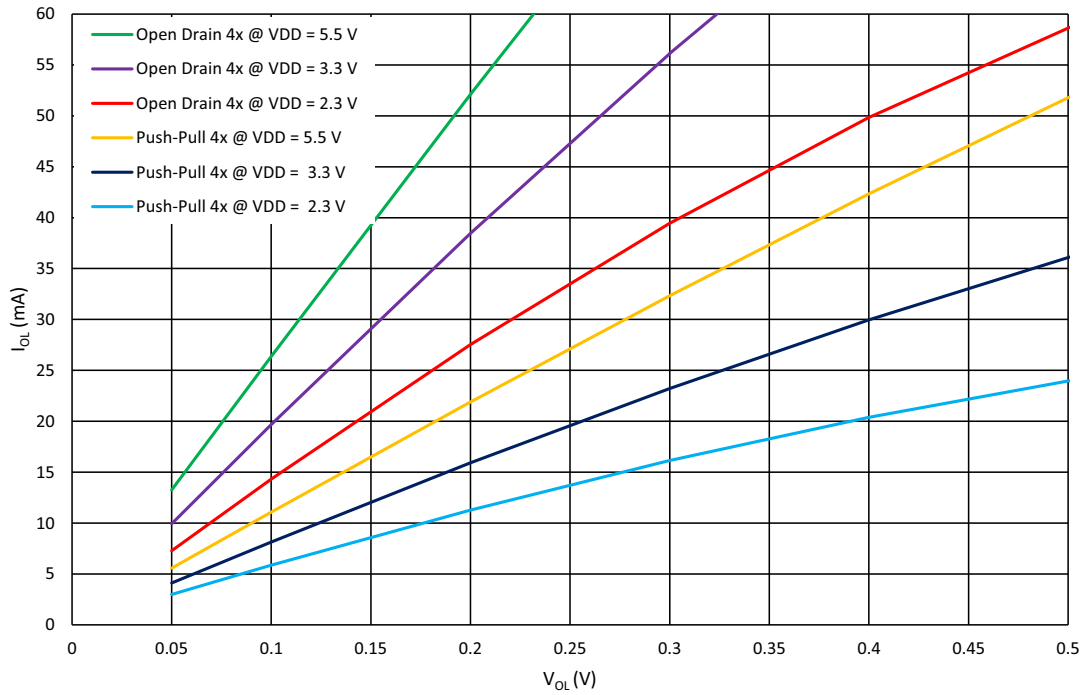

Figure 16: Typical Low Level Output Current vs. Low Level Output Voltage, 4x Drive at T = 25 °C

# SLG46855-A

## Auto AEC-Q100 Qualified GreenPAK Programmable Mixed-Signal Matrix

### 6 Connection Matrix

The Connection Matrix in the SLG46855-A is used to create the internal routing for internal functional macrocells of the device once it is programmed. The registers are programmed from the one time programmable (OTP) NVM cell during Test Mode Operation. The output of each functional macrocell within the SLG46855-A has a specific digital bit code assigned to it that is either set to active “High” or inactive “Low”, based on the design that is created. Once the 2048 register bits within the SLG46855-A are programmed a fully custom circuit will be created.

The Connection Matrix has 64 inputs and 96 outputs. Each of the 64 inputs to the Connection Matrix is hard-wired to the digital output of a particular source macrocell, including IO pins, LUTs, analog comparators, other digital resources, such as V<sub>DD</sub> and GND. The input to a digital macrocell uses a 6-bit register to select one of these 64 input lines.

For a complete list of the SLG46855-A’s register table, see Section 17.

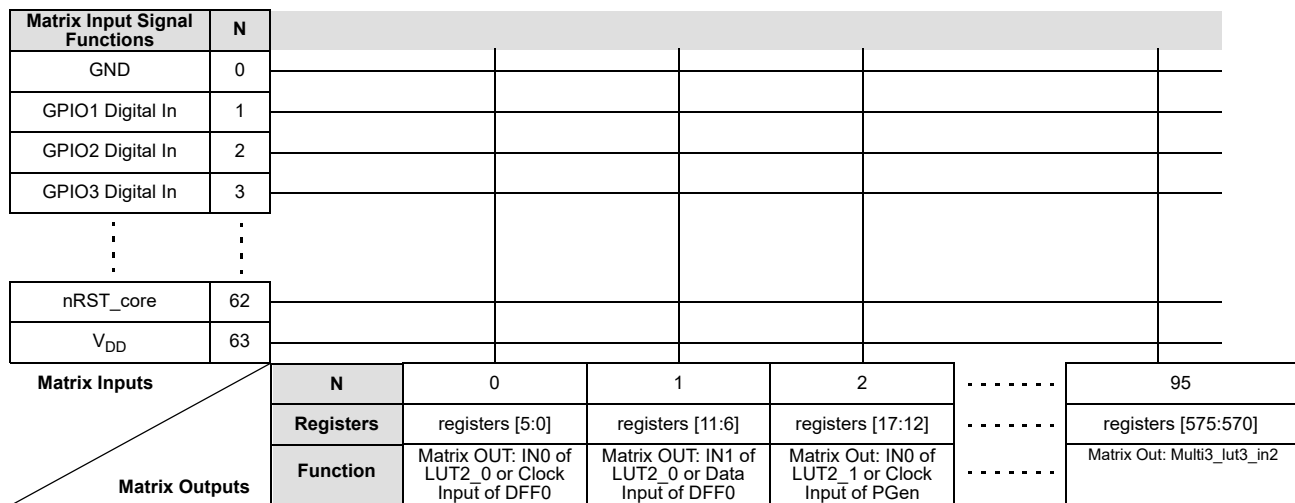

Figure 17: Connection Matrix

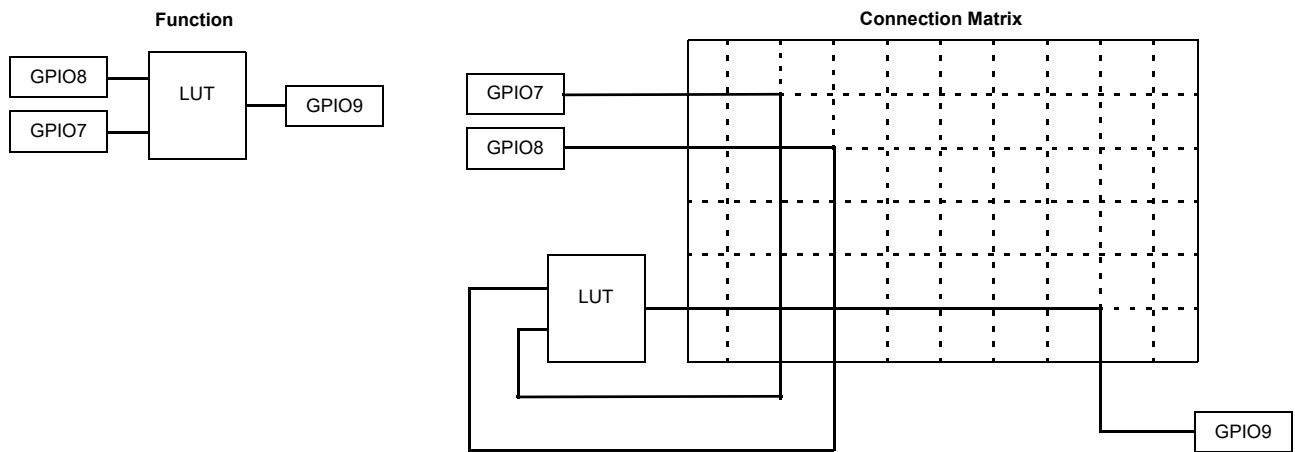

Figure 18: Connection Matrix Example

**Auto AEC-Q100 Qualified GreenPAK Programmable Mixed-Signal Matrix**
**6.1 MATRIX INPUT TABLE**
**Table 23: Matrix Input Table**

| Matrix Input Number | Matrix Input Signal Function                            | Matrix Decode |   |   |   |   |   |
|---------------------|---|---------------|---|---|---|---|---|
|                     |   | 5             | 4 | 3 | 2 | 1 | 0 |
| 0                   | GND   | 0             | 0 | 0 | 0 | 0 | 0 |
| 1                   | LUT2_0/DFF0 output                                      | 0             | 0 | 0 | 0 | 0 | 1 |
| 2                   | LUT2_1/DFF1 output                                      | 0             | 0 | 0 | 0 | 1 | 0 |
| 3                   | LUT2_2/DFF2 output                                      | 0             | 0 | 0 | 0 | 1 | 1 |
| 4                   | LUT2_3/PGen output                                      | 0             | 0 | 0 | 1 | 0 | 0 |
| 5                   | LUT3_0/DFF3 output                                      | 0             | 0 | 0 | 1 | 0 | 1 |
| 6                   | LUT3_1/DFF4 output                                      | 0             | 0 | 0 | 1 | 1 | 0 |
| 7                   | LUT3_2/DFF5 output                                      | 0             | 0 | 0 | 1 | 1 | 1 |
| 8                   | LUT3_3/DFF6 output                                      | 0             | 0 | 1 | 0 | 0 | 0 |
| 9                   | LUT3_4/DFF7 output                                      | 0             | 0 | 1 | 0 | 0 | 1 |
| 10                  | LUT3_5/DFF8 output                                      | 0             | 0 | 1 | 0 | 1 | 0 |
| 11                  | LUT3_6/DFF9 output                                      | 0             | 0 | 1 | 0 | 1 | 1 |
| 12                  | LUT3_7/DFF10 output                                     | 0             | 0 | 1 | 1 | 0 | 0 |
| 13                  | LUT3_8/DFF11 output                                     | 0             | 0 | 1 | 1 | 0 | 1 |
| 14                  | CNT0 output   | 0             | 0 | 1 | 1 | 1 | 0 |
| 15                  | MF0_LUT4/DFF_OUT  | 0             | 0 | 1 | 1 | 1 | 1 |
| 16                  | CNT1 output   | 0             | 1 | 0 | 0 | 0 | 0 |
| 17                  | MF1_LUT3/DFF_OUT  | 0             | 1 | 0 | 0 | 0 | 1 |
| 18                  | CNT2 output   | 0             | 1 | 0 | 0 | 1 | 0 |
| 19                  | MF2_LUT3/DFF_OUT  | 0             | 1 | 0 | 0 | 1 | 1 |
| 20                  | CNT3 output   | 0             | 1 | 0 | 1 | 0 | 0 |
| 21                  | MF3_LUT3/DFF_OUT  | 0             | 1 | 0 | 1 | 0 | 1 |
| 22                  | CNT4 output   | 0             | 1 | 0 | 1 | 1 | 0 |
| 23                  | MF4_LUT3/DFF_OUT  | 0             | 1 | 0 | 1 | 1 | 1 |
| 24                  | CNT5 output   | 0             | 1 | 1 | 0 | 0 | 0 |
| 25                  | MF5_LUT3/DFF_OUT  | 0             | 1 | 1 | 0 | 0 | 1 |
| 26                  | CNT6 output   | 0             | 1 | 1 | 0 | 1 | 0 |
| 27                  | MF6_LUT3/DFF_OUT  | 0             | 1 | 1 | 0 | 1 | 1 |
| 28                  | CNT7 output   | 0             | 1 | 1 | 1 | 0 | 0 |
| 29                  | MF7_LUT3/DFF_OUT  | 0             | 1 | 1 | 1 | 0 | 1 |
| 30                  | LUT3_16/Ripple CNT/Pipe Delay_out0                      | 0             | 1 | 1 | 1 | 1 | 0 |
| 31                  | Ripple CNT/Pipe Delay_out1                              | 0             | 1 | 1 | 1 | 1 | 1 |
| 32                  | GPIO0 digital input or I <sup>2</sup> C_virtual_0 Input | 1             | 0 | 0 | 0 | 0 | 0 |
| 33                  | GPIO1 digital input or I <sup>2</sup> C_virtual_1 Input | 1             | 0 | 0 | 0 | 0 | 1 |
| 34                  | I <sup>2</sup> C_virtual_2 Input                        | 1             | 0 | 0 | 0 | 1 | 0 |
| 35                  | I <sup>2</sup> C_virtual_3 Input                        | 1             | 0 | 0 | 0 | 1 | 1 |
| 36                  | I <sup>2</sup> C_virtual_4 Input                        | 1             | 0 | 0 | 1 | 0 | 0 |
| 37                  | I <sup>2</sup> C_virtual_5 Input                        | 1             | 0 | 0 | 1 | 0 | 1 |

**Auto AEC-Q100 Qualified GreenPAK Programmable Mixed-Signal Matrix**
**Table 23: Matrix Input Table(Continued)**

| Matrix Input Number | Matrix Input Signal Function          | Matrix Decode |   |   |   |   |   |
|---------------------|---------------------------------------|---------------|---|---|---|---|---|
|                     |                                       | 5             | 4 | 3 | 2 | 1 | 0 |
| 38                  | I <sup>2</sup> C_virtual_6 Input      | 1             | 0 | 0 | 1 | 1 | 0 |
| 39                  | I <sup>2</sup> C_virtual_7 Input      | 1             | 0 | 0 | 1 | 1 | 1 |
| 40                  | Ripple CNT_out2                       | 1             | 0 | 1 | 0 | 0 | 0 |
| 41                  | LUT4_0/DFF12 output                   | 1             | 0 | 1 | 0 | 0 | 1 |
| 42                  | Programmable Delay Edge Detect Output | 1             | 0 | 1 | 0 | 1 | 0 |
| 43                  | Edge Detect Filter Output             | 1             | 0 | 1 | 0 | 1 | 1 |
| 44                  | GPIO Digital Input                    | 1             | 0 | 1 | 1 | 0 | 0 |
| 45                  | GPIO2 Digital Input                   | 1             | 0 | 1 | 1 | 0 | 1 |
| 46                  | GPIO3, Digital Input                  | 1             | 0 | 1 | 1 | 1 | 0 |
| 47                  | GPIO4 Digital Input                   | 1             | 0 | 1 | 1 | 1 | 1 |
| 48                  | GPIO5 Digital Input                   | 1             | 1 | 0 | 0 | 0 | 0 |
| 49                  | GPIO6 Digital Input                   | 1             | 1 | 0 | 0 | 0 | 1 |
| 50                  | GPIO7 Digital Input                   | 1             | 1 | 0 | 0 | 1 | 0 |
| 51                  | GPIO8 Digital Input                   | 1             | 1 | 0 | 0 | 1 | 1 |
| 52                  | GPIO9, Digital Input                  | 1             | 1 | 0 | 1 | 0 | 0 |
| 53                  | Oscillator0 output 0                  | 1             | 1 | 0 | 1 | 0 | 1 |
| 54                  | Oscillator1 output 0                  | 1             | 1 | 0 | 1 | 1 | 0 |
| 55                  | Oscillator2 output                    | 1             | 1 | 0 | 1 | 1 | 1 |
| 56                  | ACMP0 Output (normal speed)           | 1             | 1 | 1 | 0 | 0 | 0 |
| 57                  | ACMP1 Output (normal speed)           | 1             | 1 | 1 | 0 | 0 | 1 |
| 58                  | ACMP2 Output (low speed)              | 1             | 1 | 1 | 0 | 1 | 0 |
| 59                  | ACMP3 output (low speed)              | 1             | 1 | 1 | 0 | 1 | 1 |
| 60                  | Oscillator0 output 1                  | 1             | 1 | 1 | 1 | 0 | 0 |
| 61                  | Oscillator1 output 1                  | 1             | 1 | 1 | 1 | 0 | 1 |
| 62                  | POR OUT                               | 1             | 1 | 1 | 1 | 1 | 0 |
| 63                  | V <sub>DD</sub>                       | 1             | 1 | 1 | 1 | 1 | 1 |

**Auto AEC-Q100 Qualified GreenPAK Programmable Mixed-Signal Matrix**
**6.2 MATRIX OUTPUT TABLE**
**Table 24: Matrix Output Table**

| Register Bit Address | Matrix Output Signal Function   | Matrix Output Number |
|----------------------|---|----------------------|
| [5:0]                | IN0 of LUT2_0 or Clock Input of DFF0  | 0                    |
| [11:6]               | IN1 of LUT2_0 or Data Input of DFF0   | 1                    |
| [17:12]              | IN0 of LUT2_1 or Clock Input of DFF1  | 2                    |
| [23:18]              | IN1 of LUT2_1 or Data Input of DFF1   | 3                    |
| [29:24]              | IN0 of LUT2_2 or Clock Input of DFF2  | 4                    |
| [35:30]              | IN1 of LUT2_2 or Data Input of DFF2   | 5                    |
| [41:36]              | IN0 of LUT2_3 or Clock Input of PGen  | 6                    |
| [47:42]              | IN1 of LUT2_3 or nRST of PGen   | 7                    |
| [53:48]              | IN0 of LUT3_0 or CLK Input of DFF3  | 8                    |
| [59:54]              | IN1 of LUT3_0 or Data of DFF3   | 9                    |
| [65:60]              | IN2 of LUT3_0 or nRST (nSET) of DFF3  | 10                   |
| [71:66]              | IN0 of LUT3_1 or CLK Input of DFF4  | 11                   |
| [77:72]              | IN1 of LUT3_1 or Data of DFF4   | 12                   |
| [83:78]              | IN2 of LUT3_1 or nRST (nSET) of DFF4  | 13                   |
| [89:84]              | IN0 of LUT3_2 or CLK Input of DFF5  | 14                   |
| [95:90]              | IN1 of LUT3_2 or Data of DFF5   | 15                   |
| [101:96]             | IN2 of LUT3_2 or nRST (nSET) of DFF5  | 16                   |
| [107:102]            | IN0 of LUT3_3 or CLK Input of DFF6  | 17                   |
| [113:108]            | IN1 of LUT3_3 or Data of DFF6   | 18                   |
| [119:114]            | IN2 of LUT3_3 or nRST (nSET) of DFF6  | 19                   |
| [125:120]            | IN0 of LUT3_4 or CLK Input of DFF7  | 20                   |
| [131:126]            | IN1 of LUT3_4 or Data of DFF7   | 21                   |
| [137:132]            | IN2 of LUT3_4 or Data of DFF7   | 22                   |
| [143:138]            | IN0 of LUT3_5 or CLK Input of DFF8  | 23                   |
| [149:144]            | IN1 of LUT3_5 or Data of DFF8   | 24                   |
| [155:150]            | IN2 of LUT3_5 or nRST (nSET) of DFF8  | 25                   |
| [161:156]            | IN0 of LUT3_6 or CLK Input of DFF9  | 26                   |
| [167:162]            | IN1 of LUT3_6 or Data of DFF9   | 27                   |
| [173:168]            | IN2 of LUT3_6 or nRST (nSET) of DFF9  | 28                   |
| [179:174]            | IN0 of LUT3_7 or CLK Input of DFF10   | 29                   |
| [185:180]            | IN1 of LUT3_7 or Data of DFF10  | 30                   |
| [191:186]            | IN2 of LUT3_7 or nRST (nSET) of DFF10   | 31                   |
| [197:192]            | IN0 of LUT3_8 or CLK Input of DFF11   | 32                   |
| [203:198]            | IN1 of LUT3_8 or CLK Input of DFF11   | 33                   |
| [209:204]            | IN2 of LUT3_8 or nRST (nSET) of DFF11   | 34                   |
| [215:210]            | IN0 of LUT3_12 or CLK Input of DFF16<br>Delay4 Input (or Counter4 nRST Input)   | 35                   |
| [221:216]            | IN1 of LUT3_12 or nRST (nSET) of DFF16<br>Delay4 Input (or Counter4 nRST Input) | 36                   |

**Auto AEC-Q100 Qualified GreenPAK Programmable Mixed-Signal Matrix**
**Table 24: Matrix Output Table(Continued)**

| Register Bit Address | Matrix Output Signal Function   | Matrix Output Number |
|----------------------|---|----------------------|
| [227:222]            | IN2 of LUT3_12 or Data of DFF16<br>Delay4 Input (or Counter4 nRST Input)        | 37                   |
| [233:228]            | IN0 of LUT3_13 or CLK Input of DFF17<br>Delay5 Input (or Counter5 nRST Input)   | 38                   |
| [239:234]            | IN1 of LUT3_13 or nRST (nSET) of DFF17<br>Delay5 Input (or Counter5 nRST Input) | 39                   |
| [245:240]            | IN2 of LUT3_13 or Data of DFF17<br>Delay5 Input (or Counter5 nRST Input)        | 40                   |
| [251:246]            | IN0 of LUT3_14 or CLK Input of DFF18<br>Delay6 Input (or Counter6 nRST Input)   | 41                   |
| [257:252]            | IN1 of LUT3_14 or nRST (nSET) of DFF18<br>Delay6 Input (or Counter6 nRST Input) | 42                   |
| [263:258]            | IN2 of LUT3_14 or Data of DFF18<br>Delay6 Input (or Counter6 nRST Input)        | 43                   |
| [269:264]            | IN0 of LUT3_15 or CLK Input of DFF19<br>Delay7 Input (or Counter7 nRST Input)   | 44                   |
| [275:270]            | IN1 of LUT3_15 or nRST (nSET) of DFF19<br>Delay7 Input (or Counter7 nRST Input) | 45                   |
| [281:276]            | IN2 of LUT3_15 or Data of DFF19<br>Delay7 Input (or Counter7 nRST Input)        | 46                   |
| [287:282]            | IN0 of LUT3_16 or Input of Pipe Delay or UP signal of RIPP CNT                  | 47                   |
| [293:288]            | IN1 of LUT3_16 or nRST of Pipe Delay or nSET of RIPP CNT                        | 48                   |
| [299:294]            | IN2 of LUT3_16 or Clock of Pipe Delay_RIPP CNT                                  | 49                   |
| [305:300]            | IN0 of LUT4_0 or CLK Input of DFF12   | 50                   |
| [311:306]            | IN1 of LUT4_0 or Data of DFF12  | 51                   |
| [317:312]            | IN2 of LUT4_0 or nRST (nSET) of DFF12   | 52                   |
| [323:318]            | IN3 of LUT4_0   | 53                   |
| [329:324]            | Programmable delay/edge detect input  | 54                   |
| [335:330]            | Filter/Edge detect input  | 55                   |
| [341:336]            | GPIO0 Digital Output  | 56                   |
| [347:342]            | GPIO1 Digital Output  | 57                   |
| [353:348]            | GPIO2 Digital Output  | 58                   |
| [359:354]            | GPIO2 Digital Output OE   | 59                   |
| [365:360]            | GPIO3, Digital Output   | 60                   |
| [371:366]            | GPIO3, Digital Output OE  | 61                   |
| [377:372]            | GPO0 Digital Output   | 62                   |
| [383:378]            | GPIO4 Digital Output  | 63                   |
| [389:384]            | GPIO4 Digital Output OE   | 64                   |
| [395:390]            | GPIO5 Digital Output  | 65                   |
| [401:396]            | GPIO5 Digital Output OE   | 66                   |
| [407:402]            | GPIO6 Digital Output  | 67                   |
| [413:408]            | GPIO6 Digital Output OE   | 68                   |

**Auto AEC-Q100 Qualified GreenPAK Programmable Mixed-Signal Matrix**
**Table 24: Matrix Output Table(Continued)**

| Register Bit Address  | Matrix Output Signal Function   | Matrix Output Number |
|---|---|----------------------|
| [419:414]   | GPIO7 Digital Output  | 69                   |
| [425:420]   | GPIO7 Digital Output OE   | 70                   |
| [431:426]   | GPIO8 Digital Output  | 71                   |
| [437:432]   | GPIO8 Digital Output OE   | 72                   |
| [443:438]   | GPIO9, Digital Output   | 73                   |
| [449:444]   | GPIO9 Digital Output OE   | 74                   |
| [455:450]   | PWR UP of ACMP0_H   | 75                   |
| [461:456]   | PWR UP of ACMP1_H   | 76                   |
| [467:462]   | PWR UP of ACMP2_L   | 77                   |
| [473:468]   | PWR UP of ACMP3_L   | 78                   |
| [479:474]   | Temp sensor, Vref Out_0, Vref Out_1 Power Up                                    | 79                   |
| [485:480]   | Oscillator0 ENABLE  | 80                   |
| [491:486]   | Oscillator1 ENABLE  | 81                   |
| [497:492]   | Oscillator2 ENABLE  | 82                   |
| [503:498]   | IN0 of LUT4_1 or CLK Input of DFF20<br>Delay0 Input (or Counter0 nRST Input)    | 83                   |
| [509:504]   | IN1 of LUT4_1 or nRST of DFF20<br>Delay0 Input (or Counter0 nRST Input)         | 84                   |
| [515:510]   | IN2 of LUT4_1 or nSET of DFF20<br>Delay0 Input (or Counter0 nRST Input)         | 85                   |
| [521:516]   | IN3 of LUT4_1 or Data of DFF20<br>Delay0 Input (or Counter0 nRST Input)         | 86                   |
| [527:522]   | IN0 of LUT3_9 or CLK Input of DFF13<br>Delay1 Input (or Counter1 nRST Input)    | 87                   |
| [533:528]   | IN1 of LUT3_9 or nRST (nSET) of DFF13<br>Delay1 Input (or Counter1 nRST Input)  | 88                   |
| [539:523]   | IN2 of LUT3_9 or Data of DFF13<br>Delay1 Input (or Counter1 nRST Input)         | 89                   |
| [545:540]   | IN0 of LUT3_10 or CLK Input of DFF14<br>Delay2 Input (or Counter2 nRST Input)   | 90                   |
| [551:546]   | IN1 of LUT3_10 or nRST (nSET) of DFF14<br>Delay2 Input (or Counter2 nRST Input) | 91                   |
| [557:552]   | IN2 of LUT3_10 or Data of DFF14<br>Delay2 Input (or Counter2 nRST Input)        | 92                   |
| [563:558]   | IN0 of LUT3_11 or CLK Input of DFF15<br>Delay3 Input (or Counter3 nRST Input)   | 93                   |
| [569:564]   | IN1 of LUT3_11 or nRST (nSET) of DFF15<br>Delay3 Input (or Counter3 nRST Input) | 94                   |
| [575:570]   | IN2 of LUT3_11 or Data of DFF15<br>Delay3 Input (or Counter3 nRST Input)        | 95                   |
| <b>Note 1</b> For each Address, the two most significant bits are unused. |   |                      |



**Auto AEC-Q100 Qualified GreenPAK Programmable Mixed-Signal Matrix**
**6.3 CONNECTION MATRIX VIRTUAL INPUTS**

As mentioned previously, the Connection Matrix inputs come from the outputs of various digital macrocells on the device. Eight of the Connection Matrix inputs have the special characteristic that the state of these signal lines comes from a corresponding data bit written as a register value via I<sup>2</sup>C. This gives the user the ability to write data via the serial channel, and have this information translated into signals that can be driven into the Connection Matrix and from the Connection Matrix to the digital inputs of other macrocells on the device. The I<sup>2</sup>C address for reading and writing these register values is at byte 0x4C (076).

Six of the eight Connection Matrix Virtual Inputs are dedicated to this virtual input function. An I<sup>2</sup>C write command to these register bits will set the signal values going into the Connection Matrix to the desired state. A read command to these register bits will read either the original data values coming from the NVM memory bits (that were loaded during the initial device startup), or the values from a previous write command (if that has happened).

Two of the eight Connection Matrix Virtual Inputs are shared with Pin digital inputs (GPIO0Digital or I<sup>2</sup>C\_virtual\_0 Input), and (GPIO1 Digital or I<sup>2</sup>C\_virtual\_1 Input). If the virtual input mode is selected, an I<sup>2</sup>C write command to these register bits will set the signal values going into the Connection Matrix to the desired state. A read command to these register bits will read either the original data values coming from the NVM memory bits (that were loaded during the initial device startup), or the values from a previous write command (if that has happened). The I<sup>2</sup>C disable/enable register bit [2032] selects whether the Connection Matrix input comes from the Pin input or from the virtual register:

- Select SCL & Virtual Input 0 or GPIO0
- Select SDA & Virtual Input 1 or GPIO1

See [Table 24](#) for Connection Matrix Virtual Inputs.

**Table 25: Connection Matrix Virtual Inputs**

| Matrix Input Number | Matrix Input Signal Function     | Register Bit Addresses (d) |
|---------------------|----------------------------------|----------------------------|
| 32                  | I <sup>2</sup> C_virtual_0 Input | [608]                      |
| 33                  | I <sup>2</sup> C_virtual_1 Input | [609]                      |
| 34                  | I <sup>2</sup> C_virtual_2 Input | [610]                      |
| 35                  | I <sup>2</sup> C_virtual_3 Input | [611]                      |
| 36                  | I <sup>2</sup> C_virtual_4 Input | [612]                      |
| 37                  | I <sup>2</sup> C_virtual_5 Input | [613]                      |
| 38                  | I <sup>2</sup> C_virtual_6 Input | [614]                      |
| 39                  | I <sup>2</sup> C_virtual_7 Input | [615]                      |

**6.4 CONNECTION MATRIX VIRTUAL OUTPUTS**

The digital outputs of the various macrocells are routed to the Connection Matrix to enable interconnections to the inputs of other macrocells in the device. At the same time, it is possible to read the state of each of the macrocell outputs as a register value via I<sup>2</sup>C. This option, called Connection Matrix Virtual Outputs, allows the user to remotely read the values of each macrocell output. The I<sup>2</sup>C addresses for reading these register values are bytes 0x48 (072) to 0x4F (079). Write commands to these same register values will be ignored (with the exception of the Virtual Input register bits at byte 0x4C (076)).

# SLG46855-A

## Auto AEC-Q100 Qualified GreenPAK Programmable Mixed-Signal Matrix

### 7 Combination Function Macrocells

The SLG46855-A has 15 combination function macrocells that can serve more than one logic or timing function. In each case, they can serve as a Look Up Table (LUT), or as another logic or timing function. See the list below for the functions that can be implemented in these macrocells.

- Three macrocells that can serve as either 2-bit LUT or as D Flip-Flop
- Nine macrocells that can serve as either 3-bit LUTs or as D Flip-Flops with Set/Reset Input
- One macrocell that can serve as either 3-bit LUT or as Pipe Delay/Ripple Counter
- One macrocell that can serve as either 2-bit LUT or as Programmable Pattern Generator (PGen)
- One macrocell that can serve as either 4-bit LUT or as D Flip-Flop with Set/Reset Input

Inputs/Outputs for the 15 combination function macrocells are configured from the connection matrix with specific logic functions being defined by the state of configuration bits.

When used as a LUT to implement combinatorial logic functions, the outputs of the LUTs can be configured to any user defined function, including the following standard digital logic devices (AND, NAND, OR, NOR, XOR, XNOR).

#### 7.1 2-BIT LUT OR D FLIP-FLOP MACROCELLS

There is one macrocell that can serve as either 2-bit LUT or as D Flip-Flop. When used to implement LUT functions, the 2-bit LUT takes in two input signals from the connection matrix and produce a single output, which goes back into the connection matrix. When used to implement D Flip-Flop function, the two input signals from the connection matrix go to the data (D) and clock (CLK) inputs for the Flip-Flop, with the output going back to the connection matrix.

The operation of the D Flip-Flop and LATCH will follow the functional descriptions below:

DFF: CLK is rising edge triggered, then Q = D; otherwise Q will not change

LATCH: when CLK is Low, then Q = D; otherwise Q remains its previous value (input D has no effect on the output, when CLK is High).

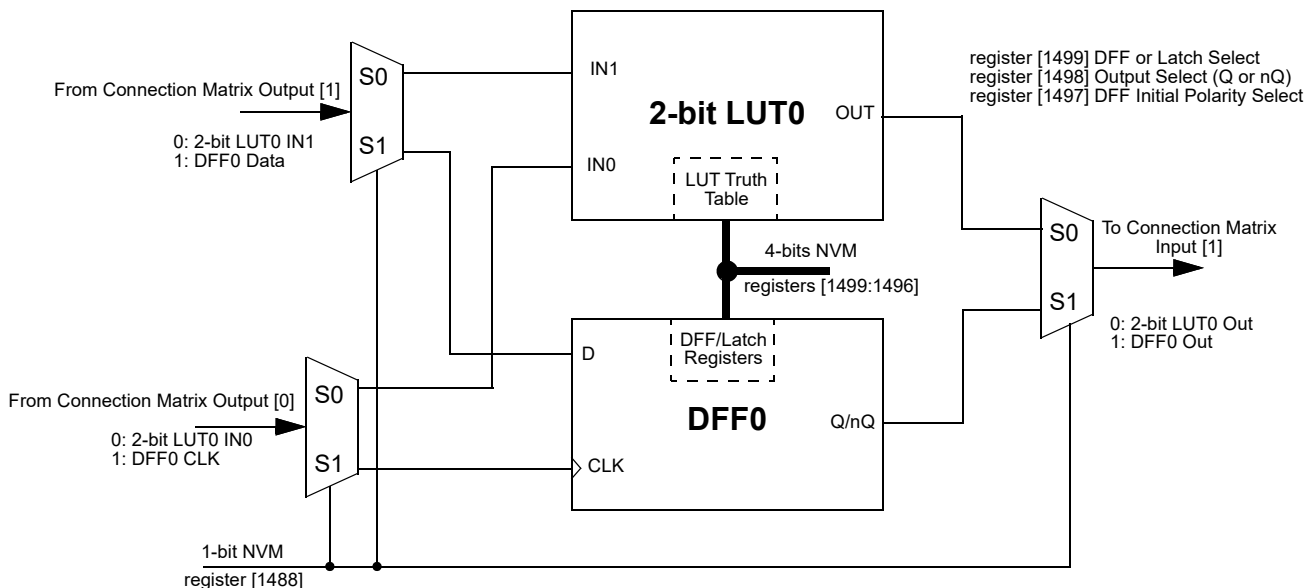

Figure 19: 2-bit LUT0 or DFF0

SLG46855-A

Auto AEC-Q100 Qualified GreenPAK Programmable Mixed-Signal Matrix

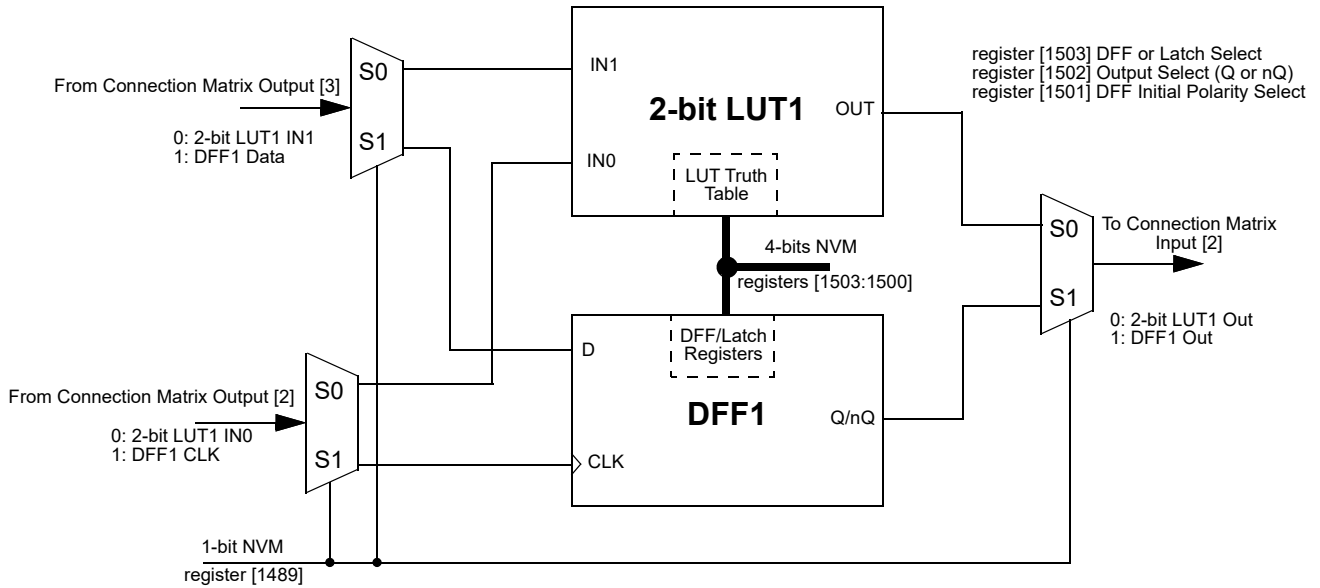

Figure 20: 2-bit LUT1 or DFF1

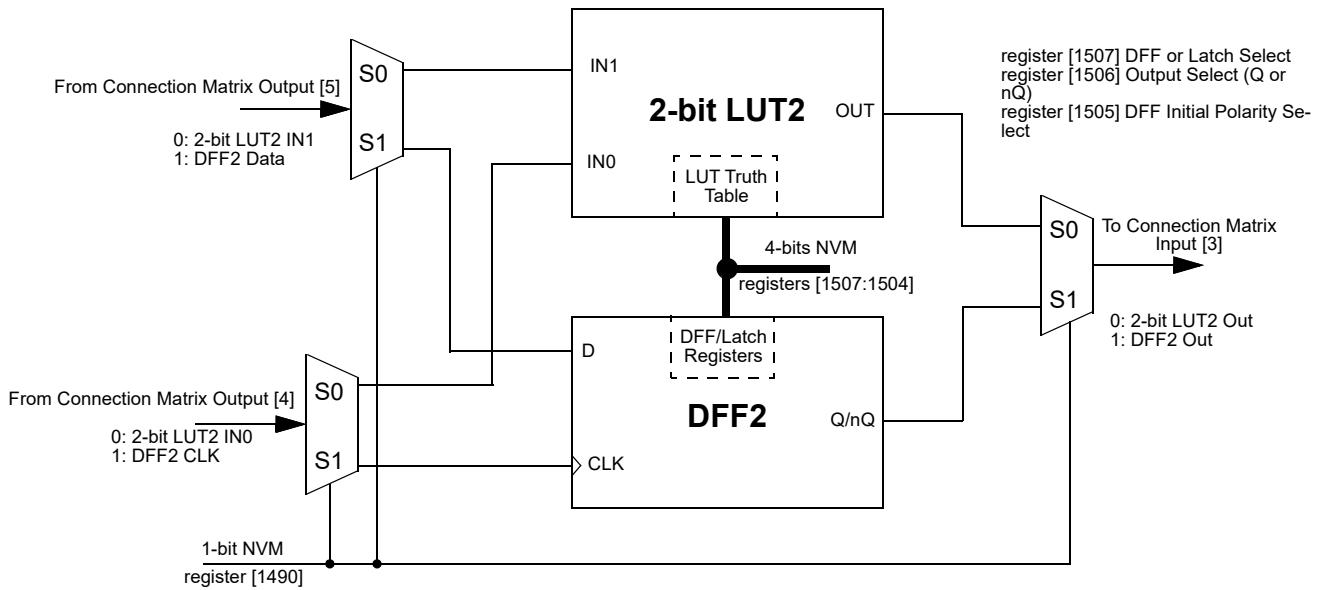

Figure 21: 2-bit LUT2 or DFF2

# SLG46855-A

## Auto AEC-Q100 Qualified GreenPAK Programmable Mixed-Signal Matrix

### 7.1.1 2-Bit LUT or D Flip-Flop Macrocell Used as 2-Bit LUT

**Table 26: 2-bit LUT0 Truth Table**

| IN1 | IN0 | OUT             |     |
|-----|-----|-----------------|-----|
| 0   | 0   | register [1496] | LSB |
| 0   | 1   | register [1497] |     |
| 1   | 0   | register [1498] |     |
| 1   | 1   | register [1499] | MSB |

**Table 27: 2-bit LUT1 Truth Table**

| IN1 | IN0 | OUT             |     |
|-----|-----|-----------------|-----|
| 0   | 0   | register [1500] | LSB |
| 0   | 1   | register [1501] |     |
| 1   | 0   | register [1502] |     |
| 1   | 1   | register [1503] | MSB |

**Table 28: 2-bit LUT2 Truth Table**

| IN1 | IN0 | OUT             |     |
|-----|-----|-----------------|-----|
| 0   | 0   | register [1504] | LSB |
| 0   | 1   | register [1505] |     |
| 1   | 0   | register [1506] |     |
| 1   | 1   | register [1507] | MSB |

This macrocell, when programmed for a LUT function, uses a 4-bit register to define their output function:

*2-Bit LUT0 is defined by registers [1499:1496]*

*2-Bit LUT1 is defined by registers [1503:1500]*

*2-Bit LUT2 is defined by registers [1507:1504]*

Table 28 shows the register bits for the standard digital logic devices (AND, NAND, OR, NOR, XOR, XNOR) that can be created within each of the 2-bit LUT logic cells

**Table 29: 2-bit LUT Standard Digital Functions**

| Function | MSB |   |   | LSB |
|----------|-----|---|---|-----|
| AND-2    | 1   | 0 | 0 | 0   |
| NAND-2   | 0   | 1 | 1 | 1   |
| OR-2     | 1   | 1 | 1 | 0   |
| NOR-2    | 0   | 0 | 0 | 1   |
| XOR-2    | 0   | 1 | 1 | 0   |
| XNOR-2   | 1   | 0 | 0 | 1   |

### 7.1.2 Initial Polarity Operations

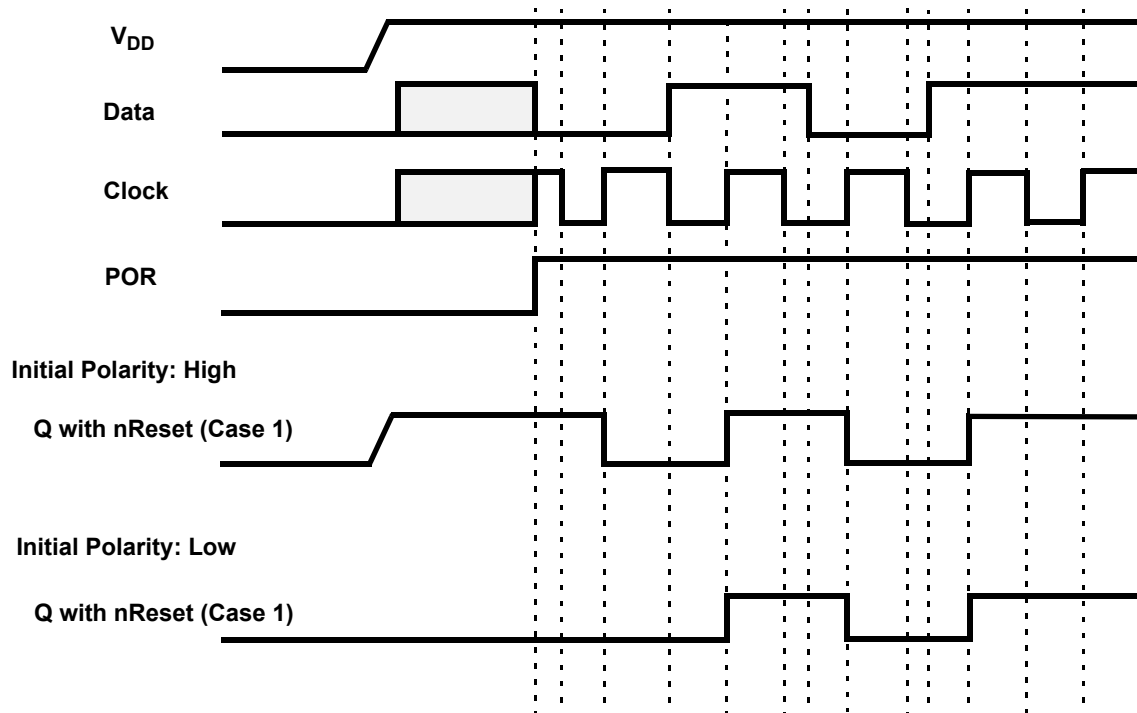

Figure 22: DFF Polarity Operations

### 7.2 2-BIT LUT OR PROGRAMMABLE PATTERN GENERATOR

The SLG46855-A has one combination function macrocell that can serve as a logic or timing function. This macrocell can serve as a Look Up Table (LUT), or Programmable Pattern Generator (PGen).

When used to implement LUT functions, the 2-bit LUT takes in two input signals from the connection matrix and produces a single output, which goes back into the connection matrix. When used as a LUT to implement combinatorial logic functions, the outputs of the LUT can be configured to any user defined function, including the following standard digital logic devices (AND, NAND, OR, NOR, XOR, XNOR). The user can also define the combinatorial relationship between inputs and outputs to be any selectable function.

It is possible to define the RST level for the PGen macrocell. There are both high level reset (RST) and a low level reset (nRST) options available, which are selected by register [1409]. When operating as a Programmable Pattern Generator, the output of the macrocell will clock out a sequence of two to sixteen bits that are user selectable in their bit values, and user selectable in the number of bits (up to sixteen) that are output before the pattern repeats.

SLG46855-A

Auto AEC-Q100 Qualified GreenPAK Programmable Mixed-Signal Matrix

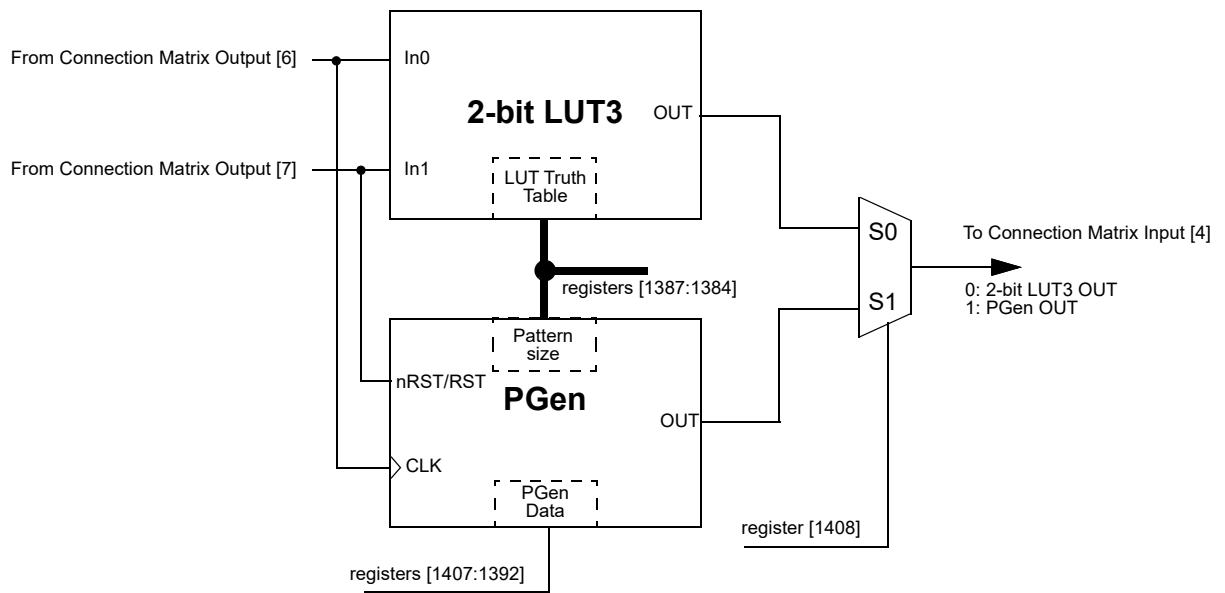

Figure 23: 2-bit LUT3 or PGen

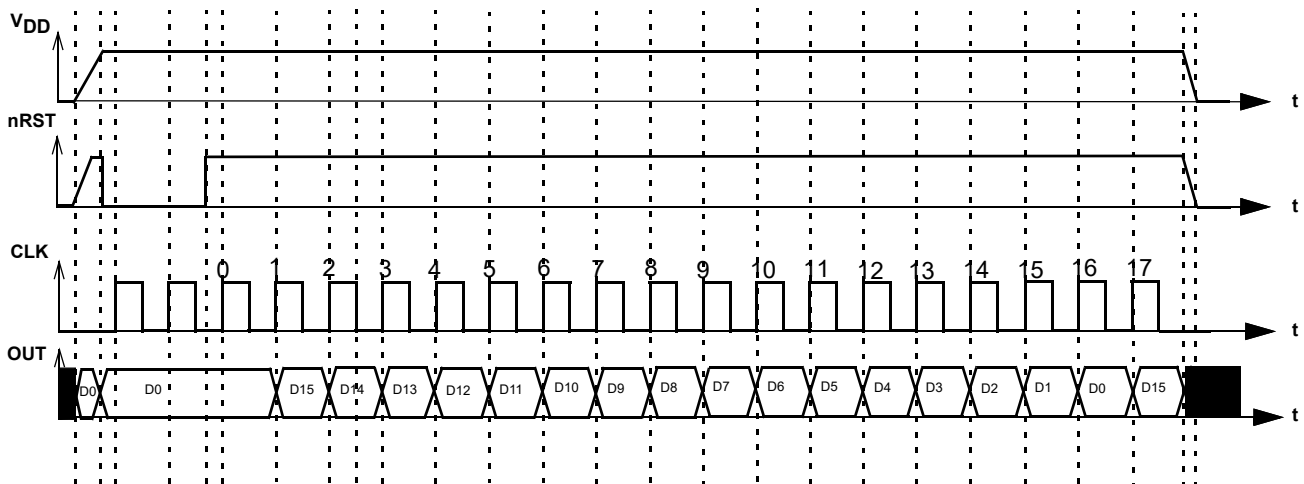

Figure 24: PGen Timing Diagram

## SLG46855-A

### Auto AEC-Q100 Qualified GreenPAK Programmable Mixed-Signal Matrix

#### 7.2.1 2-Bit LUT or PGen Macrocell Used as 2-Bit LUT

**Table 30: 2-bit LUT1 Truth Table**

| IN1 | IN0 | OUT             |     |
|-----|-----|-----------------|-----|
| 0   | 0   | register [1384] | LSB |
| 0   | 1   | register [1385] |     |
| 1   | 0   | register [1386] |     |
| 1   | 1   | register [1387] | MSB |

This macrocell, when programmed for a LUT function, uses a 4-bit register to define their output function:

*2-Bit LUT3 is defined by registers [1387:1384]*

Table 30 shows the register bits for the standard digital logic devices (AND, NAND, OR, NOR, XOR, XNOR) that can be created within each of the 2-bit LUT logic cells.

**Table 31: 2-bit LUT Standard Digital Functions**

| Function | MSB |   |   | LSB |
|----------|-----|---|---|-----|
| AND-2    | 1   | 0 | 0 | 0   |
| NAND-2   | 0   | 1 | 1 | 1   |
| OR-2     | 1   | 1 | 1 | 0   |
| NOR-2    | 0   | 0 | 0 | 1   |
| XOR-2    | 0   | 1 | 1 | 0   |
| XNOR-2   | 1   | 0 | 0 | 1   |

#### 7.3 3-BIT LUT OR D FLIP-FLOP WITH SET/RESET MACROCELLS

There are nine macrocells that can serve as either 3-bit LUTs or as D Flip-Flops with Set/Reset inputs. When used to implement LUT functions, the 3-bit LUTs each take in three input signals from the connection matrix and produce a single output, which goes back into the connection matrix. When used to implement D Flip-Flop function, the three input signals from the connection matrix go to the data (D) and clock (CLK), and Reset/Set (nRST/nSET) inputs for the Flip-Flop, with the output going back to the connection matrix. It is possible to define the active level for the reset/set input of DFF/LATCH macrocell. There are both active high level reset/set (RST/SET) and active low level reset/set (nRST/nSET) options available which are selected by register [1445].

DFF3 operation will flow the functional description below:

- If register [1443] = 0, and the CLK is rising edge triggered, then Q = D, otherwise Q will not change.
- If register [1443] = 1, then data from D is written into the DFF by the rising edge on CLK and output to Q by the falling edge on CLK.

SLG46855-A

Auto AEC-Q100 Qualified GreenPAK Programmable Mixed-Signal Matrix

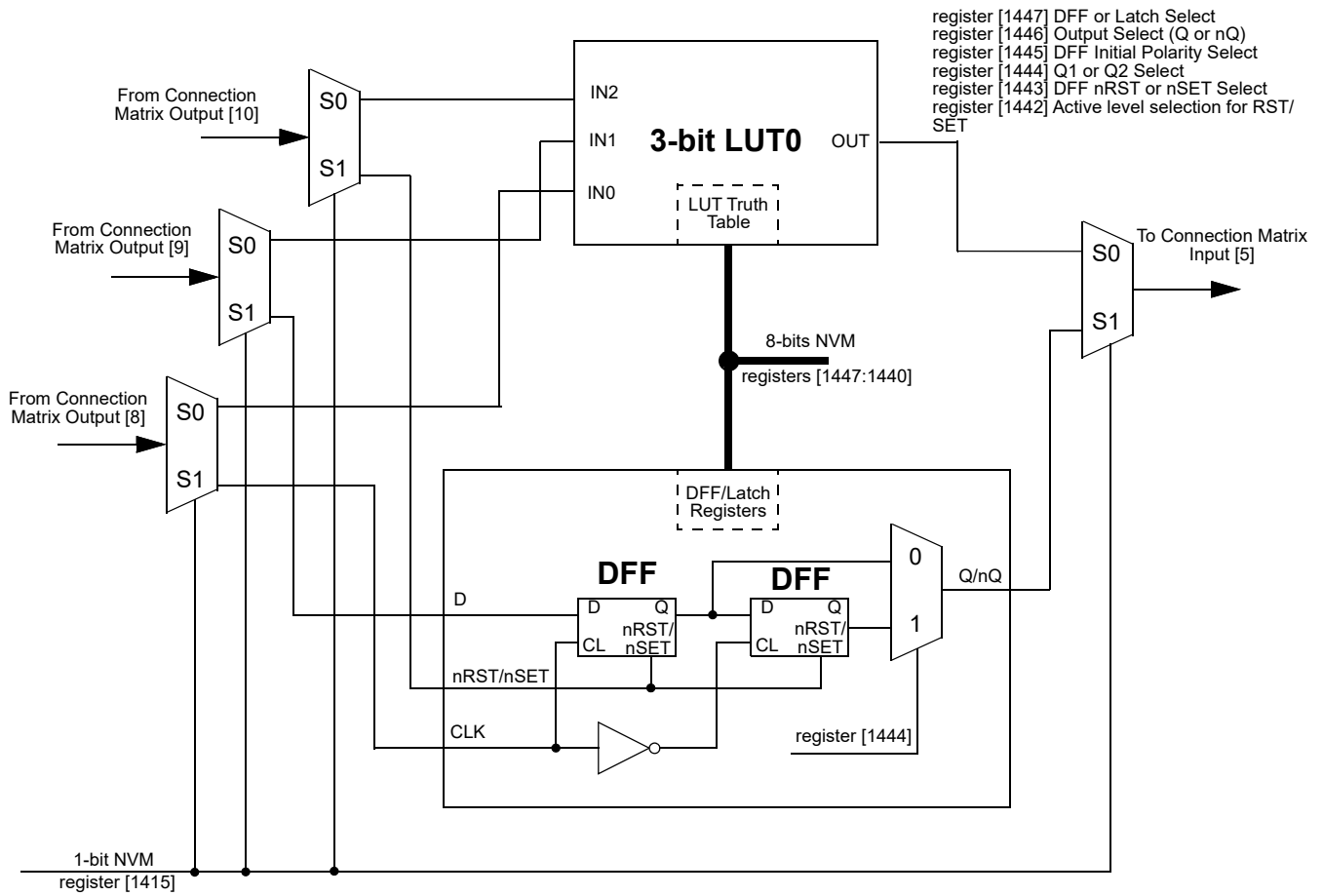

Figure 25: 3-bit LUT0 or DFF3



SLG46855-A

Auto AEC-Q100 Qualified GreenPAK Programmable Mixed-Signal Matrix

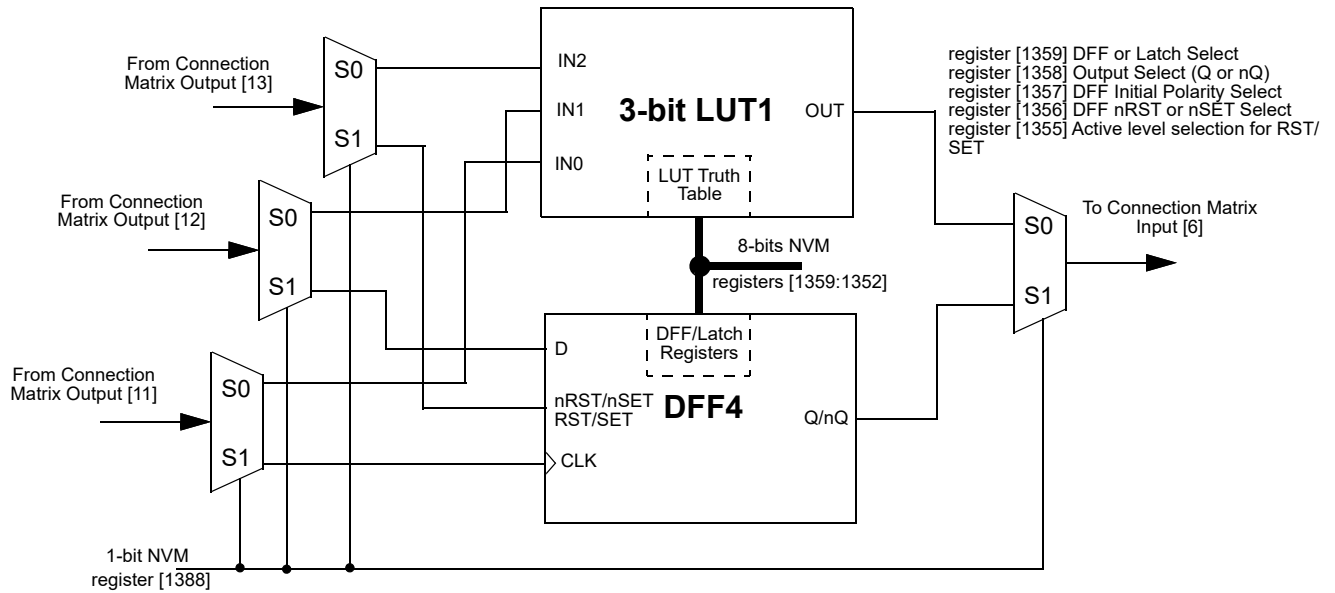

Figure 26: 3-bit LUT1 or DFF4

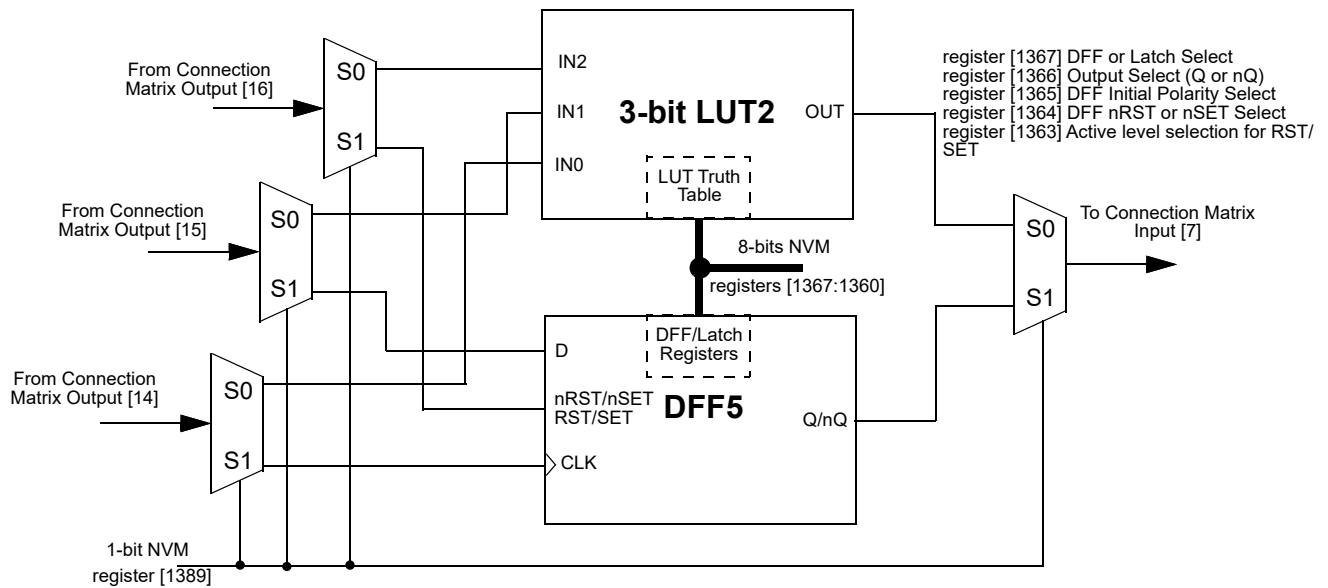

Figure 27: 3-bit LUT2 or DFF5

SLG46855-A

Auto AEC-Q100 Qualified GreenPAK Programmable Mixed-Signal Matrix

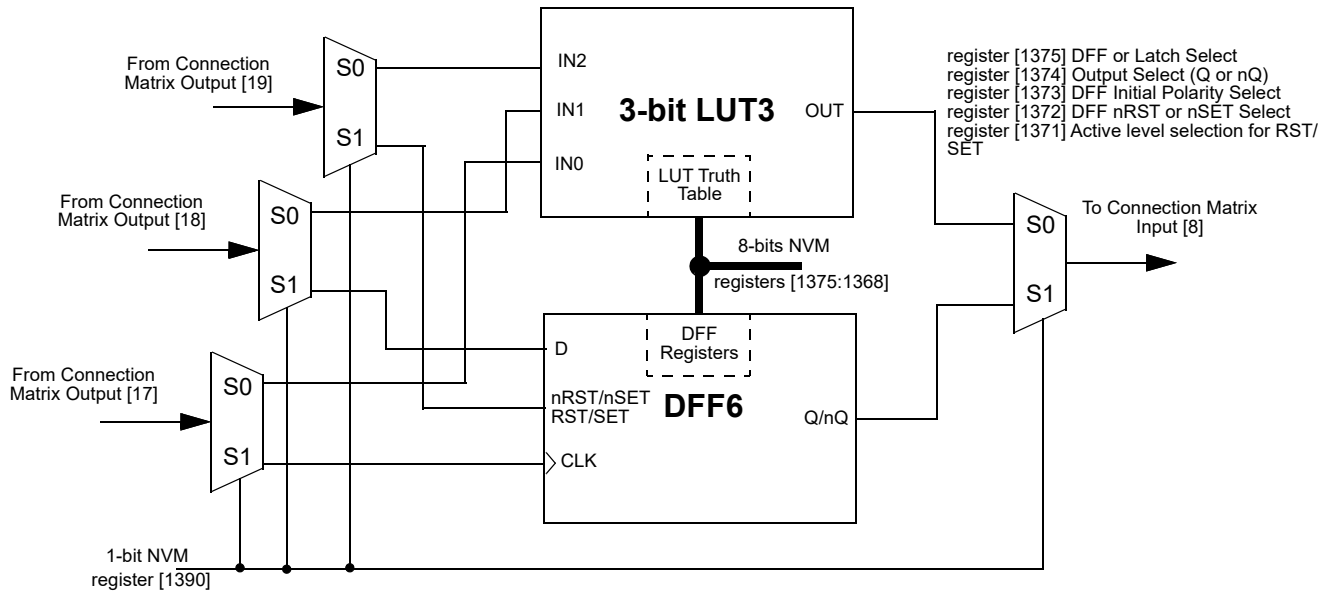

Figure 28: 3-bit LUT3 or DFF6

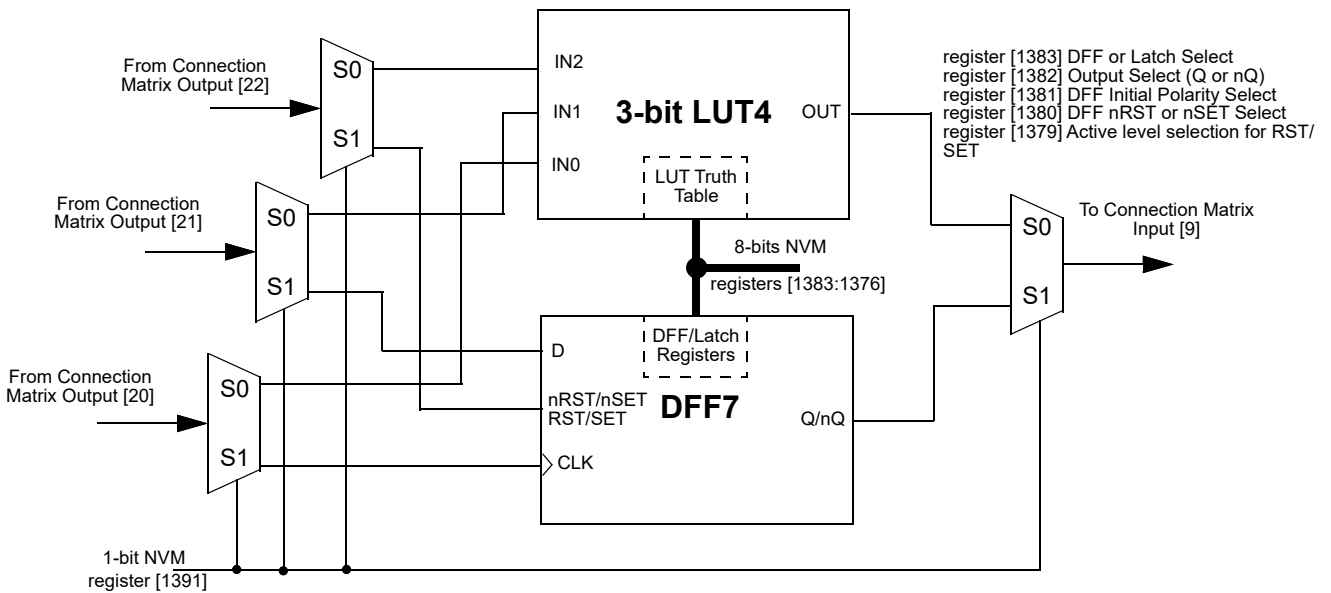

Figure 29: 3-bit LUT4 or DFF7

SLG46855-A

Auto AEC-Q100 Qualified GreenPAK Programmable Mixed-Signal Matrix

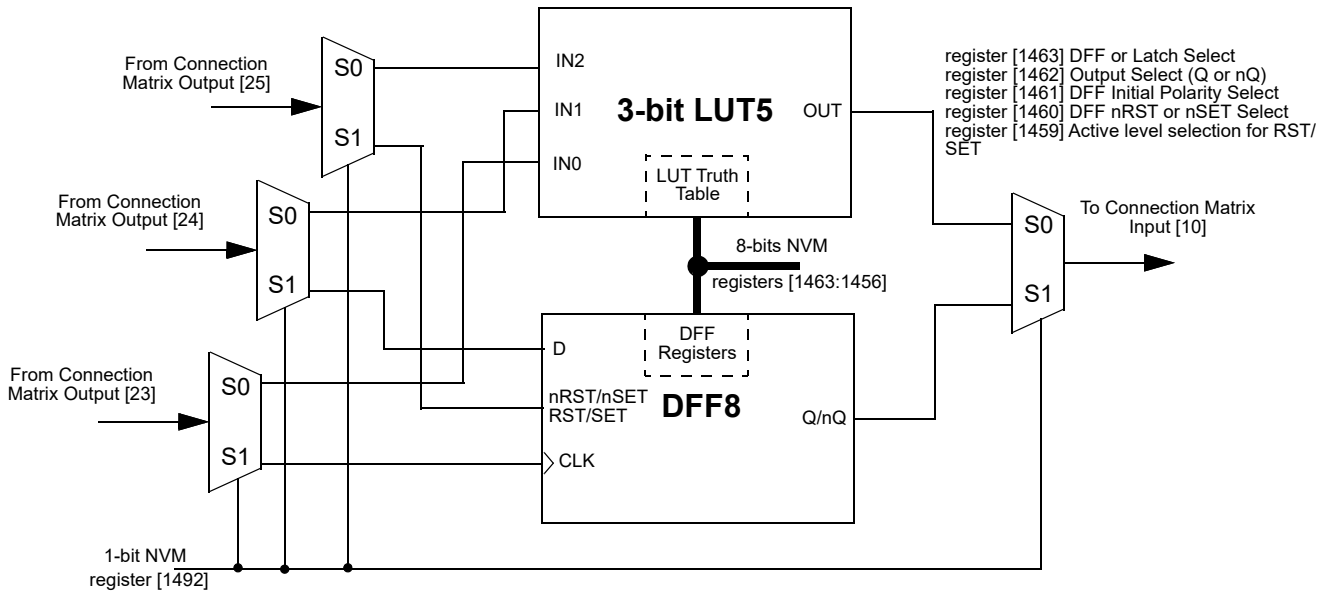

Figure 30: 3-bit LUT5 or DFF8

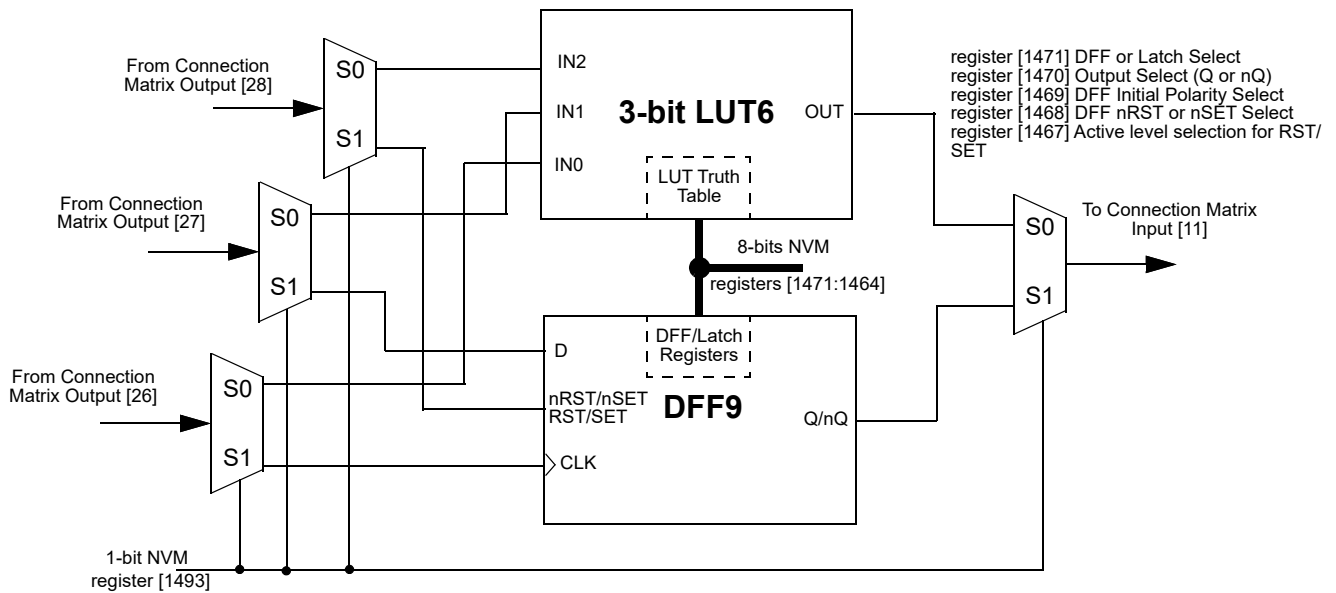

Figure 31: 3-bit LUT6 or DFF9

SLG46855-A

Auto AEC-Q100 Qualified GreenPAK Programmable Mixed-Signal Matrix

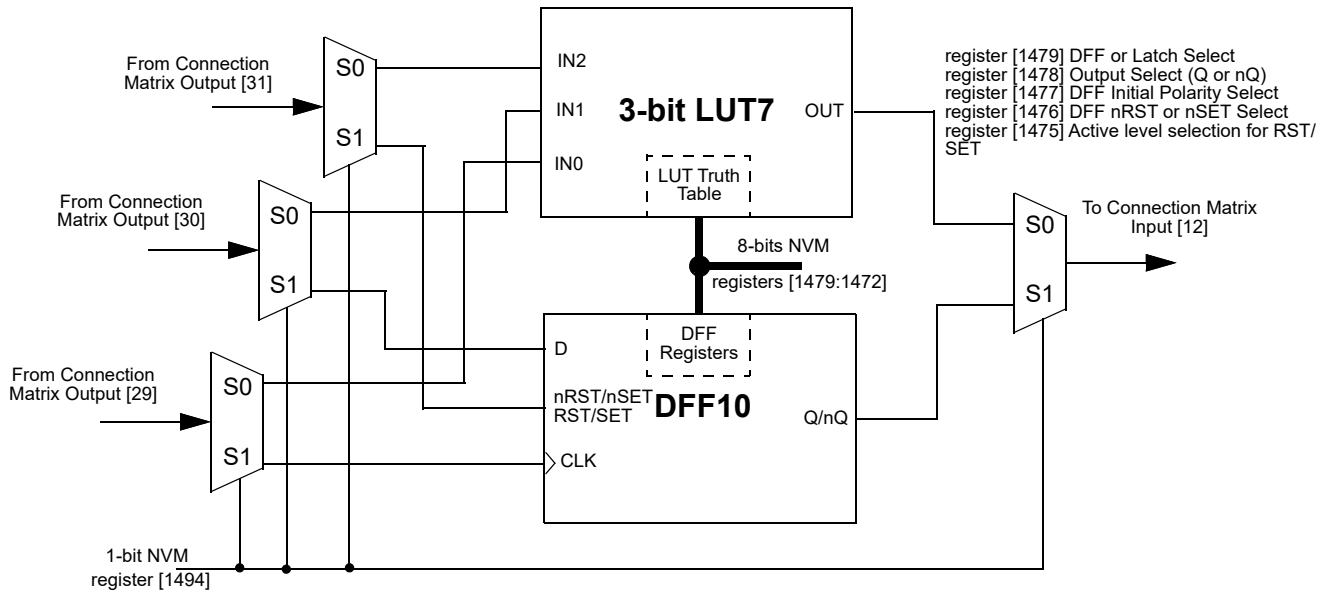

Figure 32: 3-bit LUT7 or DFF10

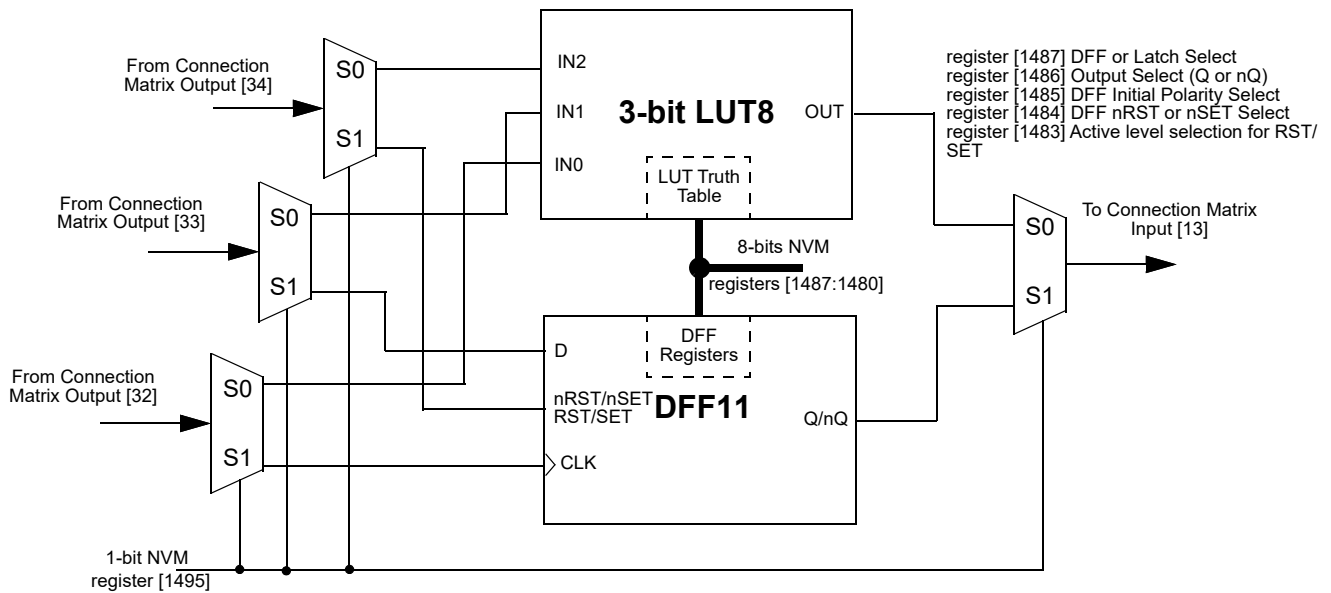

Figure 33: 3-bit LUT8 or DFF11

**Auto AEC-Q100 Qualified GreenPAK Programmable Mixed-Signal Matrix**
**7.3.1 3-Bit LUT or D Flip-Flop Macrocells Used as 3-Bit LUTs**
**Table 32: 3-bit LUT0 Truth Table**

| IN2 | IN1 | IN0 | OUT             |     |
|-----|-----|-----|-----------------|-----|
| 0   | 0   | 0   | register [1440] | LSB |
| 0   | 0   | 1   | register [1441] |     |
| 0   | 1   | 0   | register [1442] |     |
| 0   | 1   | 1   | register [1443] |     |
| 1   | 0   | 0   | register [1444] |     |
| 1   | 0   | 1   | register [1445] |     |
| 1   | 1   | 0   | register [1446] |     |
| 1   | 1   | 1   | register [1447] | MSB |

**Table 33: 3-bit LUT1 Truth Table**

| IN2 | IN1 | IN0 | OUT             |     |
|-----|-----|-----|-----------------|-----|
| 0   | 0   | 0   | register [1352] | LSB |
| 0   | 0   | 1   | register [1353] |     |
| 0   | 1   | 0   | register [1354] |     |
| 0   | 1   | 1   | register [1355] |     |
| 1   | 0   | 0   | register [1356] |     |
| 1   | 0   | 1   | register [1357] |     |
| 1   | 1   | 0   | register [1358] |     |
| 1   | 1   | 1   | register [1359] | MSB |

**Table 34: 3-bit LUT2 Truth Table**

| IN2 | IN1 | IN0 | OUT             |     |
|-----|-----|-----|-----------------|-----|
| 0   | 0   | 0   | register [1360] | LSB |
| 0   | 0   | 1   | register [1361] |     |
| 0   | 1   | 0   | register [1362] |     |
| 0   | 1   | 1   | register [1363] |     |
| 1   | 0   | 0   | register [1364] |     |
| 1   | 0   | 1   | register [1365] |     |
| 1   | 1   | 0   | register [1366] |     |
| 1   | 1   | 1   | register [1367] | MSB |

**Table 35: 3-bit LUT3 Truth Table**

| IN2 | IN1 | IN0 | OUT             |     |
|-----|-----|-----|-----------------|-----|
| 0   | 0   | 0   | register [1368] | LSB |
| 0   | 0   | 1   | register [1369] |     |
| 0   | 1   | 0   | register [1370] |     |
| 0   | 1   | 1   | register [1371] |     |
| 1   | 0   | 0   | register [1372] |     |
| 1   | 0   | 1   | register [1373] |     |
| 1   | 1   | 0   | register [1374] |     |
| 1   | 1   | 1   | register [1375] | MSB |

**Table 36: 3-bit LUT4 Truth Table**

| IN2 | IN1 | IN0 | OUT             |     |
|-----|-----|-----|-----------------|-----|
| 0   | 0   | 0   | register [1376] | LSB |
| 0   | 0   | 1   | register [1377] |     |
| 0   | 1   | 0   | register [1378] |     |
| 0   | 1   | 1   | register [1379] |     |
| 1   | 0   | 0   | register [1380] |     |
| 1   | 0   | 1   | register [1381] |     |
| 1   | 1   | 0   | register [1382] |     |
| 1   | 1   | 1   | register [1383] | MSB |

**Table 37: 3-bit LUT5 Truth Table**

| IN2 | IN1 | IN0 | OUT             |     |
|-----|-----|-----|-----------------|-----|
| 0   | 0   | 0   | register [1356] | LSB |
| 0   | 0   | 1   | register [1357] |     |
| 0   | 1   | 0   | register [1358] |     |
| 0   | 1   | 1   | register [1359] |     |
| 1   | 0   | 0   | register [1360] |     |
| 1   | 0   | 1   | register [1361] |     |
| 1   | 1   | 0   | register [1362] |     |
| 1   | 1   | 1   | register [1363] | MSB |

**Table 38: 3-bit LUT6 Truth Table**

| IN2 | IN1 | IN0 | OUT             |     |
|-----|-----|-----|-----------------|-----|
| 0   | 0   | 0   | register [1364] | LSB |
| 0   | 0   | 1   | register [1365] |     |
| 0   | 1   | 0   | register [1366] |     |
| 0   | 1   | 1   | register [1367] |     |
| 1   | 0   | 0   | register [1368] |     |
| 1   | 0   | 1   | register [1369] |     |
| 1   | 1   | 0   | register [1370] |     |
| 1   | 1   | 1   | register [1371] | MSB |

**Table 39: 3-bit LUT7 Truth Table**

| IN2 | IN1 | IN0 | OUT             |     |
|-----|-----|-----|-----------------|-----|
| 0   | 0   | 0   | register [1472] | LSB |
| 0   | 0   | 1   | register [1473] |     |
| 0   | 1   | 0   | register [1474] |     |
| 0   | 1   | 1   | register [1475] |     |
| 1   | 0   | 0   | register [1476] |     |
| 1   | 0   | 1   | register [1477] |     |
| 1   | 1   | 0   | register [1478] |     |
| 1   | 1   | 1   | register [1479] | MSB |

**Auto AEC-Q100 Qualified GreenPAK Programmable Mixed-Signal Matrix**
**Table 40: 3-bit LUT8 Truth Table**

| IN2 | IN1 | IN0 | OUT             |     |
|-----|-----|-----|-----------------|-----|
| 0   | 0   | 0   | register [1480] | LSB |
| 0   | 0   | 1   | register [1481] |     |
| 0   | 1   | 0   | register [1482] |     |
| 0   | 1   | 1   | register [1483] |     |
| 1   | 0   | 0   | register [1484] |     |
| 1   | 0   | 1   | register [1485] |     |
| 1   | 1   | 0   | register [1486] |     |
| 1   | 1   | 1   | register [1487] | MSB |

Each macrocell, when programmed for a LUT function, uses a 8-bit register to define their output function:

*3-Bit LUT0 is defined by registers [1447:1440]*

*3-Bit LUT1 is defined by registers [1359:1352]*

*3-Bit LUT2 is defined by registers [1367:1360]*

*3-Bit LUT3 is defined by registers [1375:1368]*

*3-Bit LUT4 is defined by registers [1383:1376]*

*3-Bit LUT5 is defined by registers [1463:1456]*

*3-Bit LUT6 is defined by registers [1471:1464]*

*3-Bit LUT7 is defined by registers [1479:1472]*

*3-Bit LUT8 is defined by registers [1487:1480]*

Table 40 shows the register bits for the standard digital logic devices (AND, NAND, OR, NOR, XOR, XNOR) that can be created within each of the four 3-bit LUT logic cells.

**Table 41: 3-bit LUT Standard Digital Functions**

| Function | MSB |   |   |   |   |   |   | LSB |
|----------|-----|---|---|---|---|---|---|-----|
| AND-3    | 1   | 0 | 0 | 0 | 0 | 0 | 0 | 0   |
| NAND-3   | 0   | 1 | 1 | 1 | 1 | 1 | 1 | 1   |
| OR-3     | 1   | 1 | 1 | 1 | 1 | 1 | 1 | 0   |
| NOR-3    | 0   | 0 | 0 | 0 | 0 | 0 | 0 | 1   |
| XOR-3    | 1   | 0 | 0 | 1 | 0 | 1 | 1 | 0   |
| XNOR-3   | 0   | 1 | 1 | 0 | 1 | 0 | 0 | 1   |

SLG46855-A

Auto AEC-Q100 Qualified GreenPAK Programmable Mixed-Signal Matrix

7.3.2 Initial Polarity Operations

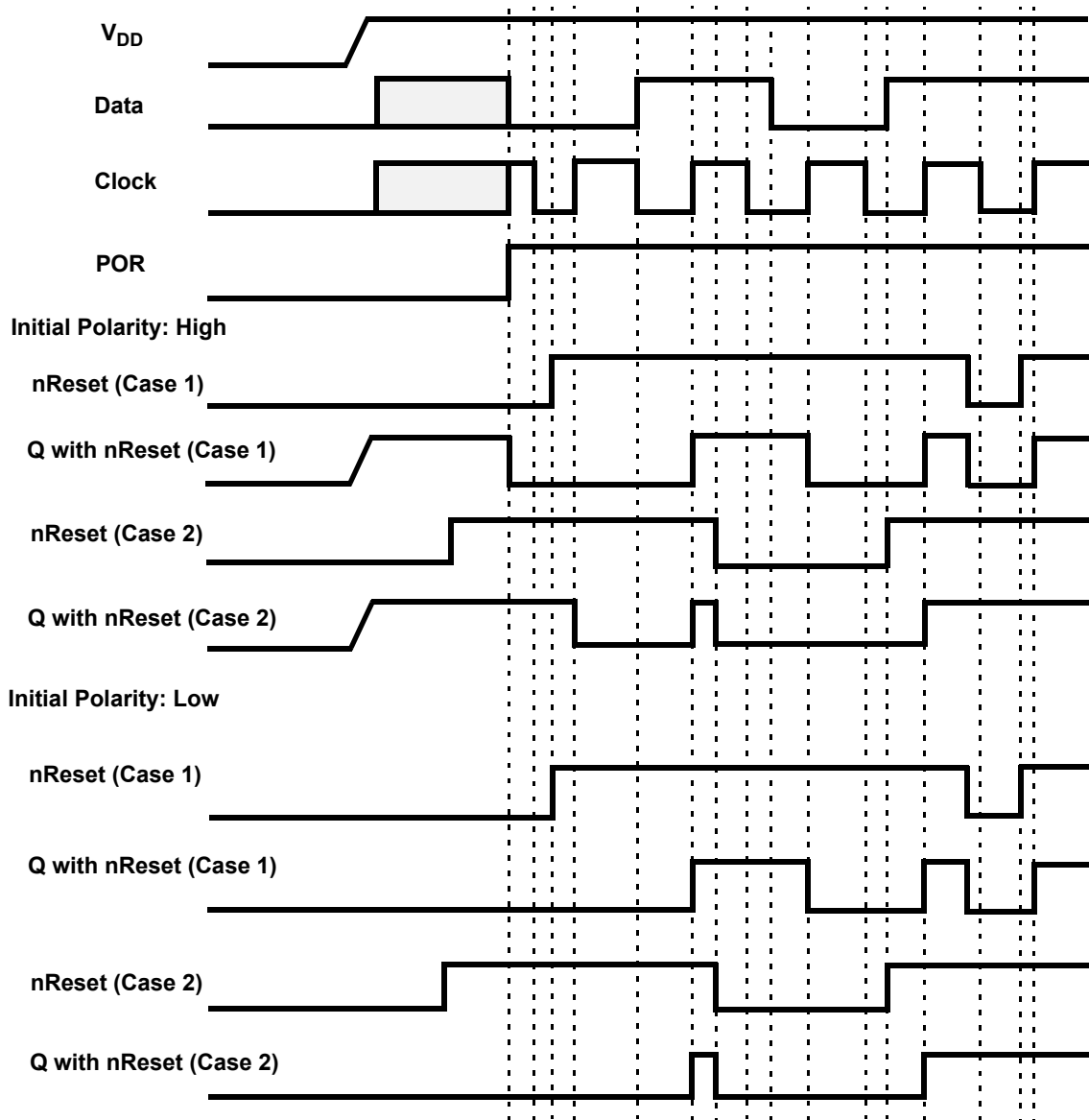
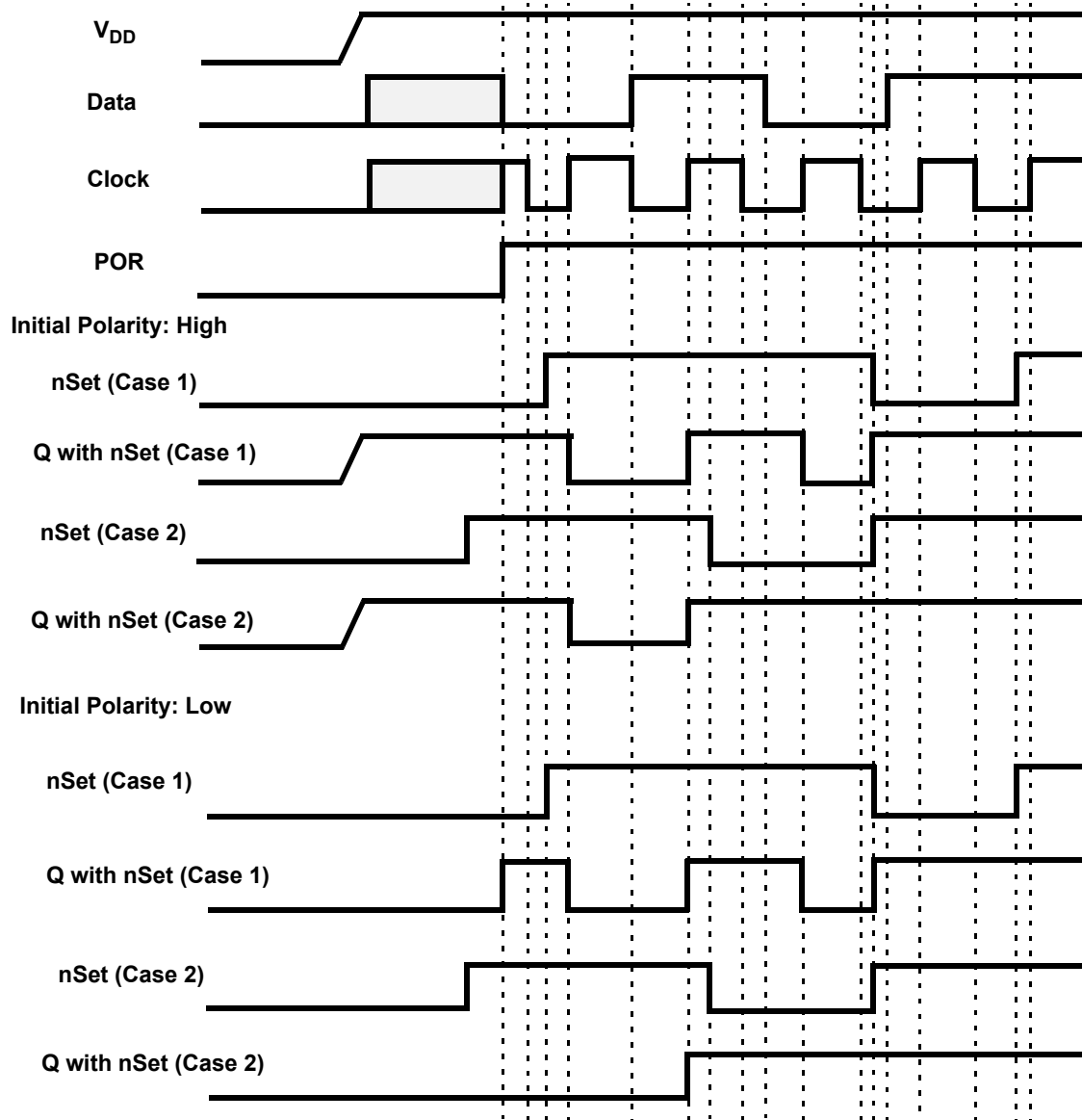

Figure 34: DFF Polarity Operations with nReset



**Figure 35: DFF Polarity Operations with nSet**

#### 7.4 4-BIT LUT OR D FLIP-FLOP WITH SET/RESET MACROCELL

There is one macrocell that can serve as either a 4-bit LUT or as a D Flip-Flop with Set/Reset inputs. When used to implement LUT functions, the 4-bit LUT takes in four input signals from the connection matrix and produce a single output, which goes back into the connection matrix. When used to implement D Flip-Flop function, the input signals from the connection matrix go to the data (D) and clock (CLK), and Reset/Set (nRST/nSET) inputs for the Flip-Flop, with the output going back to the connection matrix.

- If register [1436] = 0, and the CLK is rising edge triggered, then Q = D, otherwise Q will not change.
- If register [1436] = 1, then data from D is written into the DFF by the rising edge on CLK and output to Q by the falling edge on CLK.

It is possible to define the active level for the reset/set input of DFF/LATCH macrocell. There are both active high level reset/set (RST/SET) and active low level reset/set (nRST/nSET) options available which are selected by register [1434].



SLG46855-A

Auto AEC-Q100 Qualified GreenPAK Programmable Mixed-Signal Matrix

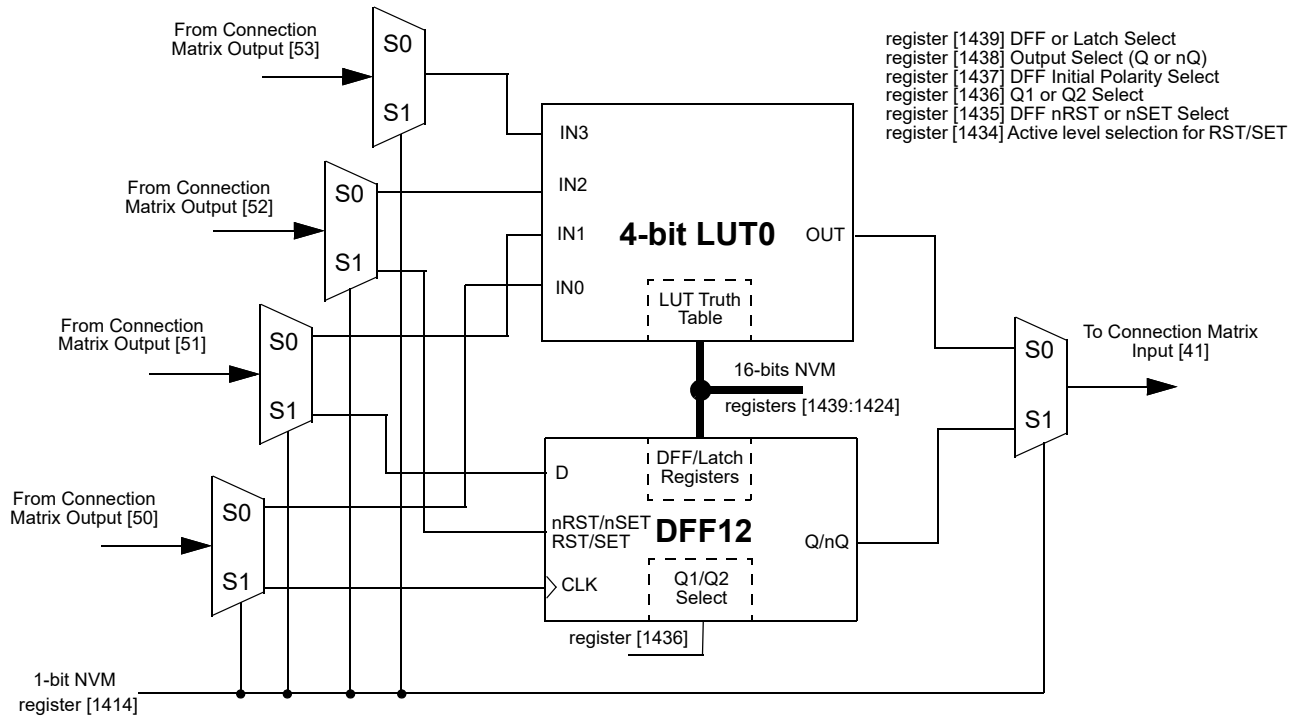

Figure 36: 4-bit LUT0 or DFF12

7.4.1 4-Bit LUT Macrocell Used as 4-Bit LUT

Table 42: 4-bit LUT0 Truth Table

| IN3 | IN2 | IN1 | IN0 | OUT             |     |
|-----|-----|-----|-----|-----------------|-----|
| 0   | 0   | 0   | 0   | register [1424] | LSB |
| 0   | 0   | 0   | 1   | register [1425] |     |
| 0   | 0   | 1   | 0   | register [1426] |     |
| 0   | 0   | 1   | 1   | register [1427] |     |
| 0   | 1   | 0   | 0   | register [1428] |     |
| 0   | 1   | 0   | 1   | register [1429] |     |
| 0   | 1   | 1   | 0   | register [1430] |     |
| 0   | 1   | 1   | 1   | register [1431] |     |
| 1   | 0   | 0   | 0   | register [1432] |     |
| 1   | 0   | 0   | 1   | register [1433] |     |
| 1   | 0   | 1   | 0   | register [1434] |     |
| 1   | 0   | 1   | 1   | register [1435] |     |
| 1   | 1   | 0   | 0   | register [1436] |     |
| 1   | 1   | 0   | 1   | register [1437] |     |
| 1   | 1   | 1   | 0   | register [1438] |     |
| 1   | 1   | 1   | 1   | register [1439] | MSB |

**Auto AEC-Q100 Qualified GreenPAK Programmable Mixed-Signal Matrix**

This macrocell, when programmed for a LUT function, uses a 16-bit register to define their output function:

*4-Bit LUT0 is defined by registers [1439:1424]*

**Table 43: 4-bit LUT Standard Digital Functions**

| Function | MSB |   |   |   |   |   |   |   |   |   |   |   |   |   |   | LSB |
|----------|-----|---|---|---|---|---|---|---|---|---|---|---|---|---|---|-----|
| AND-4    | 1   | 0 | 0 | 0 | 0 | 0 | 0 | 0 | 0 | 0 | 0 | 0 | 0 | 0 | 0 | 0   |
| NAND-4   | 0   | 1 | 1 | 1 | 1 | 1 | 1 | 1 | 1 | 1 | 1 | 1 | 1 | 1 | 1 | 1   |
| OR-4     | 1   | 1 | 1 | 1 | 1 | 1 | 1 | 1 | 1 | 1 | 1 | 1 | 1 | 1 | 1 | 0   |
| NOR-4    | 0   | 0 | 0 | 0 | 0 | 0 | 0 | 0 | 0 | 0 | 0 | 0 | 0 | 0 | 0 | 1   |
| XOR-4    | 0   | 1 | 1 | 0 | 1 | 0 | 0 | 1 | 1 | 0 | 0 | 1 | 0 | 1 | 1 | 0   |
| XNOR-4   | 1   | 0 | 0 | 1 | 0 | 1 | 1 | 0 | 0 | 1 | 1 | 0 | 1 | 0 | 0 | 1   |

### 7.5 3-BIT LUT OR PIPE DELAY/RIPPLE COUNTER MACROCELL

There is one macrocell that can serve as either a 3-bit LUT or as a Pipe Delay/Ripple Counter.

When used to implement LUT functions, the 3-bit LUT takes in three input signals from the connection matrix and produces a single output, which goes back into the connection matrix.

When used as a Pipe Delay, there are three inputs signals from the matrix, Input (IN), Clock (CLK), and Reset (nRST). The Pipe Delay cell is built from 16 D Flip-Flop logic cells that provide the three delay options, two of which are user selectable. The DFF cells are tied in series where the output (Q) of each delay cell goes to the next DFF cell input (IN). Both of the two outputs (OUT0 and OUT1) provide user selectable options for 1 – 16 stages of delay. There are delay output points for each set of the OUT0 and OUT1 outputs to a 4-input mux that is controlled by registers [1419:1416] for OUT0 and registers [1423:1420] for OUT1. The 4-input mux is used to control the selection of the amount of delay.

The overall time of the delay is based on the clock used in the SLG46855-A design. Each DFF cell has a time delay of the inverse of the clock time (either external clock or the internal Oscillator within the SLG46855-A). The sum of the number of DFF cells used will be the total time delay of the Pipe Delay logic cell. OUT1 Output can be inverted (as selected by register [1413]).

In the Ripple Counter mode there are 3 options for setting which use 7 bits. There are 3 bits to set **nSET value (SV)** in range from 0 to 7. This value will be set into the Ripple Counter outputs when nSET input goes LOW. **End value (EV)** will use 3 bits for setting output code, which will be last code in the cycle. After reaching the EV, the Ripple Counter goes to the first code by the rising edge on CLK input. The **Functionality mode** option uses 1 bit. This setting defines how exactly Ripple Counter will operate.

The user can select one of the functionality modes by register: RANGE or FULL. If the RANGE option is selected, the count starts from SV. If UP input is LOW the count goes down: SV→EV→EV-1 to SV+1→SV, and others (if SV is smaller than EV), or SV→SV-1 to EV+1→EV→SV (if SV is bigger than EV). If UP input is HIGH, count starts from SV up to EV, and others.

In the FULL range configuration the Ripple Counter functions as follows. If UP input is LOW, the count starts from SV and goes down to 0. Then current counter value jumps to EV and goes down to 0, and others.

If UP input is HIGH, count goes up starting from SV. Then current counter value jumps to 0 and counts up to EV, and others. See Ripple Counter functionality example in [Figure 38](#).

Every step is executed by the rising edge on CLK input.

SLG46855-A

Auto AEC-Q100 Qualified GreenPAK Programmable Mixed-Signal Matrix

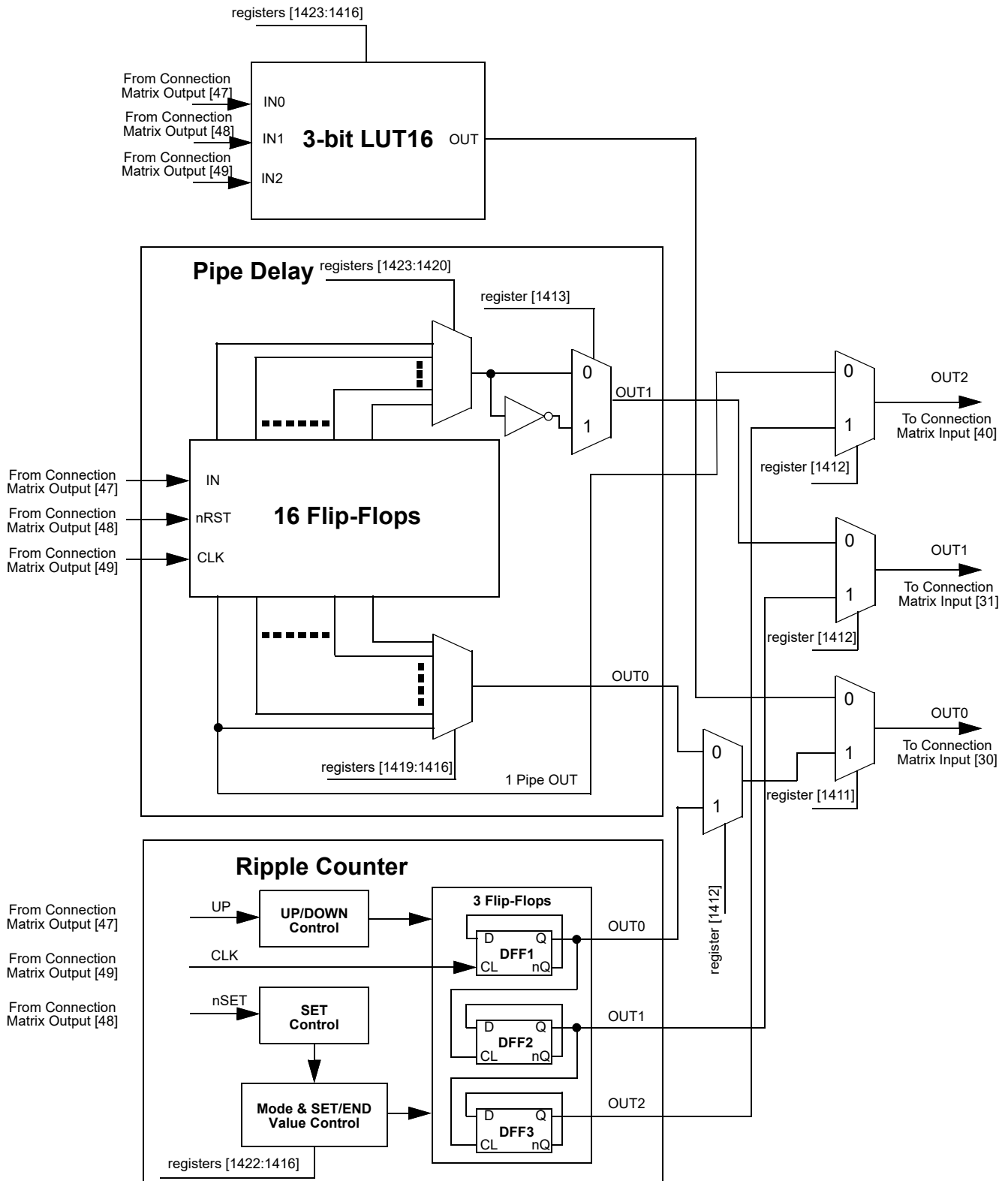

Figure 37: 3-bit LUT16/Pipe Delay/Ripple Counter

SLG46855-A

Auto AEC-Q100 Qualified GreenPAK Programmable Mixed-Signal Matrix

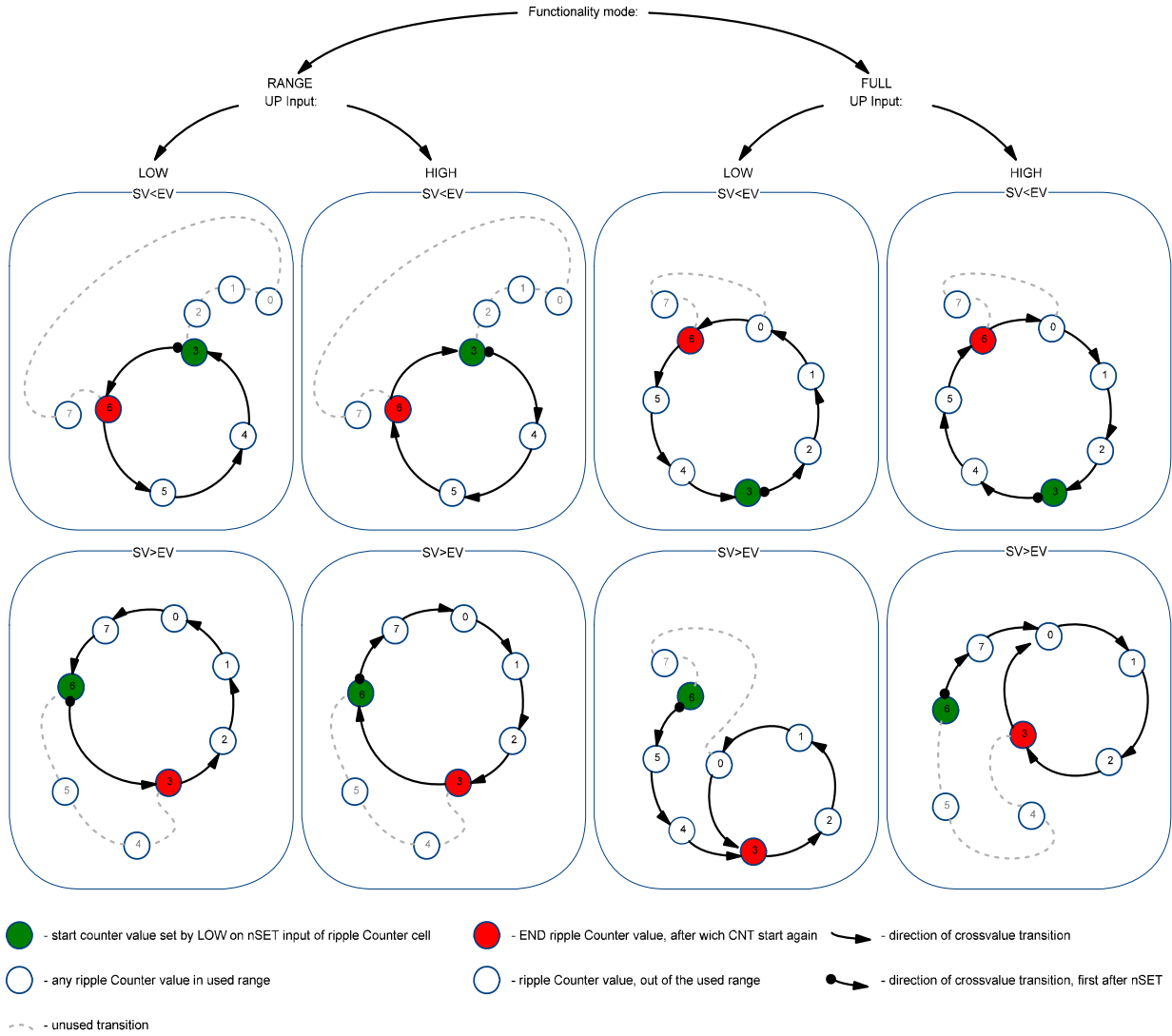

Figure 38: Example: Ripple Counter Functionality

**Auto AEC-Q100 Qualified GreenPAK Programmable Mixed-Signal Matrix**
**7.5.1 3-Bit LUT or Pipe Delay Macrocells Used as 3-Bit LUT**
**Table 44: 3-bit LUT16 Truth Table**

| IN2 | IN1 | IN0 | OUT             |
|-----|-----|-----|-----------------|
| 0   | 0   | 0   | register [1416] |
| 0   | 0   | 1   | register [1417] |
| 0   | 1   | 0   | register [1418] |
| 0   | 1   | 1   | register [1419] |
| 1   | 0   | 0   | register [1420] |
| 1   | 0   | 1   | register [1421] |
| 1   | 1   | 0   | register [1422] |
| 1   | 1   | 1   | register [1423] |

Each macrocell, when programmed for a LUT function, uses a 8-bit register to define their output function:

*3-Bit LUT16 is defined by registers [1423:1416]*

## Auto AEC-Q100 Qualified GreenPAK Programmable Mixed-Signal Matrix

### 8 Multi-Function Macrocells

The SLG46855-A has 8 Multi-Function macrocells that can serve more than one logic or timing function. In each case, they can serve as a LUT, DFF with flexible settings, or as CNT/DLY with multiple modes, such as One Shot, Frequency Detect, Edge Detect, and others. Also, the macrocell is capable to combine those functions: LUT/DFF connected to CNT/DLY or CNT/DLY connected to LUT/DFF, see [Figure 39](#).

See the list below for the functions that can be implemented in these macrocells:

- Seven macrocells that can serve as 3-bit LUTs/D Flip-Flops and as 8-Bit Counter/Delays
- One macrocell that can serve as a 4-bit LUT/D Flip-Flop and as 16-Bit Counter/Delay/FSM

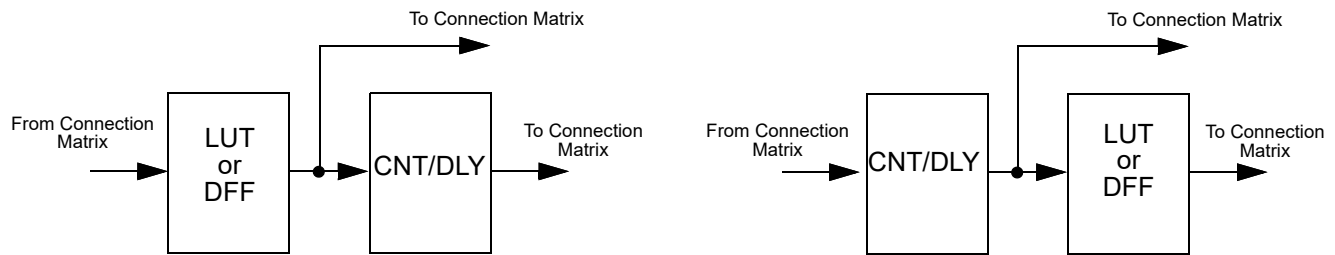

**Figure 39: Possible Connections Inside Multi-Function Macrocell**

Inputs/Outputs for the 8 Multi-Function function macrocells are configured from the connection matrix with specific logic functions being defined by the state of NVM bits.

When used as a LUT to implement combinatorial logic functions, the outputs of the LUTs can be configured to any user defined function, including the following standard digital logic devices (AND, NAND, OR, NOR, XOR, XNOR).

#### 8.1 3-BIT LUT OR DFF/LATCH WITH 8-BIT COUNTER/DELAY MACROCELLS

There are seven macrocells that can serve as 3-bit LUTs/D Flip-Flops and as 8-Bit Counter/Delays.

When used to implement LUT functions, the 3-bit LUTs each take in three input signals from the connection matrix and produce a single output, which goes back into the connection matrix or can be connected to CNT/DLY's input.

When used to implement D Flip-Flop function, the three input signals from the connection matrix go to the data (D), clock (CLK), and Reset/Set (nRST/nSET) inputs of the Flip-Flop, with the output going back to the connection matrix or to the CNT/DLY's input.

When used to implement Counter/Delays, each macrocell has a dedicated matrix input connection. For flexibility, each of these macrocells has a large selection of internal and external clock sources, as well as the option to chain from the output of the previous (N-1) CNT/DLY macrocell, to implement longer count/delay circuits. These macrocells can also operate in a One-Shot mode, which will generate an output pulse of user-defined width. They can also operate in a Frequency Detection or Edge Detection mode.

Counter/Delay macrocell has an initial value, which define its initial value after GPAK is powered up. It is possible to select initial Low or initial High, as well as initial value defined by a Delay In signal.

For example, in case initial LOW option is used, the rising edge delay will start operation.

For timing diagrams refer to sections [7.1](#) and [8.3](#).

**Note:** After two DFF – counters initialize with counter data = 0 after POR.  
 Initial state = 1 – counters initialize with counter data = 0 after POR. Initial state = 0 And After two DFF is bypass – counters initialize with counter data after POR.

SLG46855-A

Auto AEC-Q100 Qualified GreenPAK Programmable Mixed-Signal Matrix

CNT6 and CNT7 current count value can be read via I<sup>2</sup>C. However, it is possible to change the counter data (value counter starts operating from) for any macrocell using I<sup>2</sup>C write commands. In this mode, it is possible to load count data immediately (after two DFF) or after counter ends counting. See Section 15.6.1 for further details.

8.1.1 3-Bit LUT or 8-Bit CNT/DLY Block Diagrams

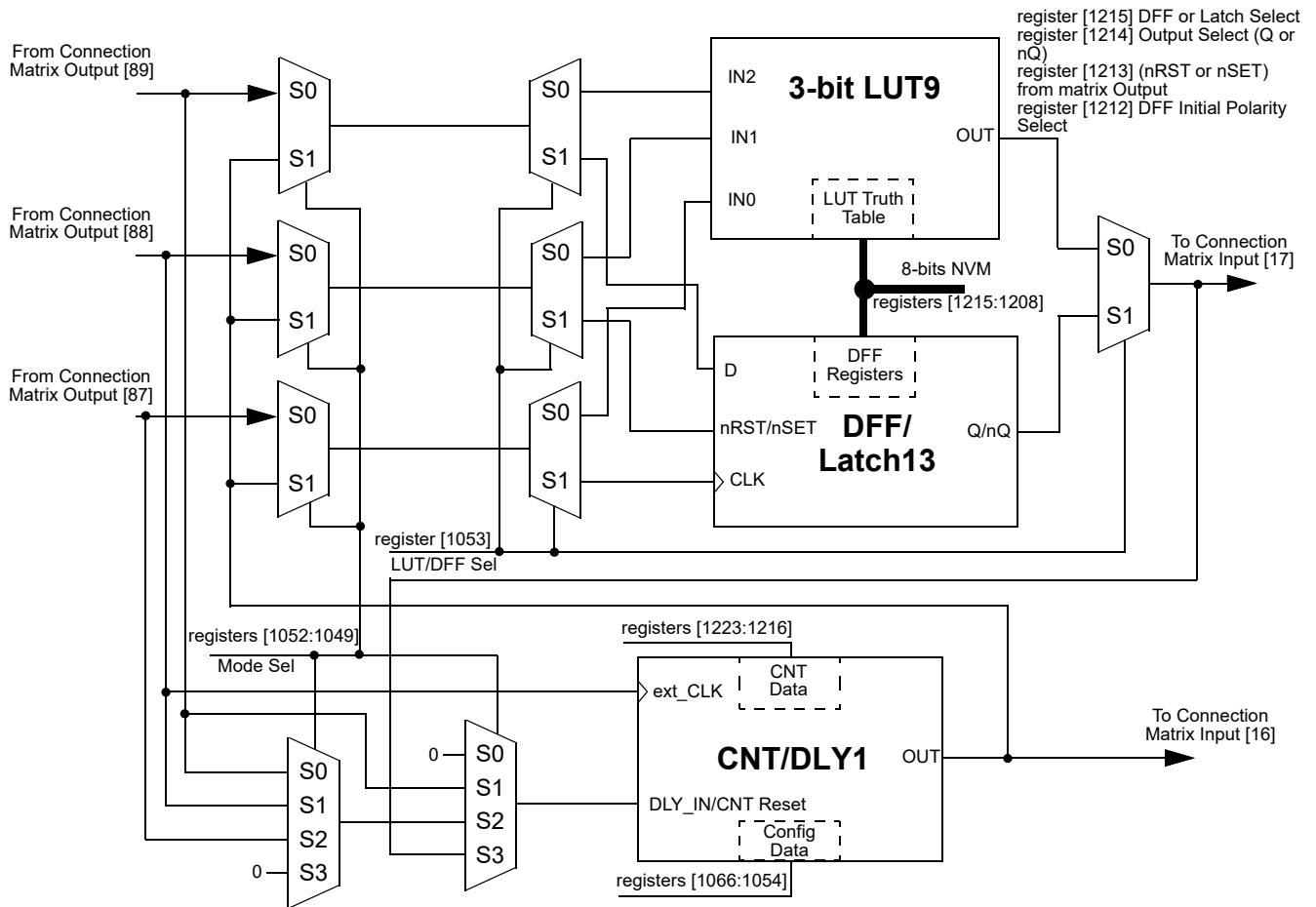

Figure 40: 8-bit Multi-Function Macrocells Block Diagram (3-bit LUT9/DFF13, CNT/DLY1)

SLG46855-A

Auto AEC-Q100 Qualified GreenPAK Programmable Mixed-Signal Matrix

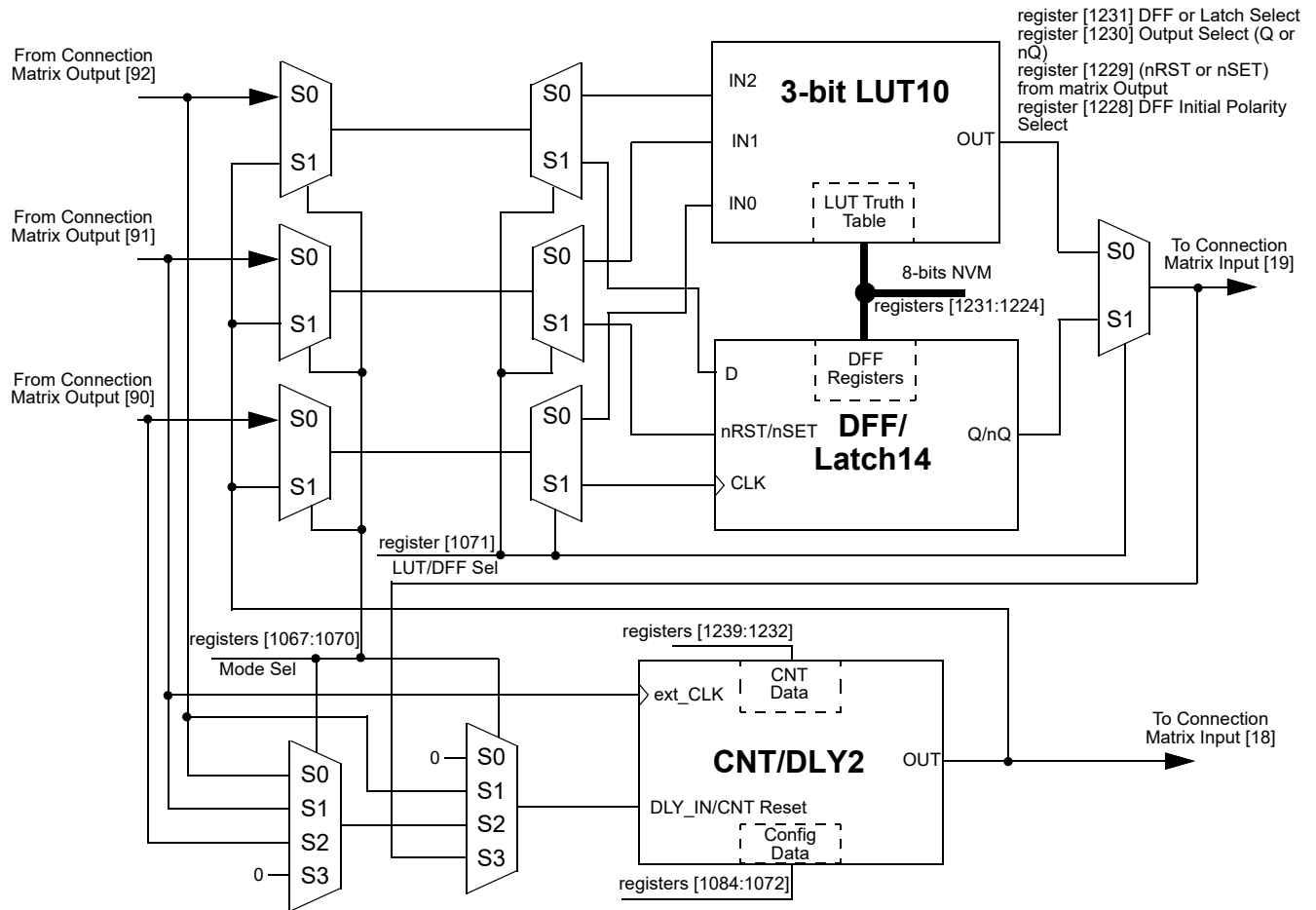

Figure 41: 8-bit Multi-Function Macrocells Block Diagram (3-bit LUT10/DFF14, CNT/DLY2)



SLG46855-A

Auto AEC-Q100 Qualified GreenPAK Programmable Mixed-Signal Matrix

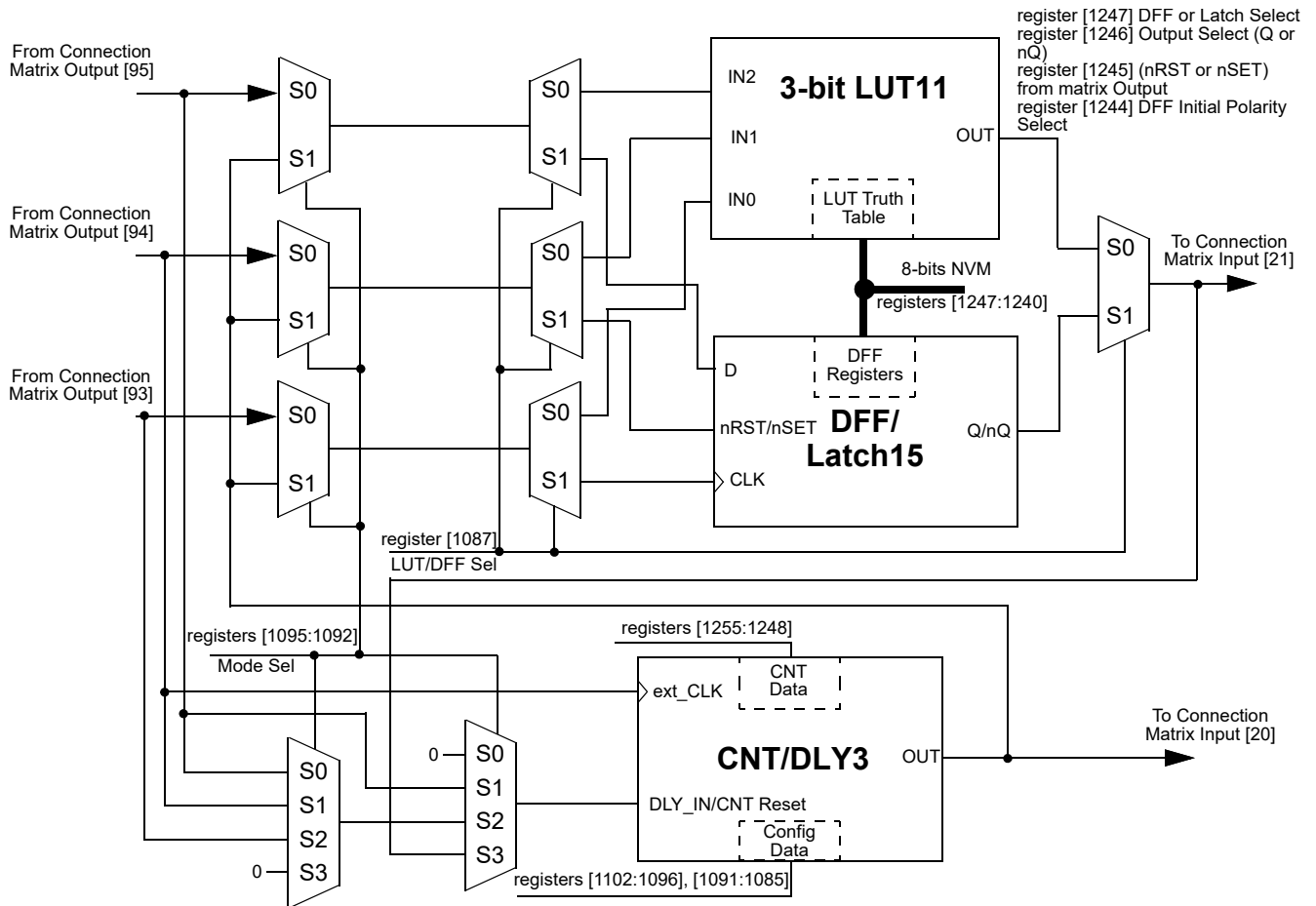

Figure 42: 8-bit Multi-Function Macrocells Block Diagram (3-bit LUT11/DFF15, CNT/DLY3)

SLG46855-A

Auto AEC-Q100 Qualified GreenPAK Programmable Mixed-Signal Matrix

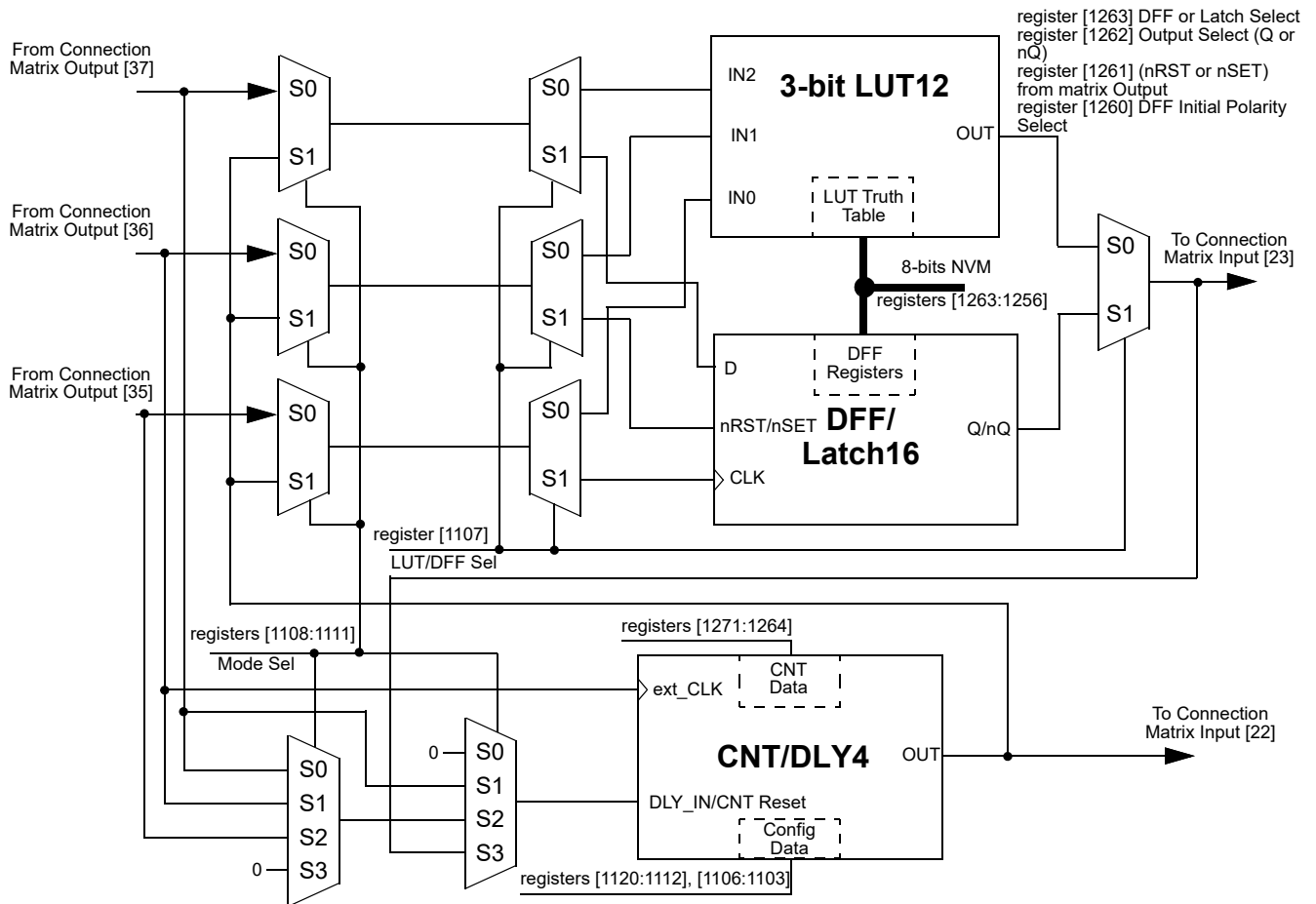

Figure 43: 8-bit Multi-Function Macrocells Block Diagram (3-bit LUT12/DFF16, CNT/DLY4)

SLG46855-A

Auto AEC-Q100 Qualified GreenPAK Programmable Mixed-Signal Matrix

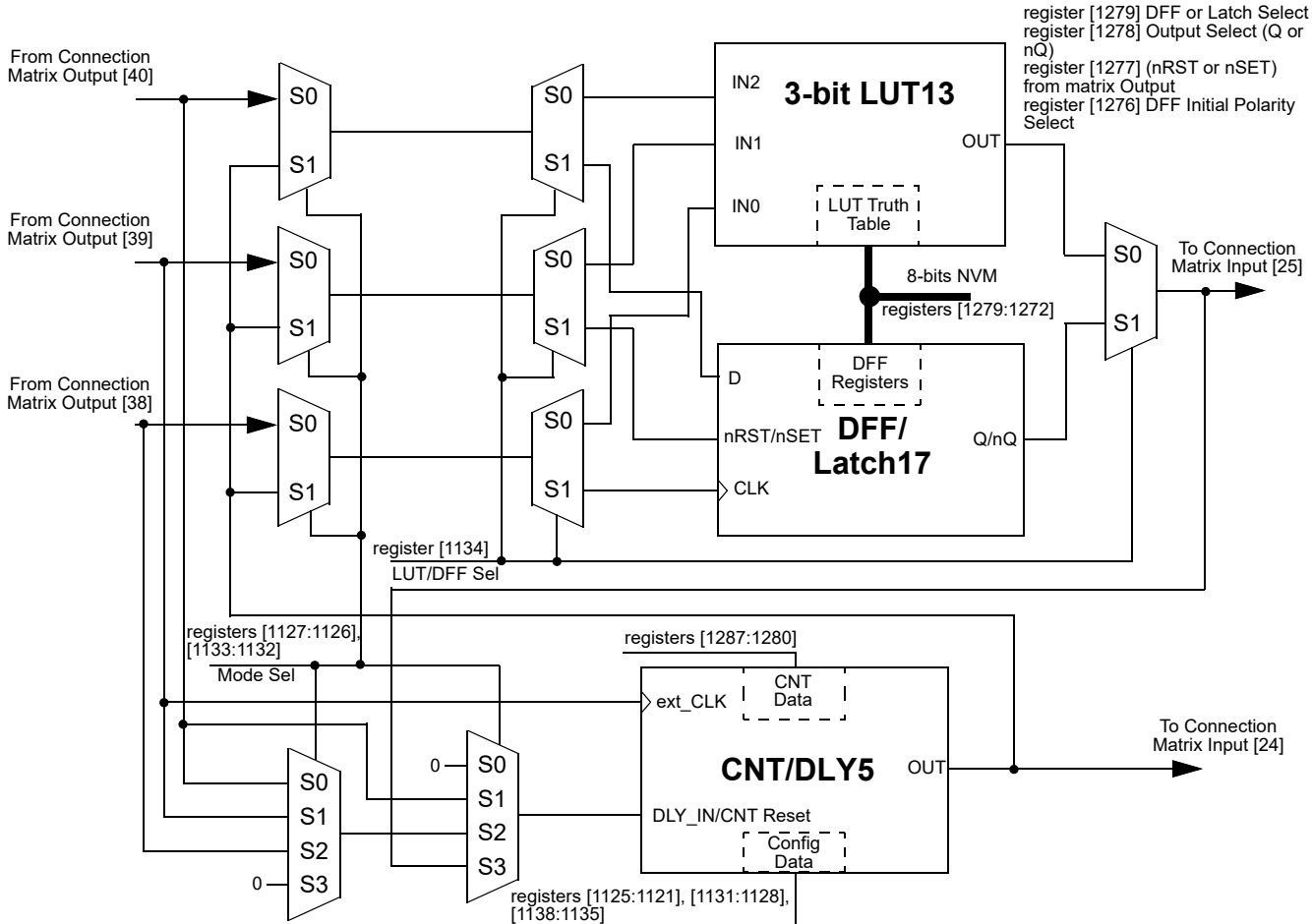

Figure 44: 8-bit Multi-Function Macrocells Block Diagram (3-bit LUT13/DFF17, CNT/DLY5)

SLG46855-A

Auto AEC-Q100 Qualified GreenPAK Programmable Mixed-Signal Matrix

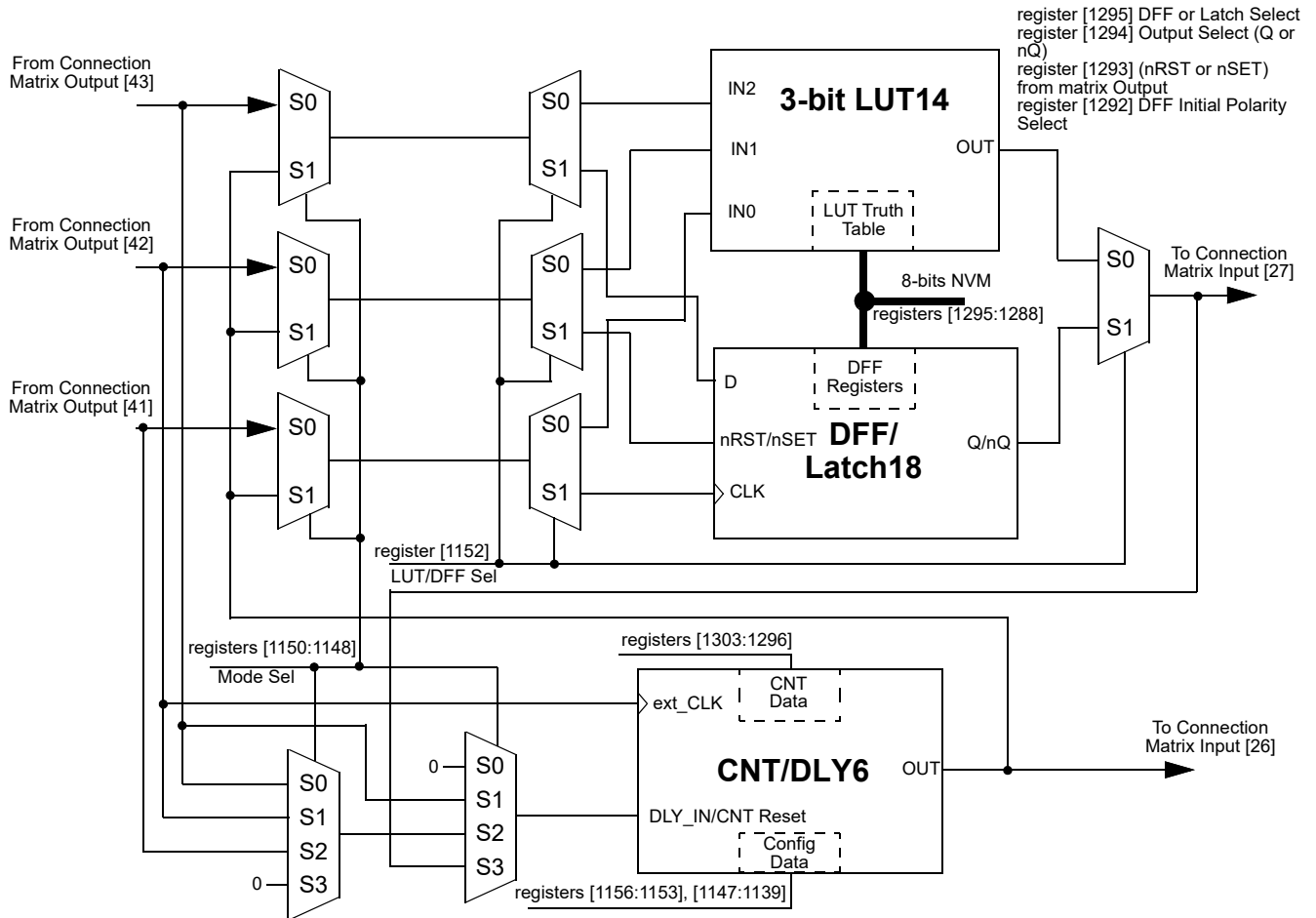

Figure 45: 8-bit Multi-Function Macrocells Block Diagram (3-bit LUT14/DFF18, CNT/DLY6)

Auto AEC-Q100 Qualified GreenPAK Programmable Mixed-Signal Matrix

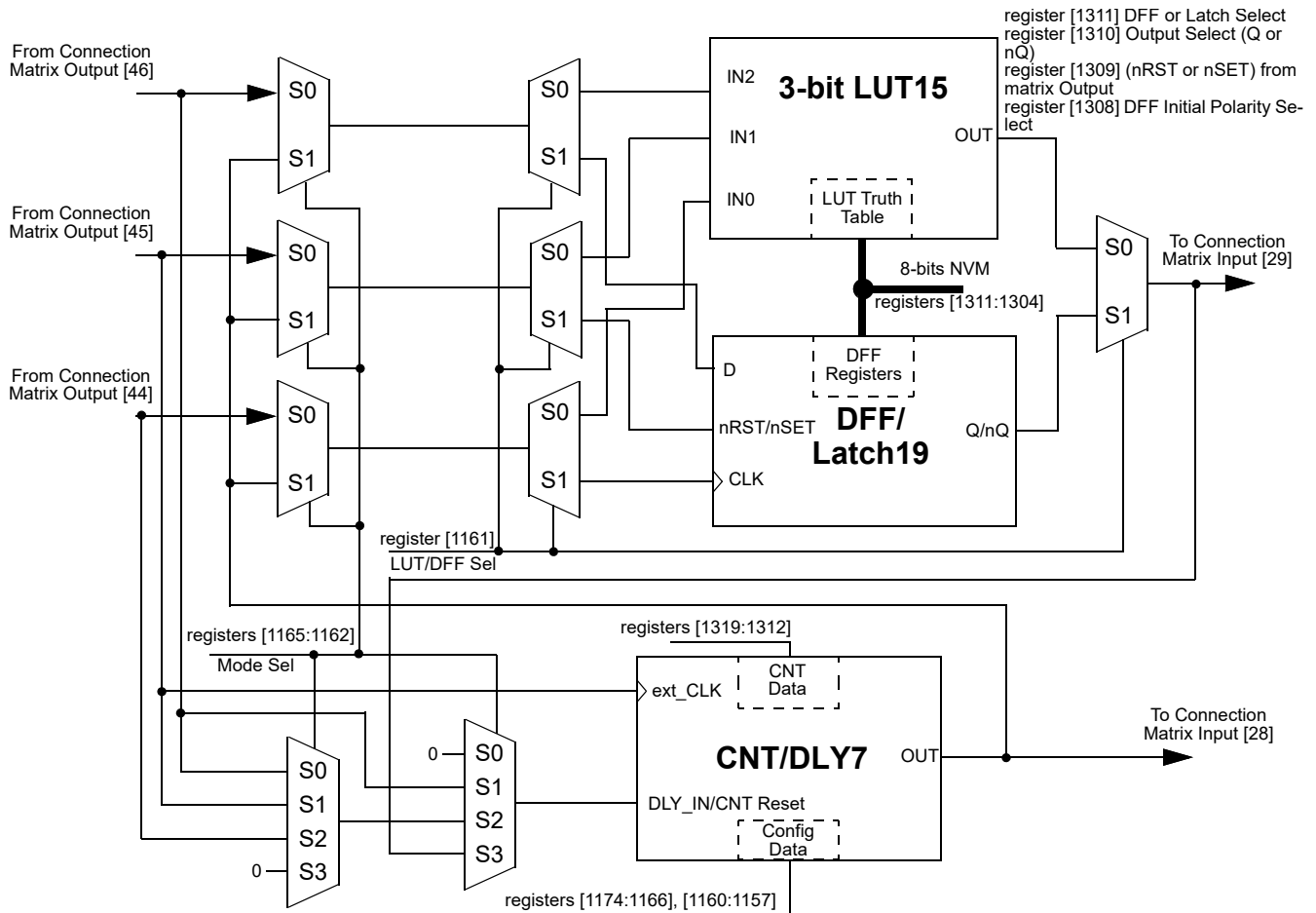

Figure 46: 8-bit Multi-Function Macrocells Block Diagram (3-bit LUT15/DFF19, CNT/DLY7)

As shown in Figures 24-30 there is a possibility to use LUT/DFF and CNT/DLY simultaneously.

**Note:** It is not possible to use LUT and DFF at once, one of these macrocells must be selected.

- Case 1. LUT/DFF in front of CNT/DLY. Three input signals from the connection matrix go to previously selected LUT or DFF's inputs and produce a single output which goes to a CNT/DLY input. In its turn Counter/Delay's output goes back to the matrix.
- Case 2. CNT/DLY in front of LUT/DFF. Two input signals from the connection matrix go to CNT/DLY's inputs (IN and CLK). Its output signal can be connected to any input of previously selected LUT or DFF, after which the signal goes back to the matrix.
- Case 3. Single LUT/DFF or CNT/DLY. Also, it is possible to use a standalone LUT/DFF or CNT/DLY. In this case, all inputs and output of the macrocell are connected to the matrix.

**Auto AEC-Q100 Qualified GreenPAK Programmable Mixed-Signal Matrix**
**8.1.2 3-Bit LUT or CNT/DLYs Used as 3-Bit LUTs**
**Table 45: 3-bit LUT9 Truth Table**

| IN2 | IN1 | IN0 | OUT             |     |
|-----|-----|-----|-----------------|-----|
| 0   | 0   | 0   | register [1208] | LSB |
| 0   | 0   | 1   | register [1209] |     |
| 0   | 1   | 0   | register [1210] |     |
| 0   | 1   | 1   | register [1211] |     |
| 1   | 0   | 0   | register [1212] |     |
| 1   | 0   | 1   | register [1213] |     |
| 1   | 1   | 0   | register [1214] |     |
| 1   | 1   | 1   | register [1215] | MSB |

**Table 46: 3-bit LUT10 Truth Table**

| IN2 | IN1 | IN0 | OUT             |     |
|-----|-----|-----|-----------------|-----|
| 0   | 0   | 0   | register [1224] | LSB |
| 0   | 0   | 1   | register [1225] |     |
| 0   | 1   | 0   | register [1226] |     |
| 0   | 1   | 1   | register [1227] |     |
| 1   | 0   | 0   | register [1228] |     |
| 1   | 0   | 1   | register [1229] |     |
| 1   | 1   | 0   | register [1230] |     |
| 1   | 1   | 1   | register [1231] | MSB |

**Table 47: 3-bit LUT11 Truth Table**

| IN2 | IN1 | IN0 | OUT             |     |
|-----|-----|-----|-----------------|-----|
| 0   | 0   | 0   | register [1240] | LSB |
| 0   | 0   | 1   | register [1241] |     |
| 0   | 1   | 0   | register [1242] |     |
| 0   | 1   | 1   | register [1243] |     |
| 1   | 0   | 0   | register [1244] |     |
| 1   | 0   | 1   | register [1245] |     |
| 1   | 1   | 0   | register [1246] |     |
| 1   | 1   | 1   | register [1247] | MSB |

**Table 48: 3-bit LUT12 Truth Table**

| IN2 | IN1 | IN0 | OUT             |     |
|-----|-----|-----|-----------------|-----|
| 0   | 0   | 0   | register [1256] | LSB |
| 0   | 0   | 1   | register [1257] |     |
| 0   | 1   | 0   | register [1258] |     |
| 0   | 1   | 1   | register [1259] |     |
| 1   | 0   | 0   | register [1260] |     |
| 1   | 0   | 1   | register [1261] |     |
| 1   | 1   | 0   | register [1262] |     |
| 1   | 1   | 1   | register [1263] | MSB |

**Table 49: 3-bit LUT13 Truth Table**

| IN2 | IN1 | IN0 | OUT             |     |
|-----|-----|-----|-----------------|-----|
| 0   | 0   | 0   | register [1272] | LSB |
| 0   | 0   | 1   | register [1273] |     |
| 0   | 1   | 0   | register [1274] |     |
| 0   | 1   | 1   | register [1275] |     |
| 1   | 0   | 0   | register [1276] |     |
| 1   | 0   | 1   | register [1277] |     |
| 1   | 1   | 0   | register [1278] |     |
| 1   | 1   | 1   | register [1279] | MSB |

**Table 50: 3-bit LUT14 Truth Table**

| IN2 | IN1 | IN0 | OUT             |     |
|-----|-----|-----|-----------------|-----|
| 0   | 0   | 0   | register [1288] | LSB |
| 0   | 0   | 1   | register [1289] |     |
| 0   | 1   | 0   | register [1290] |     |
| 0   | 1   | 1   | register [1291] |     |
| 1   | 0   | 0   | register [1292] |     |
| 1   | 0   | 1   | register [1293] |     |
| 1   | 1   | 0   | register [1294] |     |
| 1   | 1   | 1   | register [1295] | MSB |

**Table 51: 3-bit LUT15 Truth Table**

| IN2 | IN1 | IN0 | OUT             |     |
|-----|-----|-----|-----------------|-----|
| 0   | 0   | 0   | register [1304] | LSB |
| 0   | 0   | 1   | register [1305] |     |
| 0   | 1   | 0   | register [1306] |     |
| 0   | 1   | 1   | register [1307] |     |
| 1   | 0   | 0   | register [1308] |     |
| 1   | 0   | 1   | register [1309] |     |
| 1   | 1   | 0   | register [1310] |     |
| 1   | 1   | 1   | register [1311] | MSB |

## Auto AEC-Q100 Qualified GreenPAK Programmable Mixed-Signal Matrix

Each macrocell, when programmed for a LUT function, uses a 8-bit register to define their output function:

*3-Bit LUT9 is defined by registers [1215:1208]*

*3-Bit LUT10 is defined by registers [1231:1224]*

*3-Bit LUT11 is defined by registers [1247:1240]*

*3-Bit LUT12 is defined by registers [1263:1256]*

*3-Bit LUT13 is defined by registers [1279:1272]*

*3-Bit LUT14 is defined by registers [1295:1288]*

*3-Bit LUT15 is defined by registers [1311:1304]*

## Auto AEC-Q100 Qualified GreenPAK Programmable Mixed-Signal Matrix

### 8.2 4-BIT LUT OR DFF/LATCH WITH 16-BIT COUNTER/DELAY MACROCELL

There is one macrocell that can serve as either 4-bit LUT/D Flip-Flops or as 16-bit Counter/Delay.

When used to implement LUT function, the 4-bit LUT takes in four input signals from the Connection Matrix and produces a single output, which goes back into the Connection Matrix.

When used to implement D Flip-Flop function, the two input signals from the connection matrix go to the data (D) and clock (CLK) inputs for the Flip-Flop, with the output going back to the connection matrix.

When used to implement 16-Bit Counter/Delay function, two of the four input signals from the connection matrix go to the external clock (EXT\_CLK) and reset (DLY\_IN/CNT Reset) for the Counter/Delay, with the output going back to the connection matrix.

This macrocell has an optional Finite State Machine (FSM) function. There are two additional matrix inputs for Up and Keep to support FSM functionality

This macrocell can also operate in a one-shot mode, which will generate an output pulse of user-defined width.

This macrocell can also operate in a frequency detection or edge detection mode.

This macrocell can have its active count value read via I<sup>2</sup>C. See Section 15.6.1 for further details.

**Note:** After two DFF – counters initialize with counter data = 0 after POR.  
 Initial state = 1 – counters initialize with counter data = 0 after POR.  
 Initial state = 0 And After two DFF is bypass – counters initialize with counter data after POR.



SLG46855-A

Auto AEC-Q100 Qualified GreenPAK Programmable Mixed-Signal Matrix

8.2.1 4-Bit LUT or DFF/LATCH with 16-Bit CNT/DLY Block Diagram

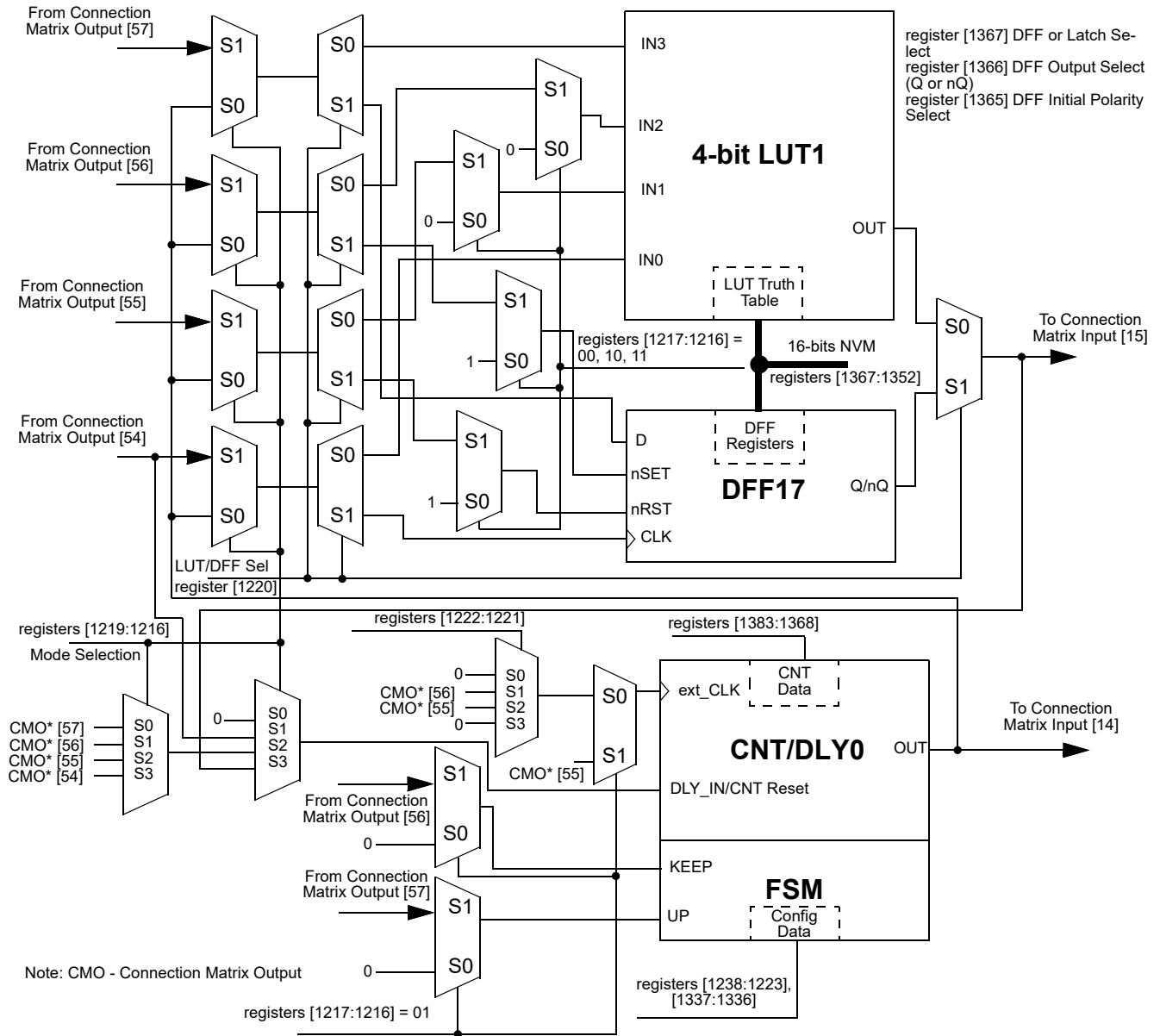

Figure 47: 4-bit LUT1 or CNT/DLY0

**Auto AEC-Q100 Qualified GreenPAK Programmable Mixed-Signal Matrix**
**8.2.2 4-Bit LUT or 16-Bit Counter/Delay Macrocells Used as 4-Bit LUTs**
**Table 52: 4-bit LUT1 Truth Table**

| IN3 | IN2 | IN1 | IN0 | OUT             |     |
|-----|-----|-----|-----|-----------------|-----|
| 0   | 0   | 0   | 0   | register [1176] | LSB |
| 0   | 0   | 0   | 1   | register [1177] |     |
| 0   | 0   | 1   | 0   | register [1178] |     |
| 0   | 0   | 1   | 1   | register [1179] |     |
| 0   | 1   | 0   | 0   | register [1180] |     |
| 0   | 1   | 0   | 1   | register [1181] |     |
| 0   | 1   | 1   | 0   | register [1182] |     |
| 0   | 1   | 1   | 1   | register [1183] |     |
| 1   | 0   | 0   | 0   | register [1184] |     |
| 1   | 0   | 0   | 1   | register [1185] |     |
| 1   | 0   | 1   | 0   | register [1186] |     |
| 1   | 0   | 1   | 1   | register [1187] |     |
| 1   | 1   | 0   | 0   | register [1188] |     |
| 1   | 1   | 0   | 1   | register [1189] |     |
| 1   | 1   | 1   | 0   | register [1190] |     |
| 1   | 1   | 1   | 1   | register [1191] | MSB |

This macrocell, when programmed for a LUT function, uses a 16-bit register to define their output function:

*4-Bit LUT1 is defined by registers [1191:1176]*

**Table 53: 4-bit LUT Standard Digital Functions**

| Function | MSB |   |   |   |   |   |   |   |   |   |   |   |   |   |   | LSB |
|----------|-----|---|---|---|---|---|---|---|---|---|---|---|---|---|---|-----|
| AND-4    | 1   | 0 | 0 | 0 | 0 | 0 | 0 | 0 | 0 | 0 | 0 | 0 | 0 | 0 | 0 | 0   |
| NAND-4   | 0   | 1 | 1 | 1 | 1 | 1 | 1 | 1 | 1 | 1 | 1 | 1 | 1 | 1 | 1 | 1   |
| OR-4     | 1   | 1 | 1 | 1 | 1 | 1 | 1 | 1 | 1 | 1 | 1 | 1 | 1 | 1 | 1 | 0   |
| NOR-4    | 0   | 0 | 0 | 0 | 0 | 0 | 0 | 0 | 0 | 0 | 0 | 0 | 0 | 0 | 0 | 1   |
| XOR-4    | 0   | 1 | 1 | 0 | 1 | 0 | 0 | 1 | 1 | 1 | 0 | 0 | 1 | 1 | 1 | 0   |
| XNOR-4   | 1   | 0 | 0 | 1 | 0 | 1 | 1 | 0 | 0 | 0 | 1 | 1 | 0 | 0 | 0 | 1   |

SLG46855-A

Auto AEC-Q100 Qualified GreenPAK Programmable Mixed-Signal Matrix

8.3 CNT/DLY/FSM TIMING DIAGRAMS

8.3.1 Delay Mode CNT/DLY0 to CNT/DLY7

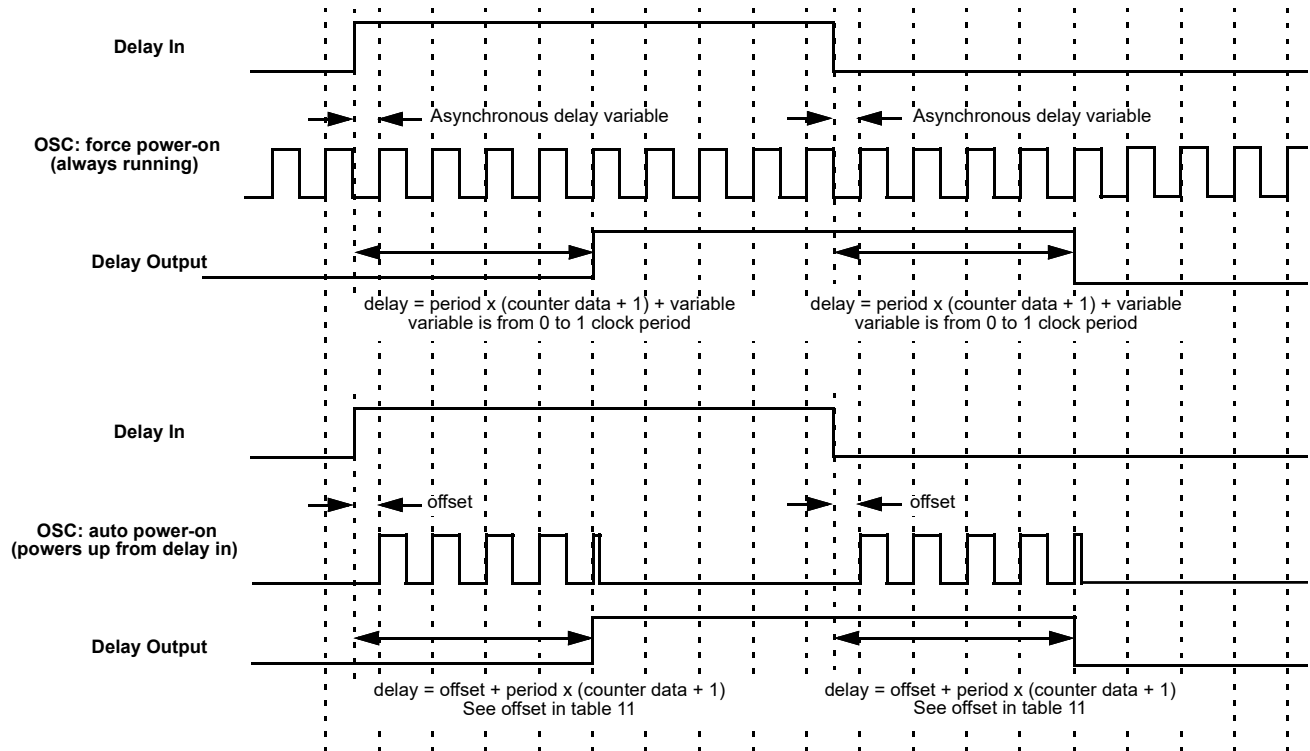

Figure 48: Delay Mode Timing Diagram, Edge Select: Both, Counter Data: 3

SLG46855-A

Auto AEC-Q100 Qualified GreenPAK Programmable Mixed-Signal Matrix

The macrocell shifts the respective edge to a set time and restarts by appropriate edge. It works as a filter, if the input signal is shorter than the delay time.

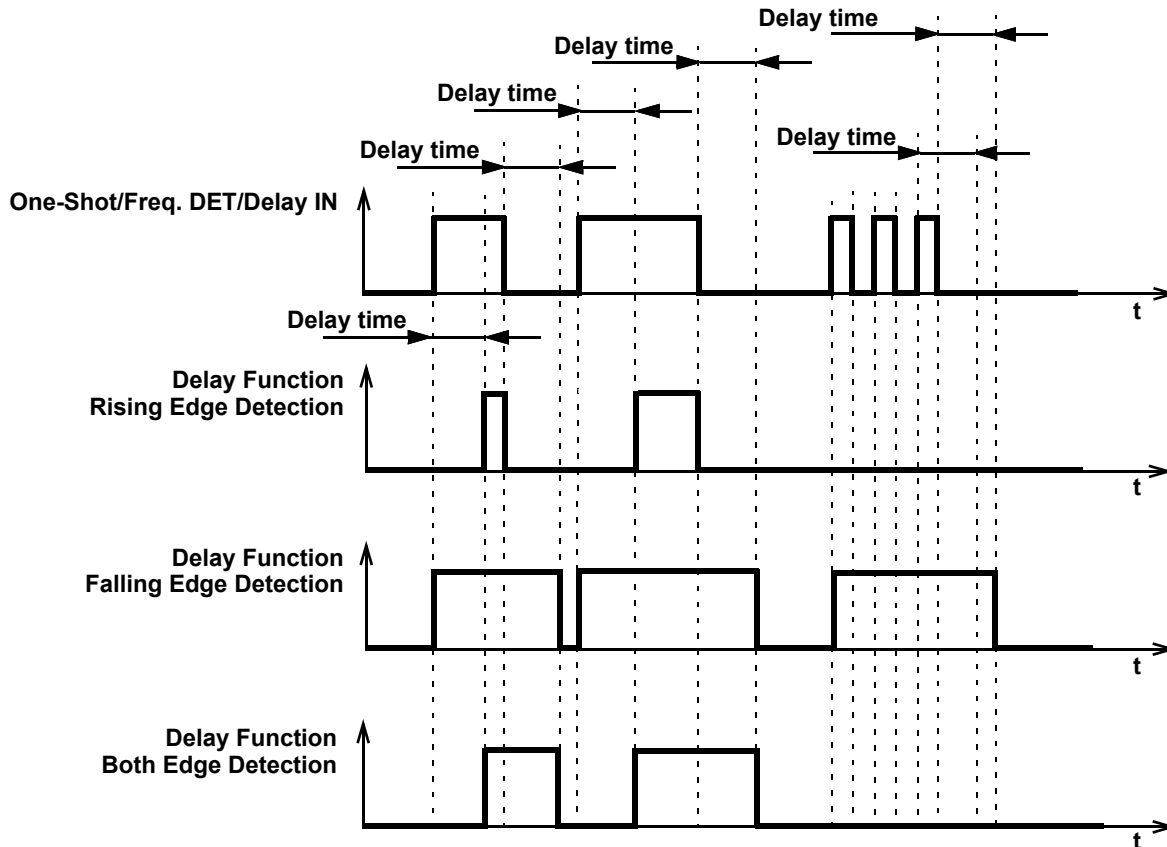

Figure 49: Delay Mode Timing Diagram for Different Edge Select Mode

8.3.2 Count Mode (Count Data: 3), Counter Reset (Rising Edge Detect) CNT/DLY0 to CNT/DLY7

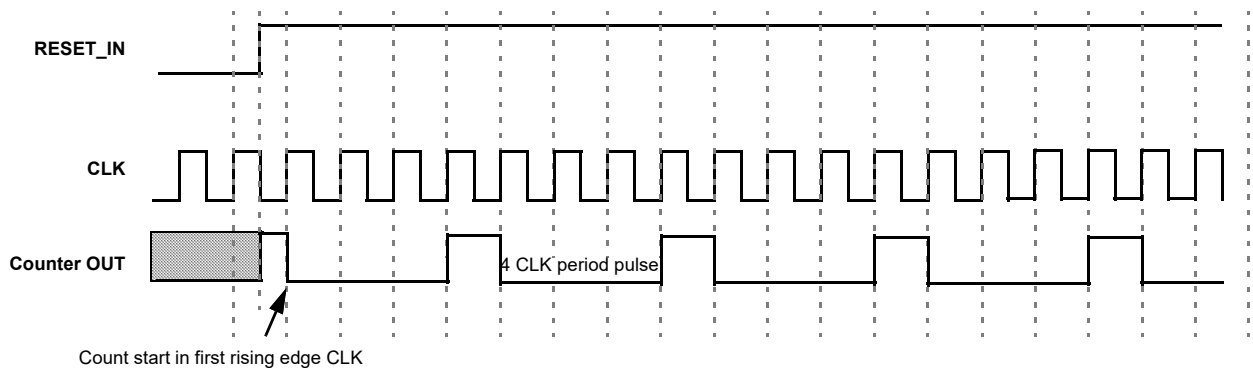

Figure 50: Counter Mode Timing Diagram without Two DFFs Synced Up

SLG46855-A

Auto AEC-Q100 Qualified GreenPAK Programmable Mixed-Signal Matrix

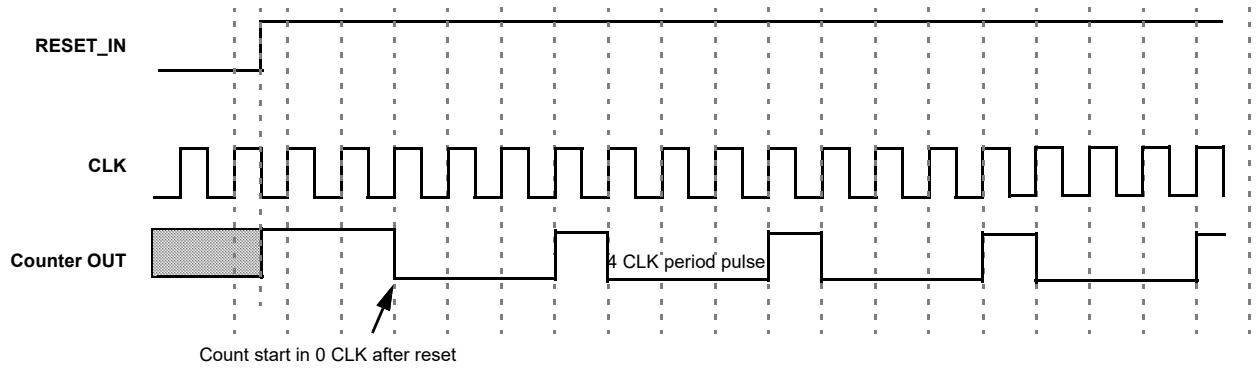

Figure 51: Counter Mode Timing Diagram with Two DFFs Synced Up

SLG46855-A

Auto AEC-Q100 Qualified GreenPAK Programmable Mixed-Signal Matrix

8.3.3 One-Shot Mode CNT/DLY0 to CNT/DLY7

This macrocell will generate a pulse whenever a selected edge is detected on its input. Register bits set the edge selection. The pulse width determines by counter data and clock selection properties. The output pulse polarity (non-inverted or inverted) is selected by register bit. Any incoming edges will be ignored during the pulse width generation. The following diagram shows one-shot function for non-inverted output.

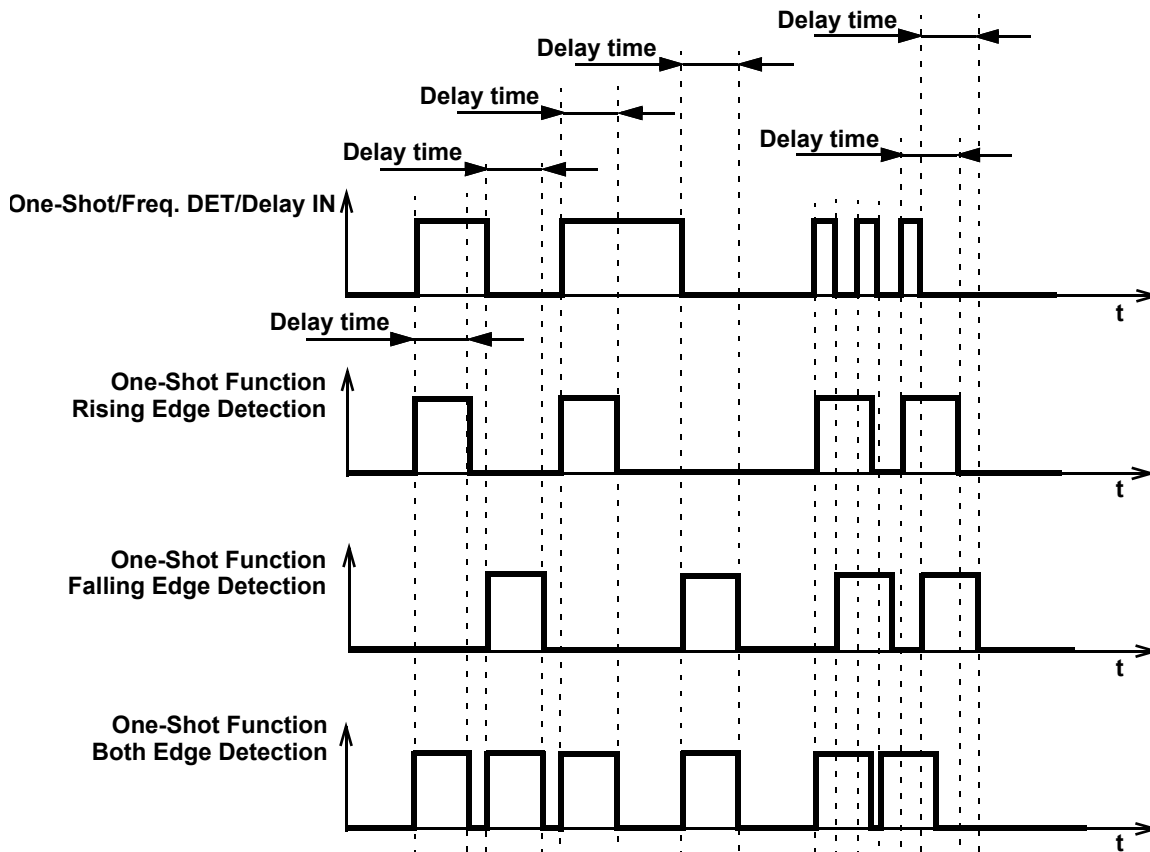

Figure 52: One-Shot Function Timing Diagram

This macrocell generates a high level pulse with a set width (defined by counter data) when detecting the respective edge. It does not restart while pulse is high.

8.3.4 Frequency Detection Mode CNT/DLY0 to CNT/DLY7

Rising Edge: The output goes high if the time between two successive edges is less than the delay. The output goes low if the second rising edge has not come after the last rising edge in specified time.

Falling Edge: The output goes high if the time between two falling edges is less than the set time. The output goes low if the second falling edge has not come after the last falling edge in specified time.

Both Edge: The output goes high if the time between the rising and falling edges is less than the set time, which is equivalent to the length of the pulse. The output goes low if after the last rising/falling edge and specified time, the second edge has not come.

SLG46855-A

Auto AEC-Q100 Qualified GreenPAK Programmable Mixed-Signal Matrix

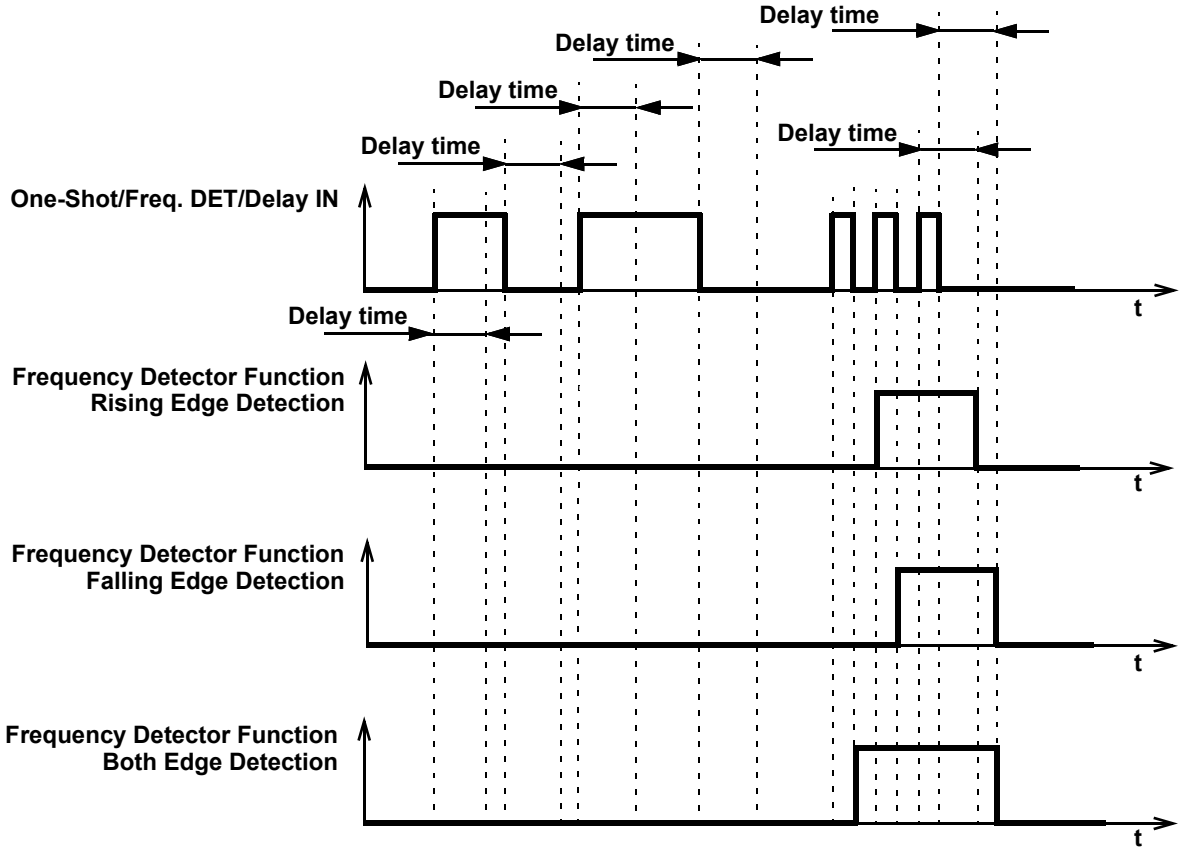

Figure 53: Frequency Detection Mode Timing Diagram

SLG46855-A

Auto AEC-Q100 Qualified GreenPAK Programmable Mixed-Signal Matrix

8.3.5 Edge Detection Mode CNT/DLY1 to CNT/DLY7

The macrocell generates high level short pulse when detecting the respective edge. See Table 12.

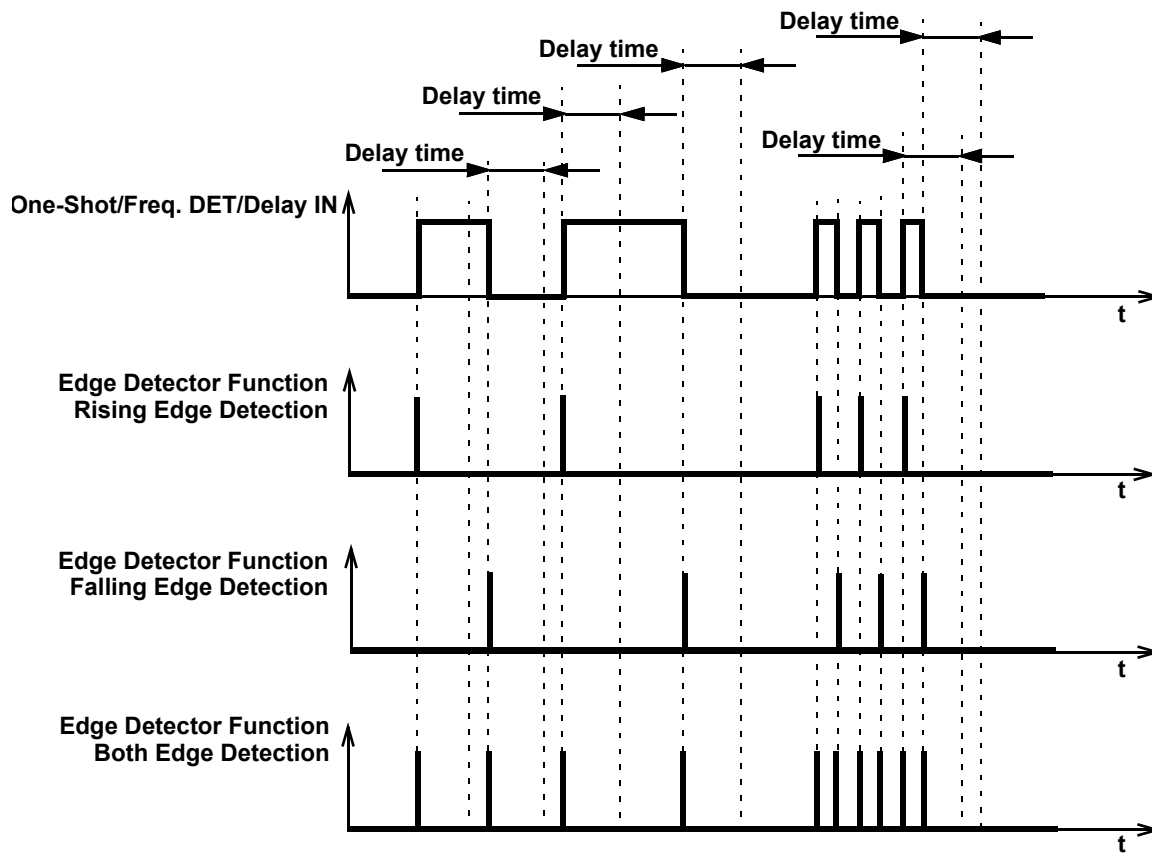

Figure 54: Edge Detection Mode Timing Diagram



SLG46855-A

Auto AEC-Q100 Qualified GreenPAK Programmable Mixed-Signal Matrix

8.3.6 Delayed Edge Detection Mode CNT/DLY0 to CNT/DLY7

In Delayed Edge Detection Mode, High level short pulses are generated on the macrocell output after the configured delay time, if the corresponding edge was detected on the input.

If the input signal is changed during the set delay time, the pulse will not be generated. See Figure 55.

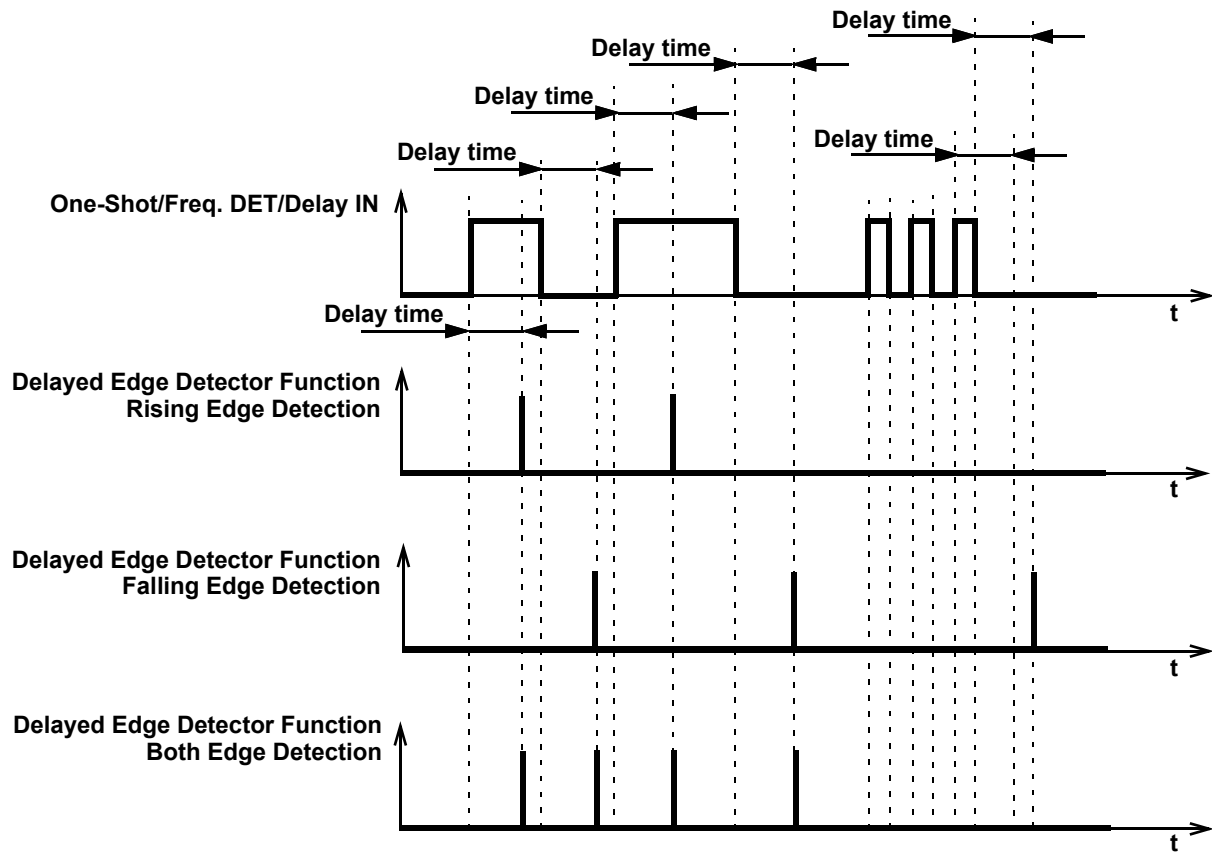

Figure 55: Delayed Edge Detection Mode Timing Diagram

SLG46855-A

Auto AEC-Q100 Qualified GreenPAK Programmable Mixed-Signal Matrix

8.3.7 CNT/FSM Mode CNT/DLY0

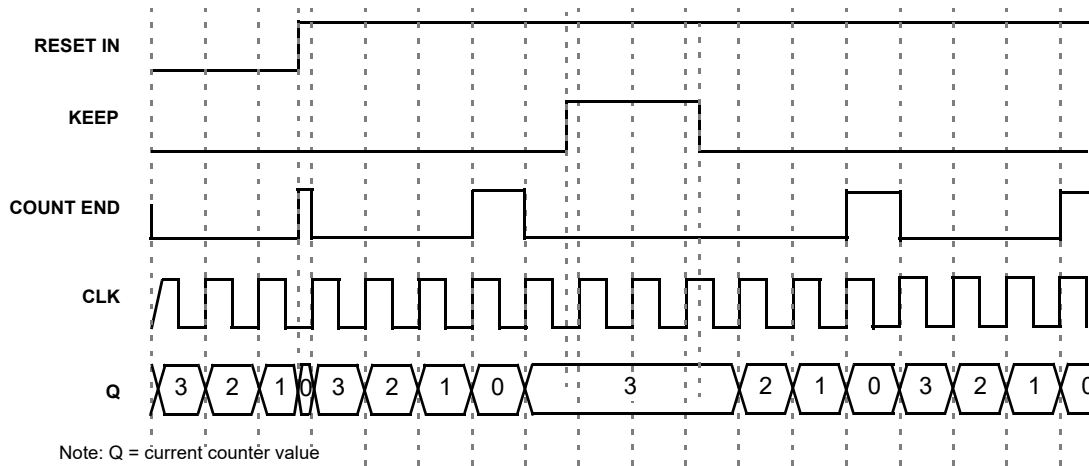

Figure 56: CNT/FSM Timing Diagram (Reset Rising Edge Mode, Oscillator is Forced On, UP = 0) for Counter Data = 3

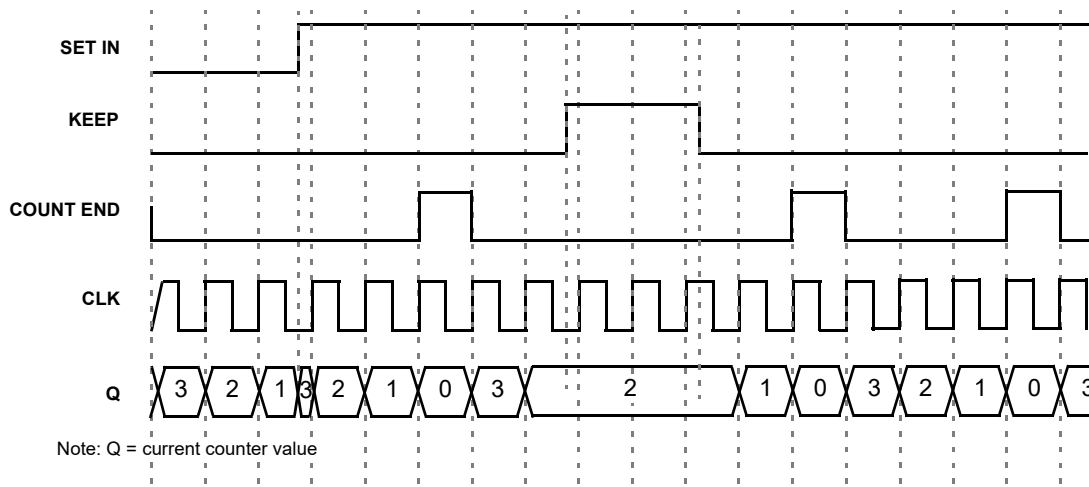

Figure 57: CNT/FSM Timing Diagram (Set Rising Edge Mode, Oscillator is Forced On, UP = 0) for Counter Data = 3

SLG46855-A

Auto AEC-Q100 Qualified GreenPAK Programmable Mixed-Signal Matrix

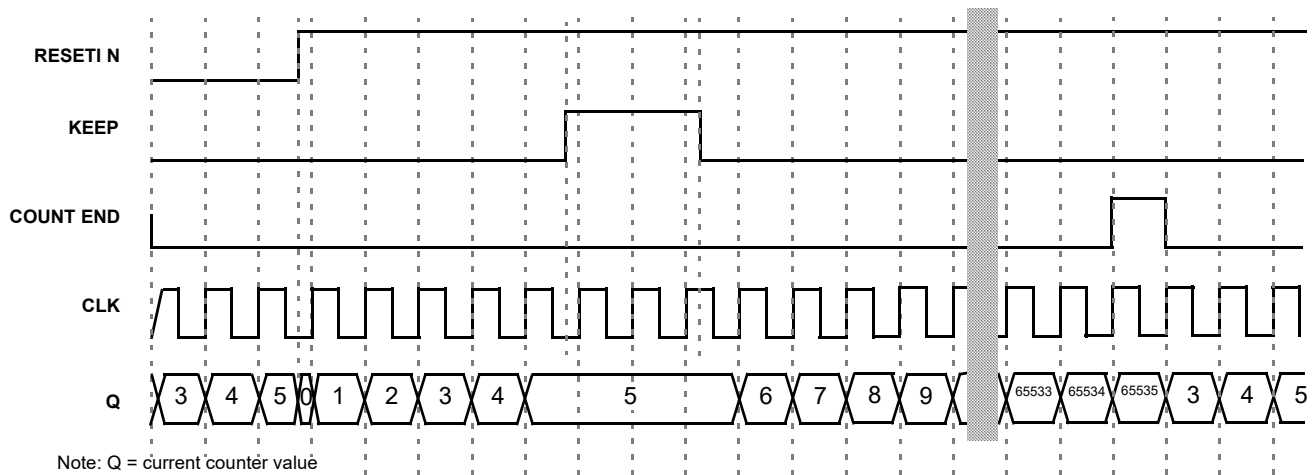

Figure 58: CNT/FSM Timing Diagram (Reset Rising Edge Mode, Oscillator is Forced On, UP = 1) for Counter Data = 3

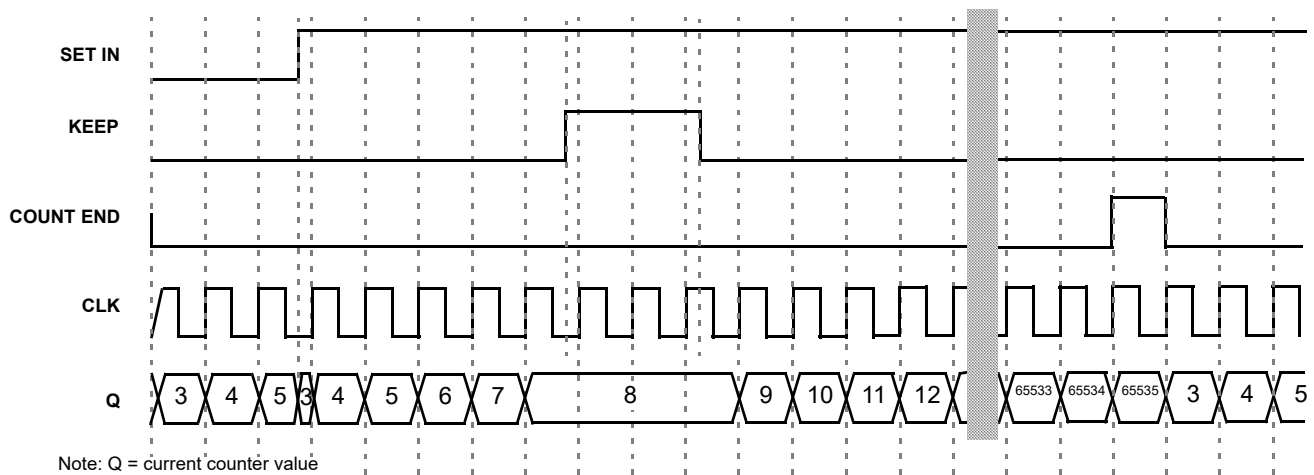

Figure 59: CNT/FSM Timing Diagram (Set Rising Edge Mode, Oscillator is Forced On, UP = 1) for Counter Data = 3

SLG46855-A

Auto AEC-Q100 Qualified GreenPAK Programmable Mixed-Signal Matrix

8.3.8 Difference in Counter Value for Counter, Delay, One-Shot, and Frequency Detect Modes

There is a difference in counter value for Counter and Delay/One-Shot/Frequency Detect modes. The counter value is shifted for two rising edges of the clock signal in Delay/One-Shot/Frequency Detect modes compared to Counter mode. See Figure 60:

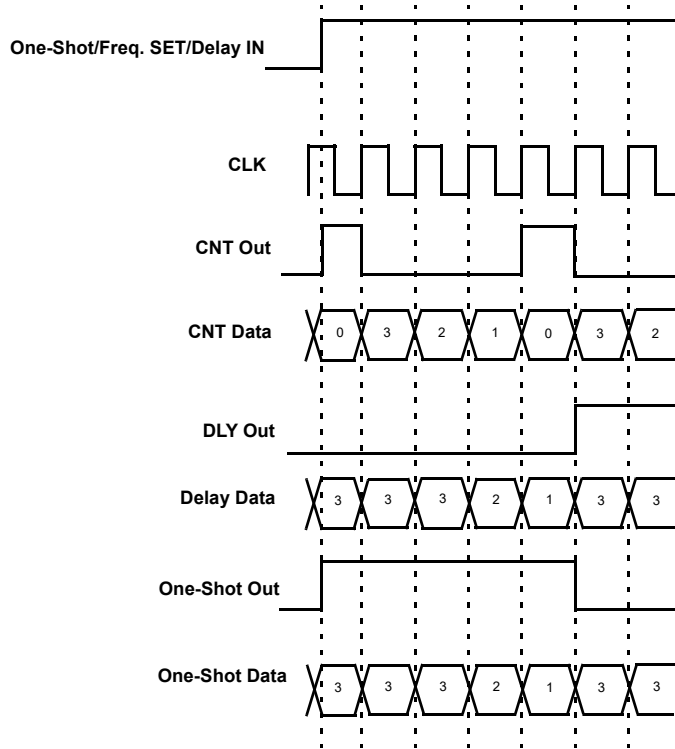

Figure 60: Counter Value, Counter Data = 3

8.4 WAKE AND SLEEP CONTROLLER

The SLG46855-A has a Wake and Sleep function for all ACMPs. The macrocell CNT/DLY0 can be reconfigured for this purpose registers [1032:1031] = 11 and register [1046] = 1. The WS serves for power saving, it allows to switch on and off selected ACMPs on selected bit of 16-bit counter.

**Note 1:** BG/Analog\_Good time is long and should be considered in wake and sleep timing in case it dynamically powers on/off.

SLG46855-A

Auto AEC-Q100 Qualified GreenPAK Programmable Mixed-Signal Matrix

**Note 2:** Wake time should be long enough to make sure ACMP and Vref have enough time to get a sample before going to sleep.

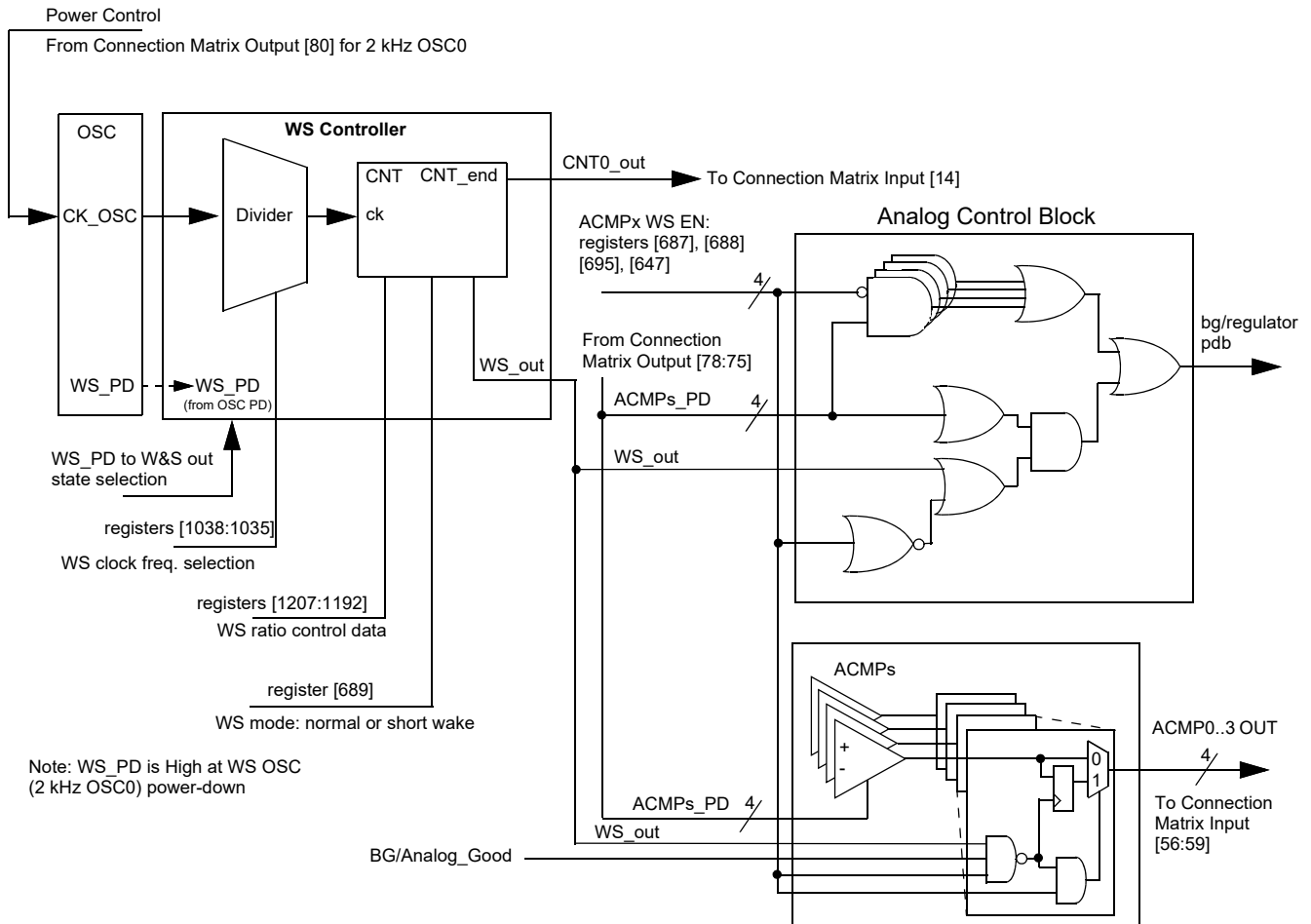

Figure 61: Wake/Sleep Controller

SLG46855-A

Auto AEC-Q100 Qualified GreenPAK Programmable Mixed-Signal Matrix

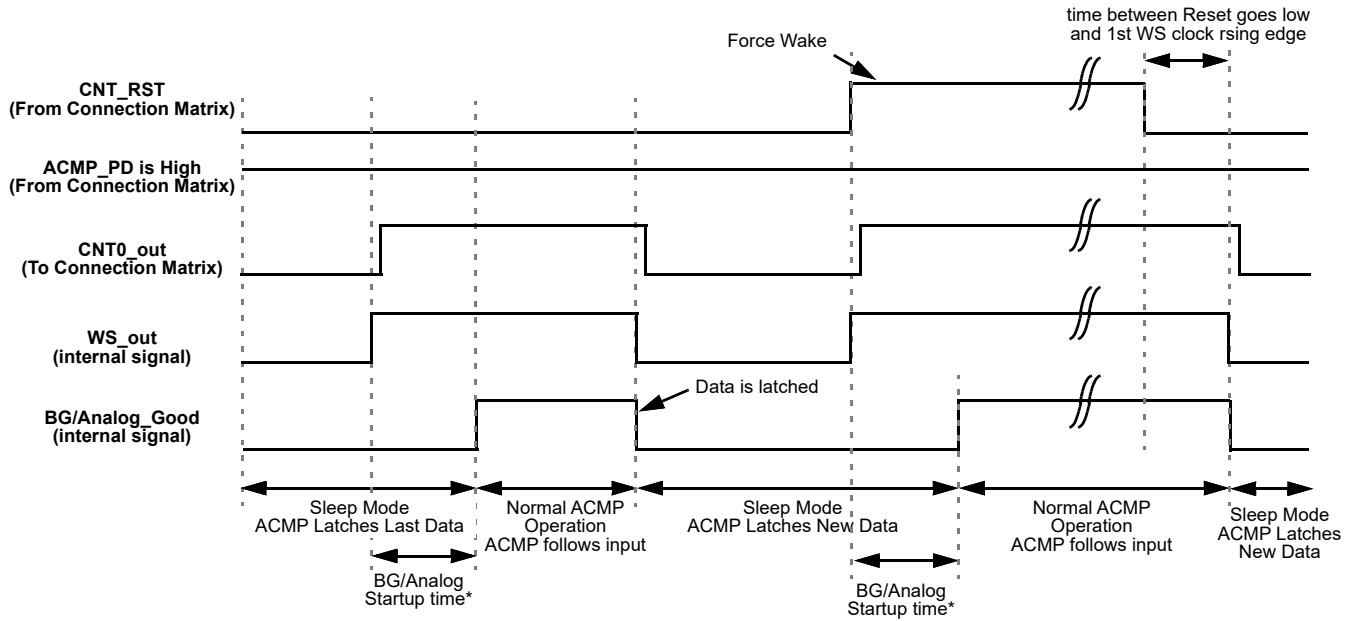

Figure 62: Wake/Sleep Timing Diagram, Normal Wake Mode, Counter Reset is Used

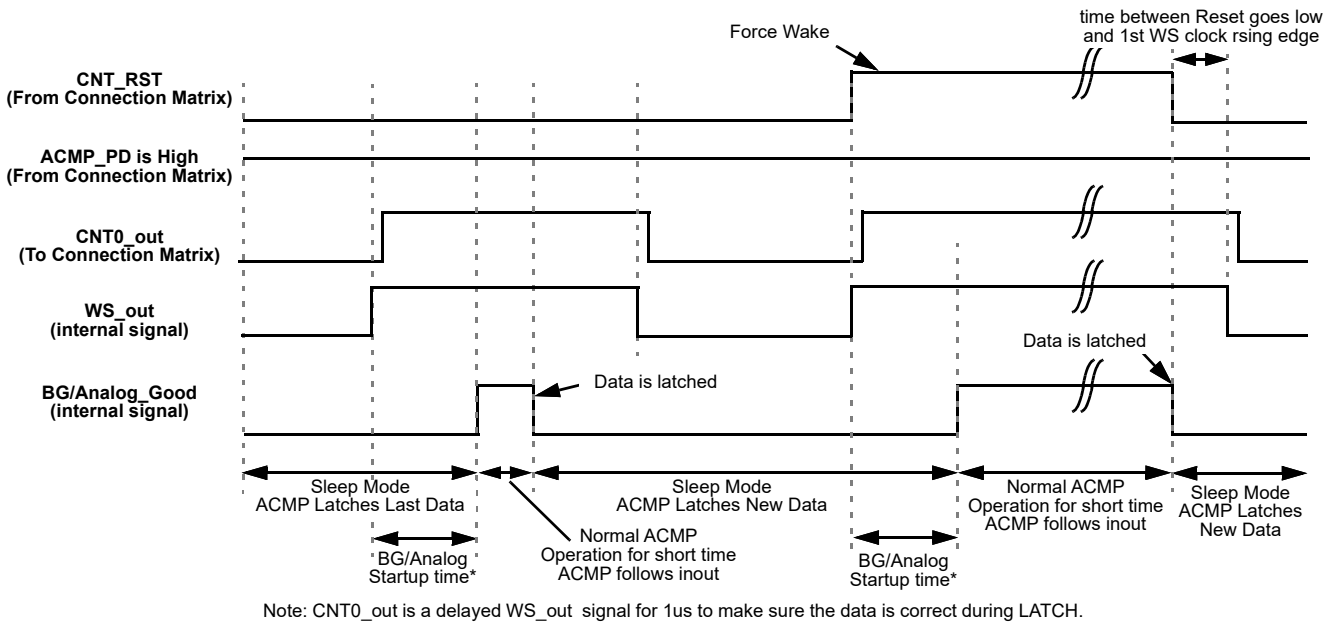

Figure 63: Wake/Sleep Timing Diagram, Short Wake Mode, Counter Reset is Used

SLG46855-A

Auto AEC-Q100 Qualified GreenPAK Programmable Mixed-Signal Matrix

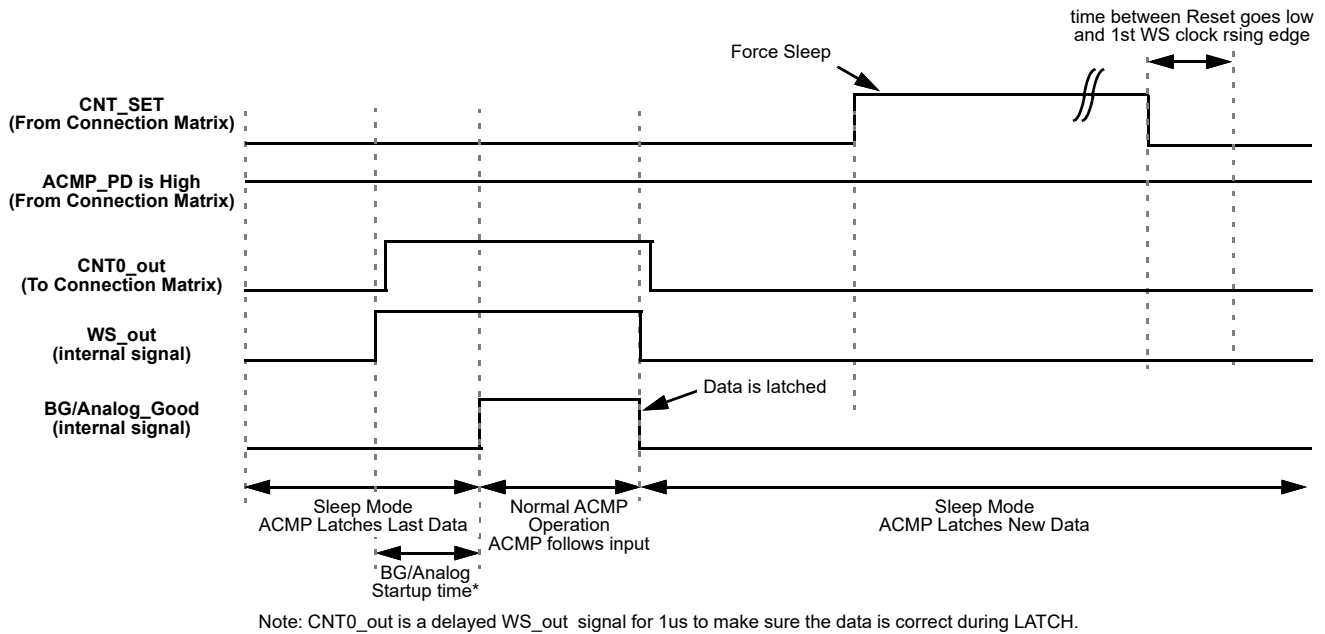

Figure 64: Wake/Sleep Timing Diagram, Normal Wake Mode, Counter Set is Used

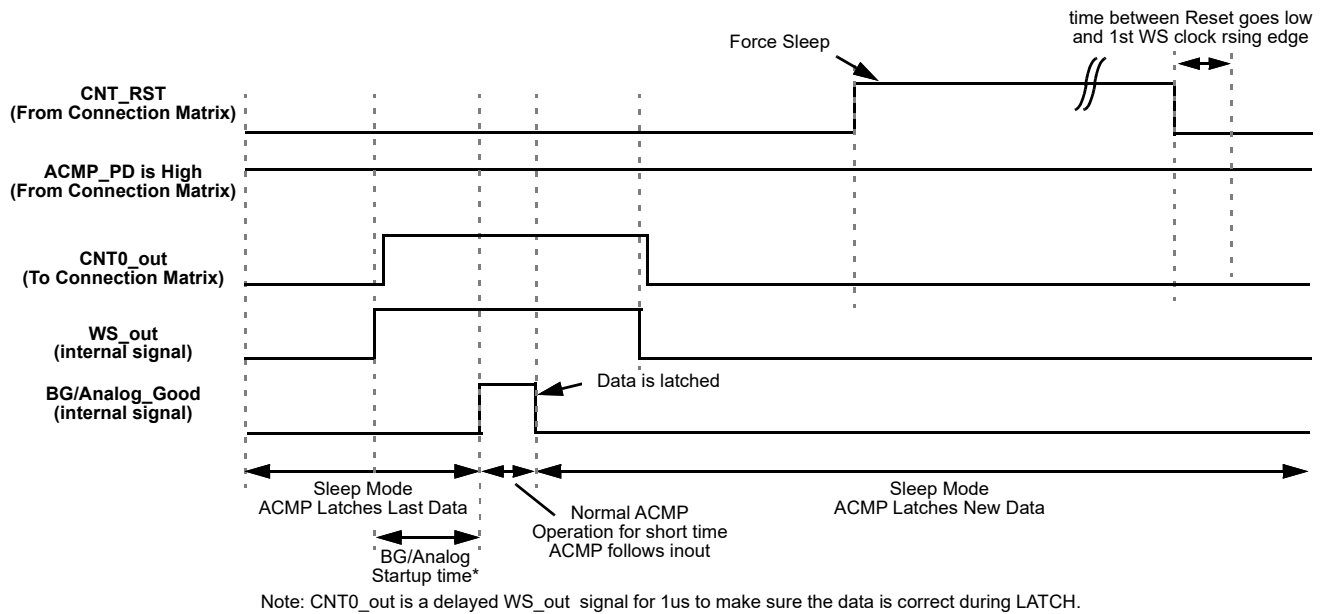

Figure 65: Wake/Sleep Timing Diagram, Short Wake Mode, Counter Set is Used

**Note:** If low power BG is powered on/off by WS, the wake time should be longer than 2.1 ms. The BG/analog start up time will take maximal 2 ms. Therefore, 8 periods of the Oscillator0 is recommended for the wake time, when BG is configured to Auto Power mode. If low power BG is always on, Oscillator0 period is longer than required wake time. The BG/analog start up time will

## Auto AEC-Q100 Qualified GreenPAK Programmable Mixed-Signal Matrix

take maximal 450 us for ACMP0/1 and a shorter time for ACMP2/3. The short wake mode can be used to reduce the current consumption.

To use any ACMP under WS controller, the following settings must be done:

- ACMP Power Up Input from matrix = 1 (for each ACMP separately);
- CNT/DLY0 must be set to Wake and Sleep Controller function (for all ACMP);
- Register WS → enable (for each ACMP separately);
- CNT/DLY0 set/reset input = 0 (for all ACMP).

The user can select a period of time while the ACMP is sleeping in a range of 1 - 65535 clock cycles. Before they are sent to sleep their outputs are latched, so the ACMPs remain their state (High or Low) while sleeping.

WS controller has the following settings:

- Wake and Sleep Output State (High/Low)
  - If OSC is powered off (Power-down option is selected; Power-down input = 1) and Wake and Sleep Output State = High, the ACMP is continuously on.
  - If OSC is powered off (Power-down option is selected; Power-down input = 1) and Wake and Sleep Output State = Low, the ACMP is continuously off.
  - Both cases WS function is turned off.
- Counter Data (Range: 1 - 65535)
  - User can select wake and sleep ratio of the ACMP; counter data = sleep time, one clock = wake time.
- Q mode - defines the state of WS counter data when Set/Reset signal appears
  - Reset - when active signal appears, the WS counter will reset to zero and High level signal on its output will turn on the ACMPs. When Reset signal goes out, the WS counter will go Low and turn off the ACMP until the counter counts up to the end.
  - Set - when active signal appears, the WS counter will stop and Low level signal on its output will turn off the ACMP. When Set signal goes out, the WS counter will go on counting and High level signal will turn on the ACMP while counter is counting up to the end.

**Note:** The OSC0 matrix power-down to control ACMP WS is not supported for short wait time option.

- Edge Select defines the edge for Q mode
  - High level Set/Reset - switches mode Set/Reset when level is High

**Note:** Q mode operates only in case of "High Level Set/Reset".

- Wake time selection - time required for wake signal to turn the ACMPxH on

Normal Wake Time - when WS signal is High, it takes BG/analog start up time to turn the ACMPs on. They will stay on until WS signal is Low again. Wake time is one clock period. It should be longer than BG turn on time and minimal required comparing time of the ACMP.

Short Wake Time - when WS signal is High, it takes BG/analog start up time to turn the ACMPs on. They will stay on for 1 μs and turn off regardless of WS signal. The WS signal width does not matter.

- Keep - pauses counting while Keep = 1
- Up - reverses counting
  - If Up = 1, CNT is counting up from user selected value to 65535.
  - If Up = 0, CNT is counting down from user selected value to 0.



## 9 Analog Comparators

There are two High Speed and two Low Power Rail-to-Rail General Purpose Analog Comparators (ACMP) macrocells in the SLG46855-A. In order for the ACMP cells to be used in a GreenPAK design, the power up signals (ACMP0H PWR UP, ACMP1H PWR UP, ACMP2L PWR UP, and ACMP3L PWR UP) need to be active. By connecting to signals coming from the Connection Matrix, it is possible to have each ACMP be ON continuously, OFF continuously, or switched on periodically based on a digital signal coming from the Connection Matrix. When ACMP is powered down, its output is low.

Two of the four General Purpose Analog Comparators are optimized for high speed operation (ACMP0H and ACMP1H), and two other are optimized for low power operation (ACMP2L and ACMP3L).

Each of the ACMP cells has a positive input signal that can be provided by a variety of external sources, and can also have a selectable gain stage (1x, 0.5x, 0.33x, 0.25x) before connection to the analog comparator. The gain divider is unbuffered and has input resistance of 2 M $\Omega$  (typ) for 0.5x, 0.33x, 0.25x, and 10 G $\Omega$  for 1x. Each of the ACMP cells has a negative input signal that is either created from an internal Vref or provided by any external source (GPIO2 and GPO0). Note that the external Vref signal is filtered with a 2nd order low pass filter with 8 kHz typical bandwidth, see [Figure 66](#) to [Figure 69](#).

Input bias current < 1 nA (typ).

PWR UP = 1 => ACMP is powered up.

PWR UP = 0 => ACMP is powered down.

During power-up, the ACMP output will remain LOW, and then becomes valid in 37  $\mu$ s (max) after power up signal goes high for ACMP0H and ACMP1H, and becomes valid 294  $\mu$ s (max) after power up signal goes high for ACMP2L and ACMP3L.

Each High Speed ACMP (ACMP0H and ACMP1H) has an optional Rail-to-Rail Input Buffer, which can be used along with the Gain divider to increase ACMP input resistance. However, Input buffer will increase an input offset voltage.

Each cell also has a hysteresis selection, to offer hysteresis of (0, 32, 64, 192) mV. The hysteresis option is available when using an internal Vref only.

The ACMP0H has an additional option of connecting an internal 100  $\mu$ A current source to its positive input, register [690]. It is also possible to connect the 100  $\mu$ A current source to each next ACMP via an internal analog MUX.

ACMP0H IN+ options are GPIO4, buffered GPIO4, V<sub>DD</sub>, 100  $\mu$ A Current Source

ACMP1H IN+ options are GPIO5, buffered GPIO5, ACMP0H IN+ MUX output

ACMP2L IN+ options are GPIO6, ACMP0H IN+ MUX output, ACMP1H IN+ MUX output

ACMP3L IN+ options are GPIO7, ACMP2L IN+ MUX output, Temp Sensor OUT

SLG46855-A

Auto AEC-Q100 Qualified GreenPAK Programmable Mixed-Signal Matrix

9.1 ACMP0H BLOCK DIAGRAM

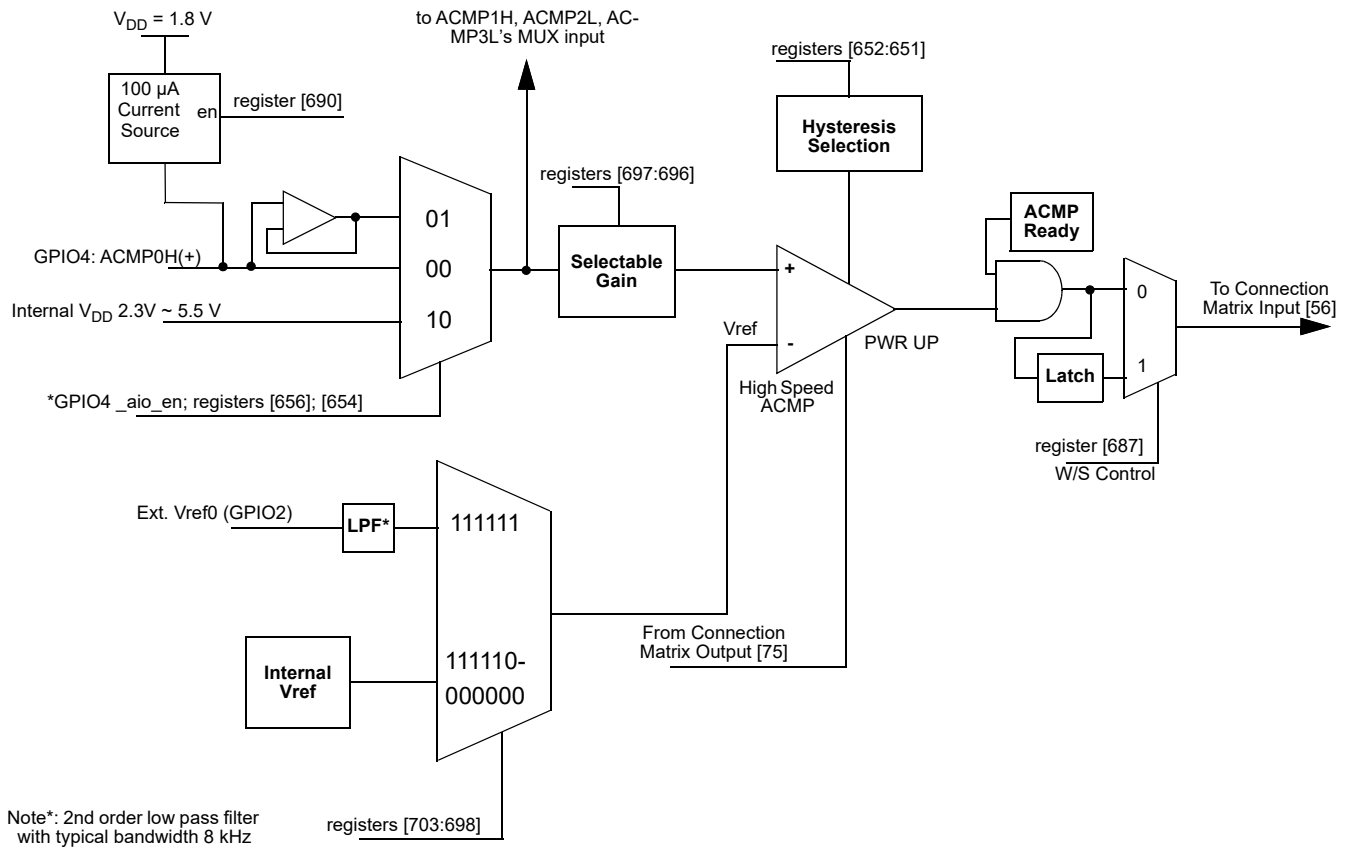

Figure 66: ACMP0H Block Diagram

SLG46855-A

Auto AEC-Q100 Qualified GreenPAK Programmable Mixed-Signal Matrix

9.2 ACMP1H BLOCK DIAGRAM

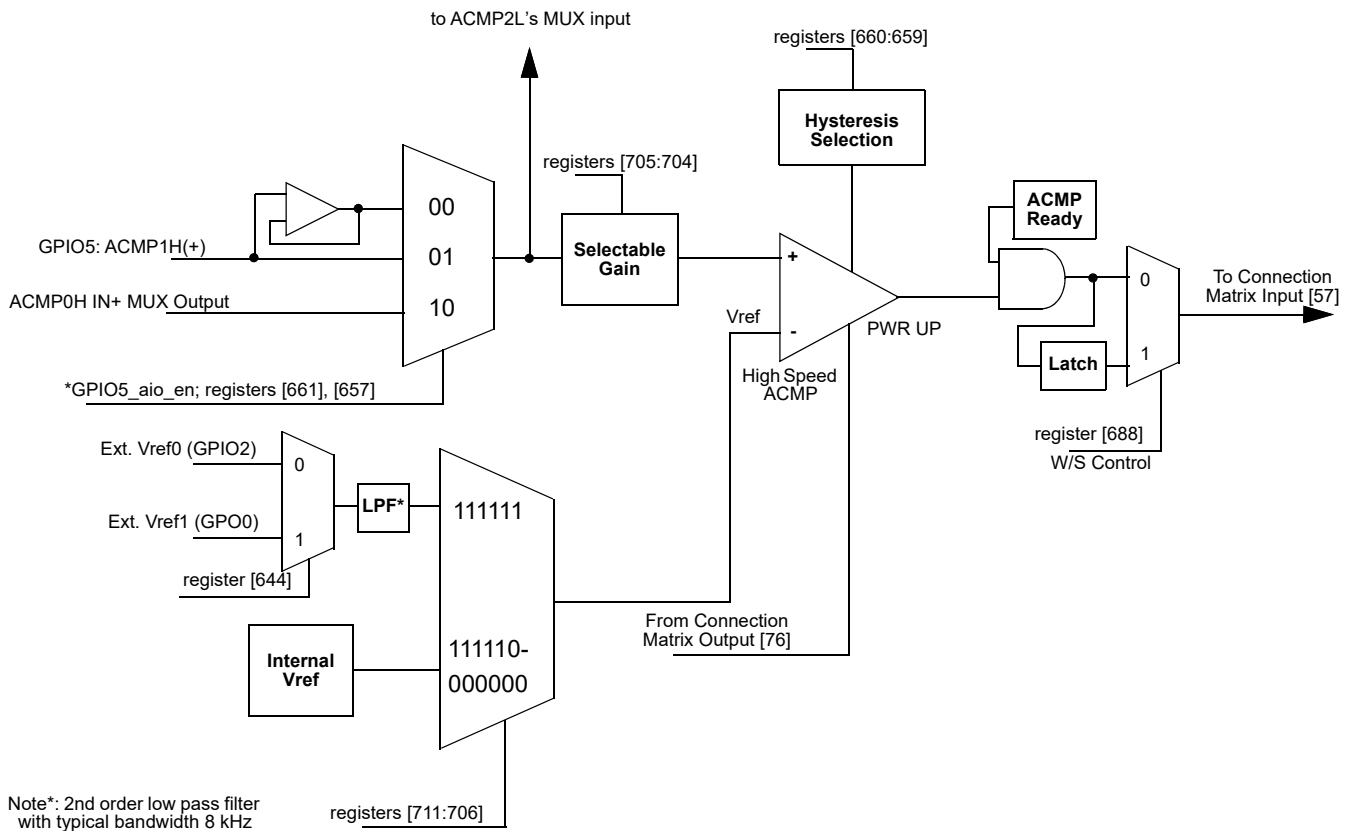

Figure 67: ACMP1H Block Diagram

SLG46855-A

Auto AEC-Q100 Qualified GreenPAK Programmable Mixed-Signal Matrix

9.3 ACMP2L BLOCK DIAGRAM

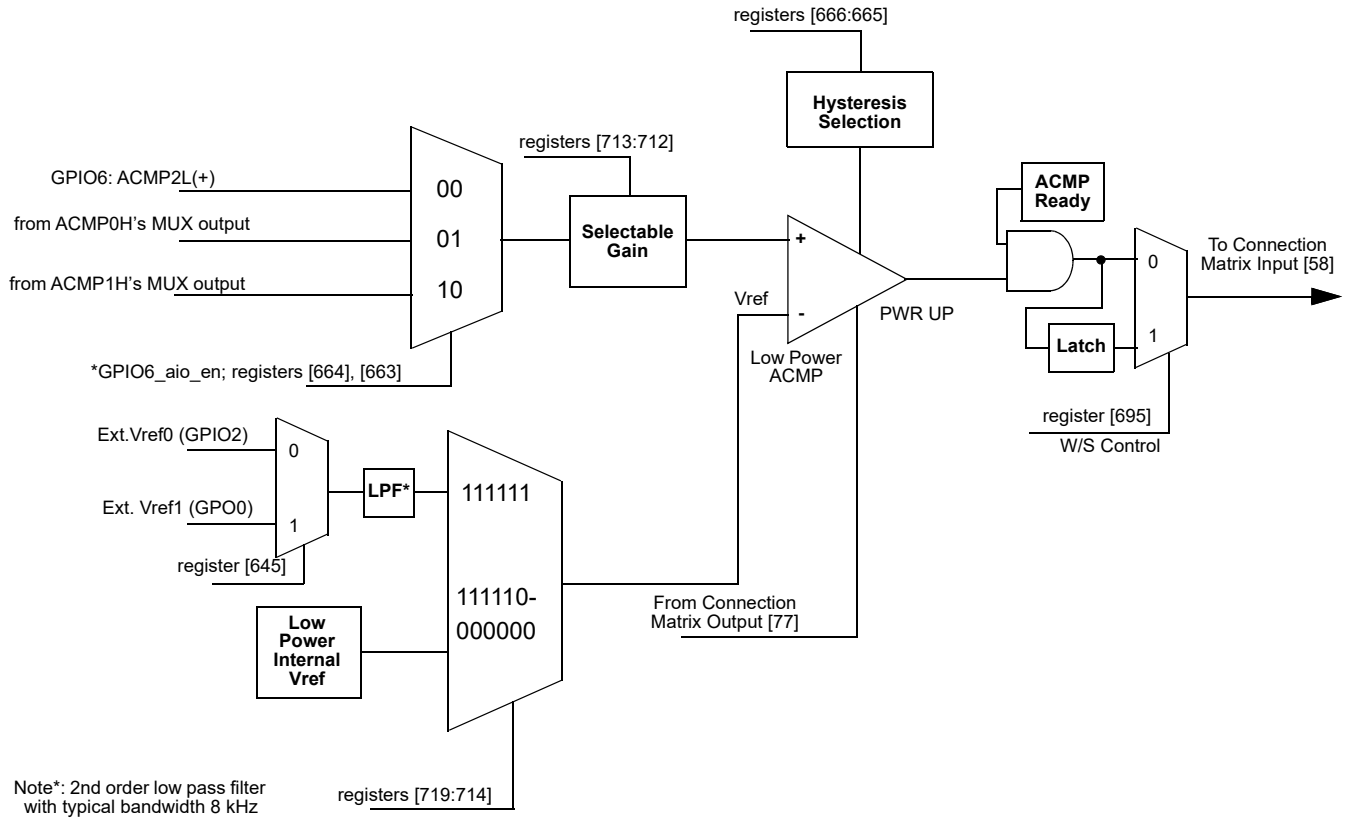

Figure 68: ACMP2L Block Diagram

SLG46855-A

Auto AEC-Q100 Qualified GreenPAK Programmable Mixed-Signal Matrix

9.4 ACMP3L BLOCK DIAGRAM

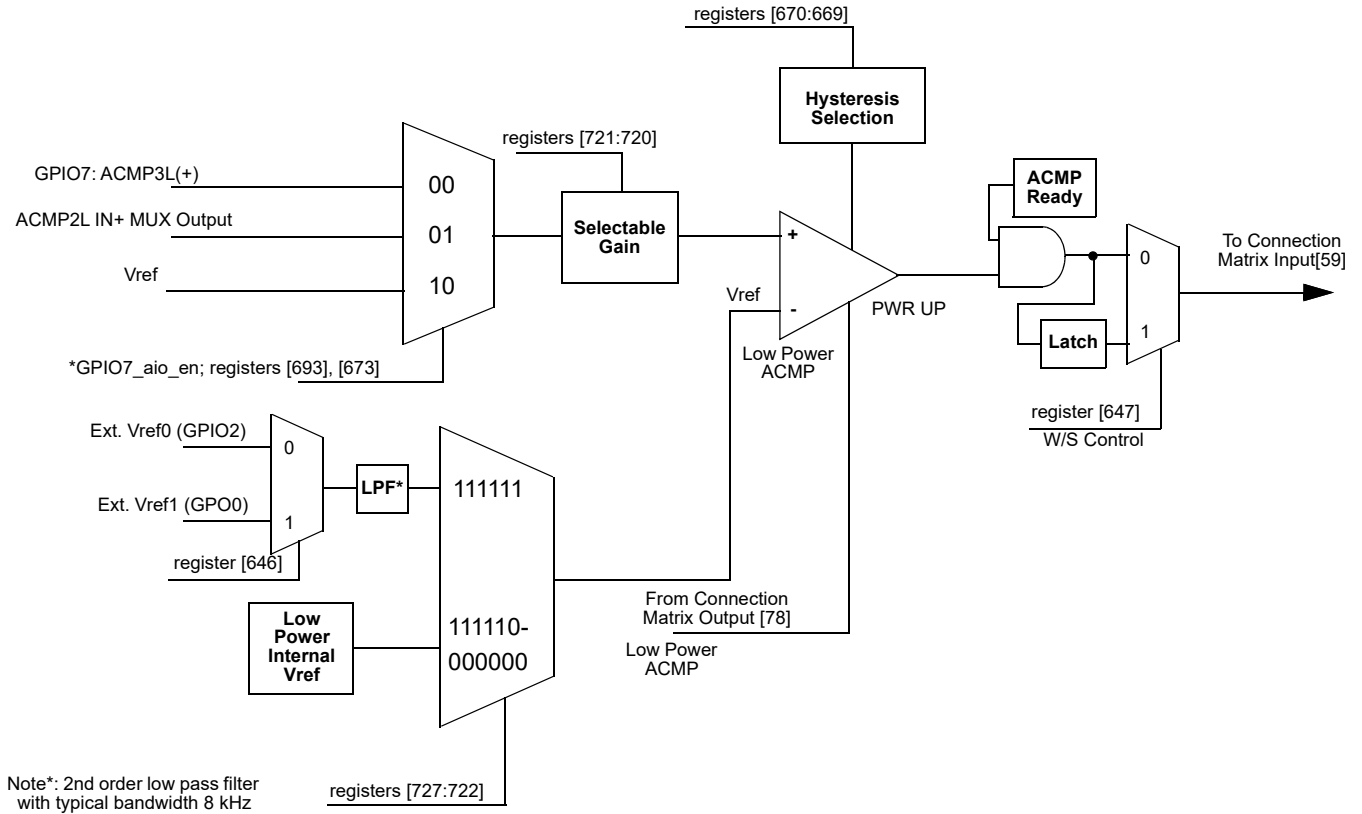

Figure 69: ACMP3L Block Diagram

SLG46855-A

Auto AEC-Q100 Qualified GreenPAK Programmable Mixed-Signal Matrix

9.5 ACMP TYPICAL PERFORMANCE

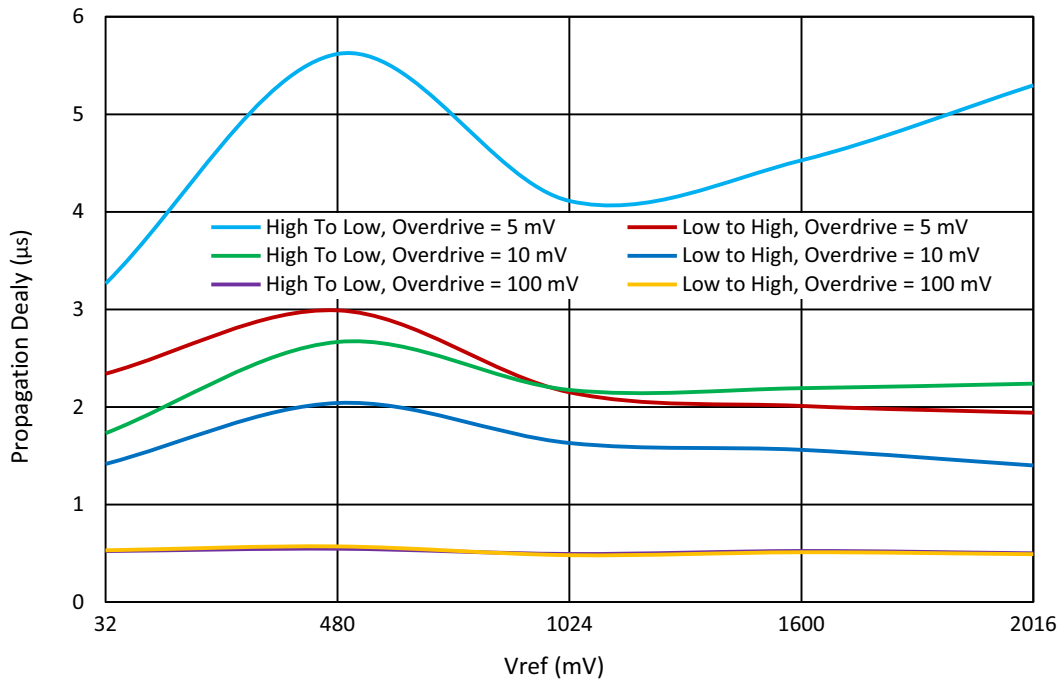

Figure 70: Typical Propagation Delay vs. Vref for ACMPxH at T = 25 °C, Gain = 1, Hysteresis = 0

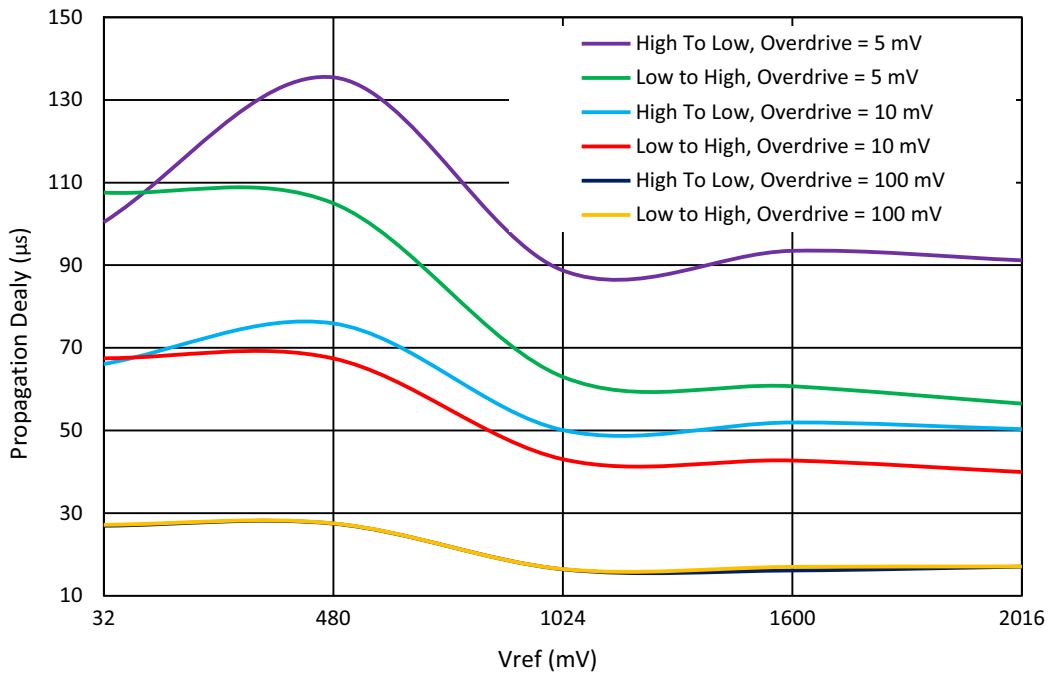

Figure 71: Typical Propagation Delay vs. Vref for ACMPxL at T = 25 °C, Gain = 1, Hysteresis = 0

SLG46855-A

Auto AEC-Q100 Qualified GreenPAK Programmable Mixed-Signal Matrix

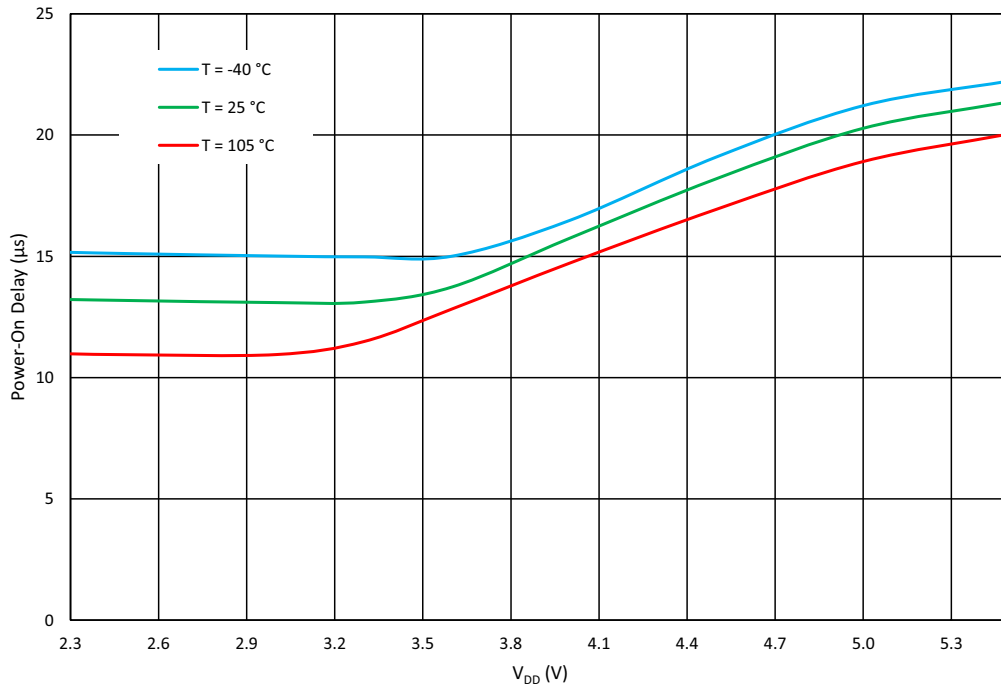

Figure 72: ACMPxH Power-On Delay vs. V<sub>DD</sub>

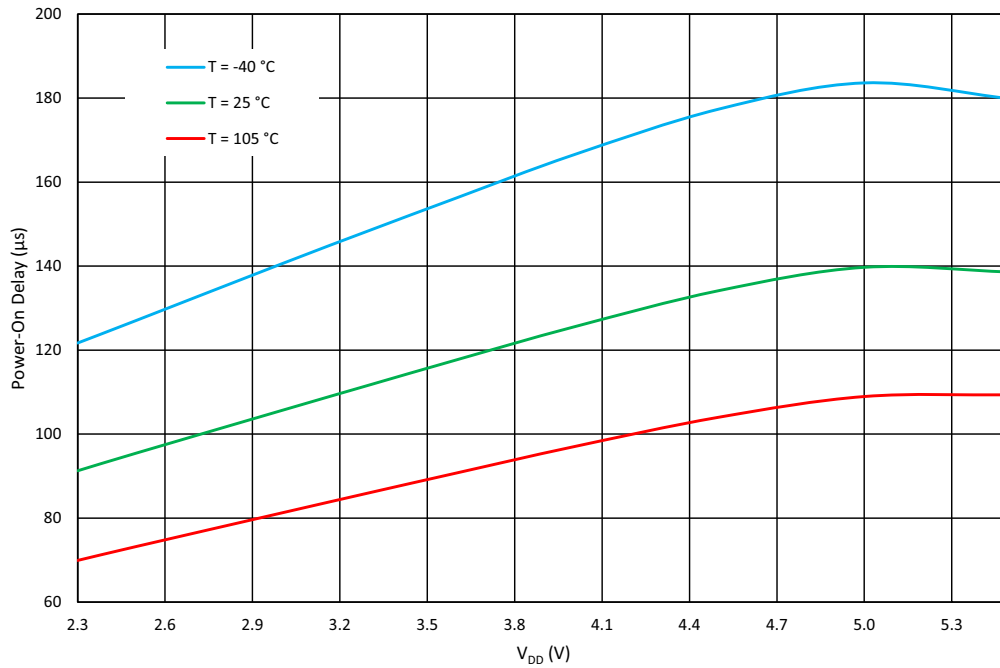

Figure 73: ACMPxL Power-On Delay vs. V<sub>DD</sub>

SLG46855-A

Auto AEC-Q100 Qualified GreenPAK Programmable Mixed-Signal Matrix

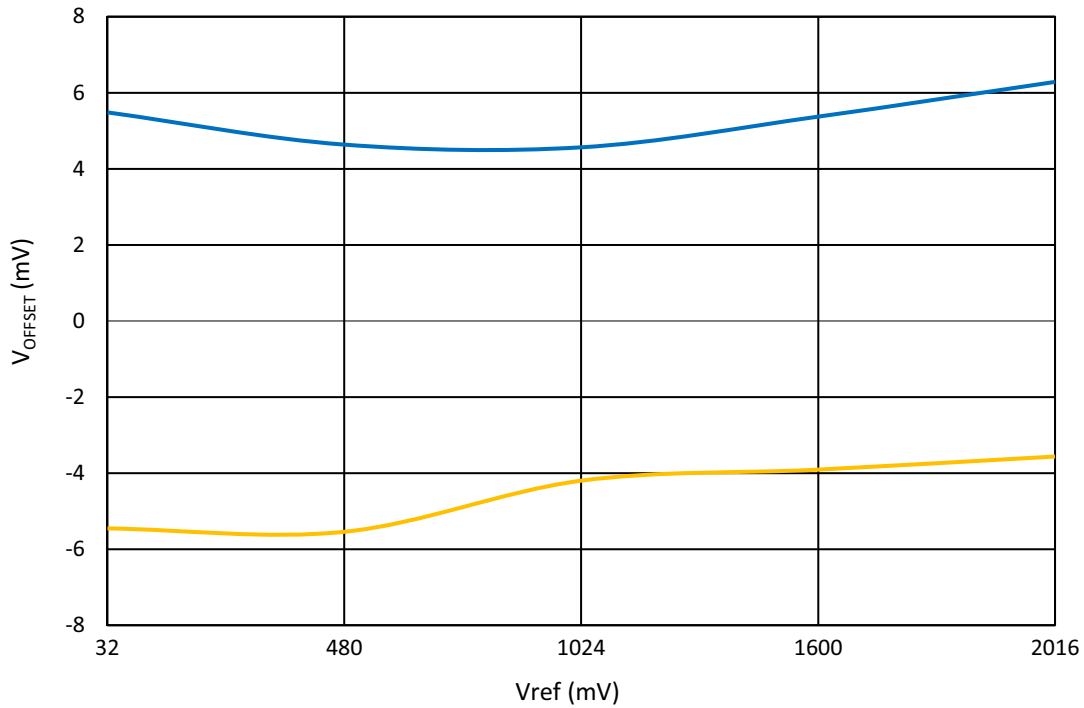

Figure 74: ACMPxH Input Offset Voltage vs. Vref at T = -40 °C to 105 °C

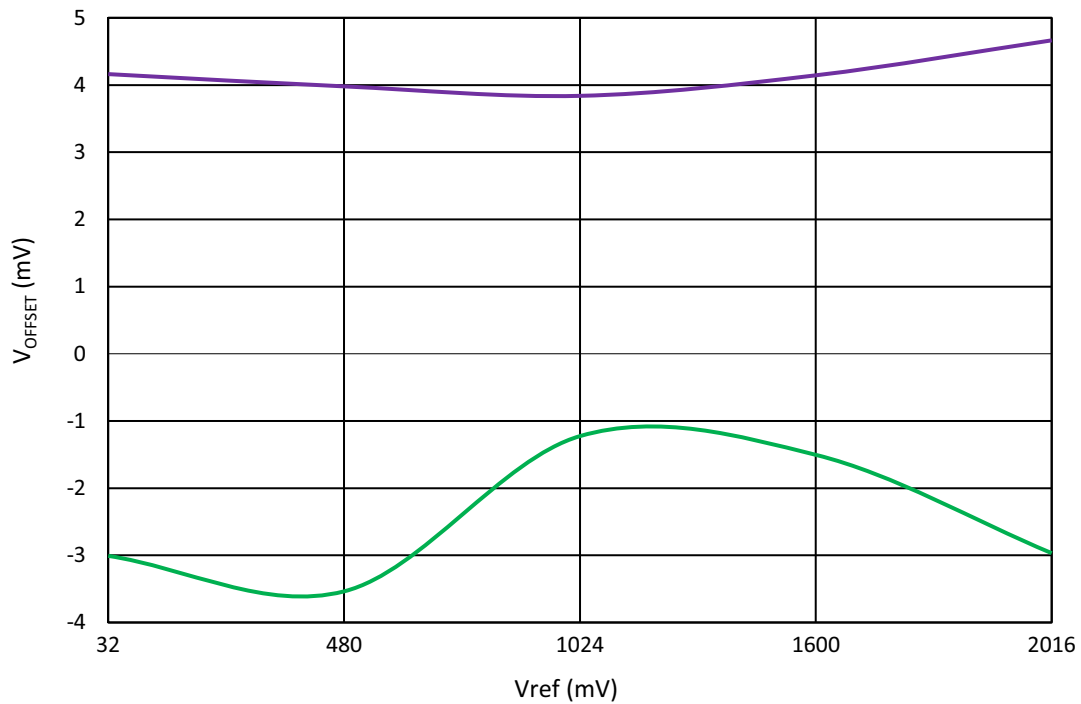

Figure 75: ACMPxL Input Offset Voltage vs. Vref at T = -40 °C to 105 °C



SLG46855-A

Auto AEC-Q100 Qualified GreenPAK Programmable Mixed-Signal Matrix

10 Programmable Delay/Edge Detector

The SLG46855-A has a programmable time delay logic cell that can generate a delay that is selectable from one of four timings (time2) configured in the GreenPAK Designer. The programmable time delay cell can generate one of four different delay patterns, rising edge detection, falling edge detection, both edge detection, and both edge delay. These four patterns can be further modified with the addition of delayed edge detection, which adds an extra unit of delay, as well as glitch rejection during the delay period. See Figure 76 for further information.

**Note:** The input signal must be longer than the delay, otherwise it will be filtered out.

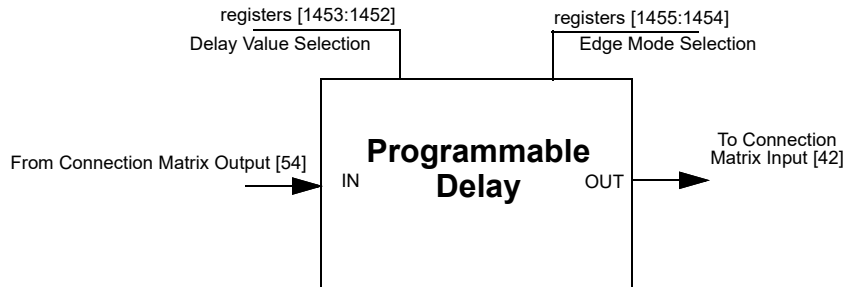

Figure 76: Programmable Delay

10.1 PROGRAMMABLE DELAY TIMING DIAGRAM - EDGE DETECTOR OUTPUT

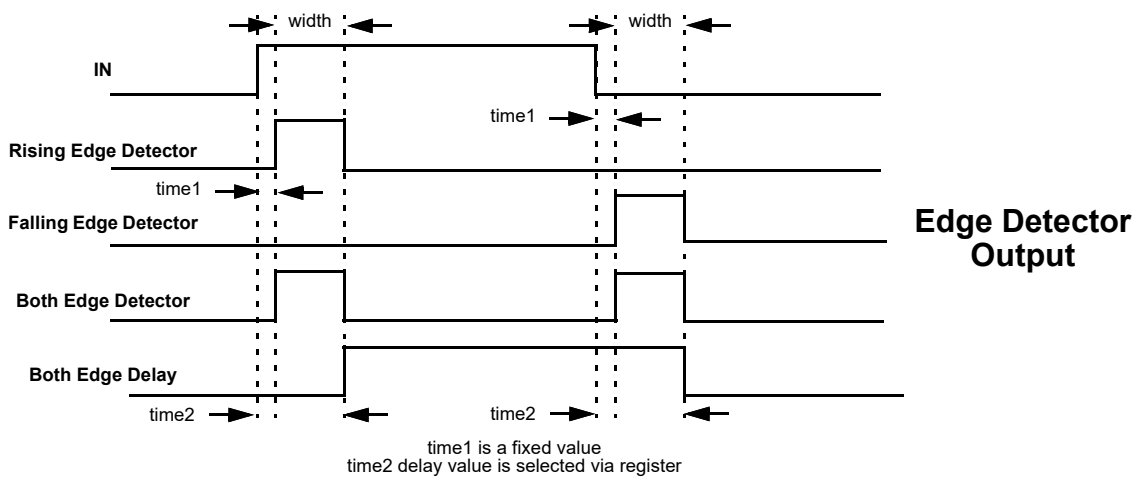

Figure 77: Edge Detector Output

Please refer to Table 12.

SLG46855-A

Auto AEC-Q100 Qualified GreenPAK Programmable Mixed-Signal Matrix

11 Additional Logic Function. Deglitch Filter

The SLG46855-A has one Deglitch Filter macrocell with inverter function that is connected directly to the Connection Matrix inputs and outputs. In addition, this macrocell can be configured as an Edge Detector, with the following settings:

- Rising Edge Detector
- Falling Edge Detector
- Both Edge Detector
- Both Edge Delay

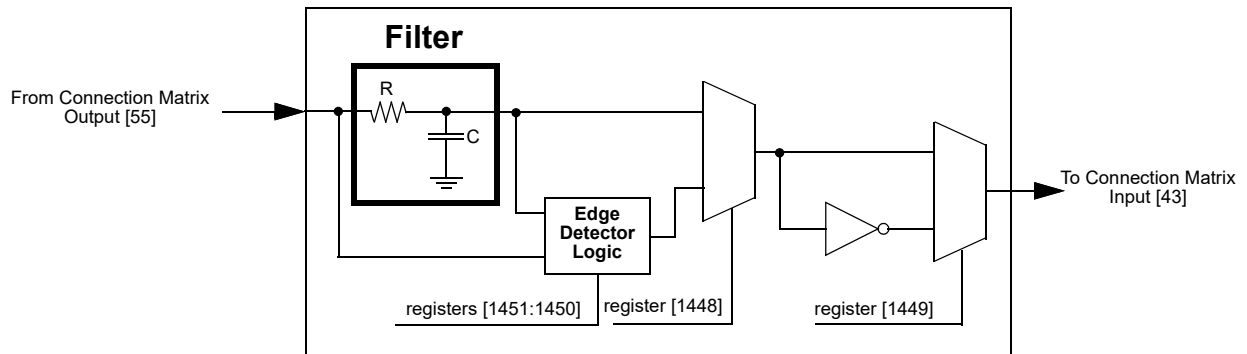

Figure 78: Deglitch Filter/Edge Detector

# SLG46855-A

## Auto AEC-Q100 Qualified GreenPAK Programmable Mixed-Signal Matrix

### 12 Voltage Reference

#### 12.1 VOLTAGE REFERENCE OVERVIEW

The SLG46855-A has a Voltage Reference (Vref) macrocell to provide references to the four analog comparators. This macrocell can supply a user selection of fixed voltage references, or temperature sensor output. The macrocell also has the option to output reference voltages on GPIO8 and GPIO9. See [Table 53](#) for the available selections for each analog comparator.

Also see [Figure 79](#), which shows the reference output structure.

#### 12.2 VREF SELECTION TABLE

**Table 54: Vref Selection Table**

| SEL[5:0] | Vref  | SEL[5:0] | Vref     |
|----------|-------|----------|----------|
| 0        | 0.032 | 32       | 1.056    |
| 1        | 0.064 | 33       | 1.088    |
| 2        | 0.096 | 34       | 1.12     |
| 3        | 0.128 | 35       | 1.152    |
| 4        | 0.16  | 36       | 1.184    |
| 5        | 0.192 | 37       | 1.216    |
| 6        | 0.224 | 38       | 1.248    |
| 7        | 0.256 | 39       | 1.28     |
| 8        | 0.288 | 40       | 1.312    |
| 9        | 0.32  | 41       | 1.344    |
| 10       | 0.352 | 42       | 1.376    |
| 11       | 0.384 | 43       | 1.408    |
| 12       | 0.416 | 44       | 1.44     |
| 13       | 0.448 | 45       | 1.472    |
| 14       | 0.48  | 46       | 1.504    |
| 15       | 0.512 | 47       | 1.536    |
| 16       | 0.544 | 48       | 1.568    |
| 17       | 0.576 | 49       | 1.6      |
| 18       | 0.608 | 50       | 1.632    |
| 19       | 0.64  | 51       | 1.664    |
| 20       | 0.672 | 52       | 1.696    |
| 21       | 0.704 | 53       | 1.728    |
| 22       | 0.736 | 54       | 1.76     |
| 23       | 0.768 | 55       | 1.792    |
| 24       | 0.8   | 56       | 1.824    |
| 25       | 0.832 | 57       | 1.856    |
| 26       | 0.864 | 58       | 1.888    |
| 27       | 0.896 | 59       | 1.92     |
| 28       | 0.928 | 60       | 1.952    |
| 29       | 0.96  | 61       | 1.984    |
| 30       | 0.992 | 62       | 2.016    |
| 31       | 1.024 | 63       | External |

SLG46855-A

Auto AEC-Q100 Qualified GreenPAK Programmable Mixed-Signal Matrix

12.3 VREF BLOCK DIAGRAM

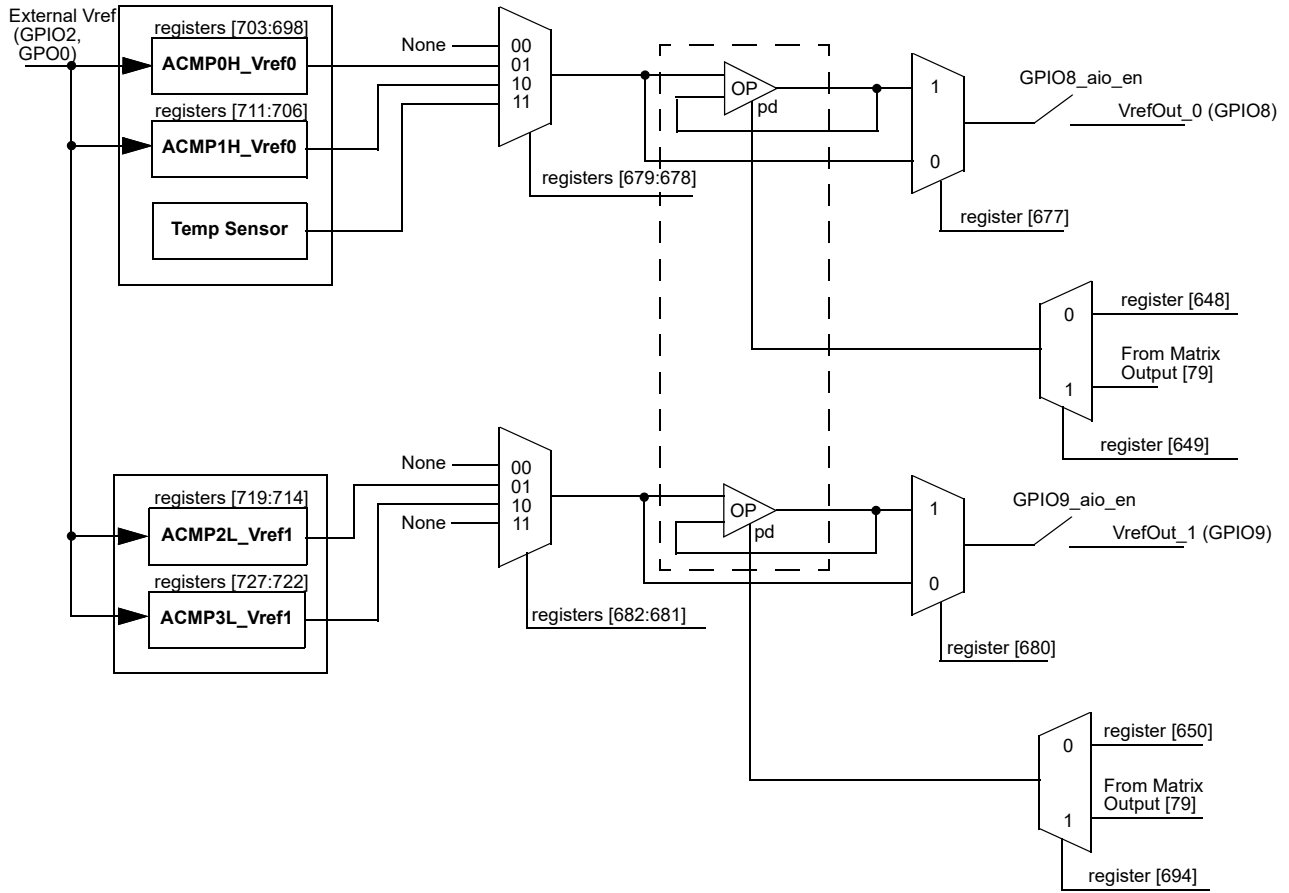

Figure 79: Voltage Reference Block Diagram

SLG46855-A

Auto AEC-Q100 Qualified GreenPAK Programmable Mixed-Signal Matrix

12.4 VREF LOAD REGULATION

**Note 1** It is not recommended to use Vref connected to external pin without buffer.

**Note 2** Vref buffer performance is not guaranteed at  $V_{DD} < 2.7$  V.

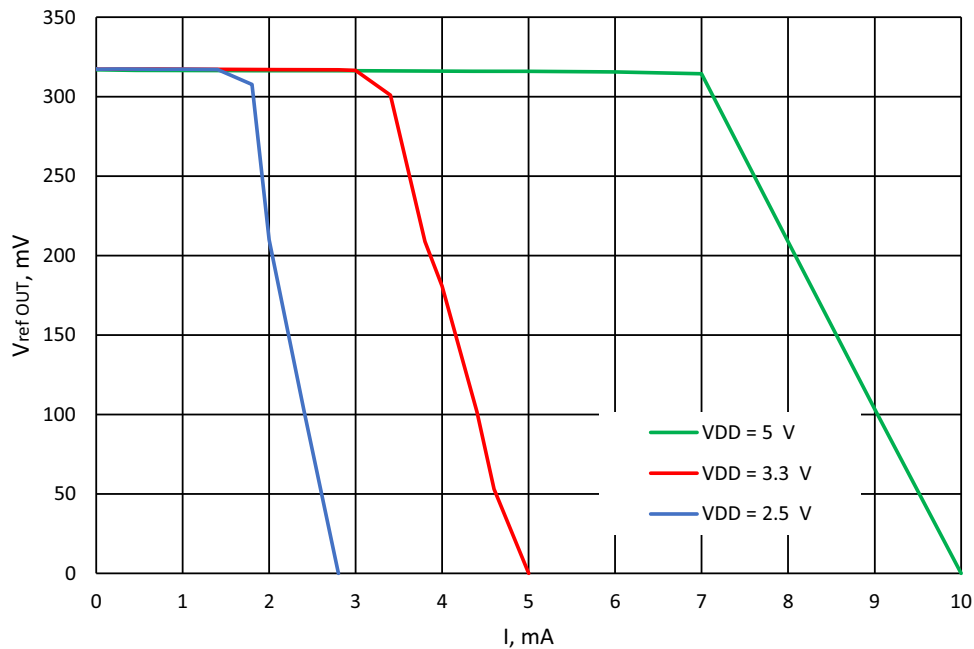

Figure 80: Typical Load Regulation, Vref = 320 mV, T = -40 °C to +105 °C, Buffer - Enabled

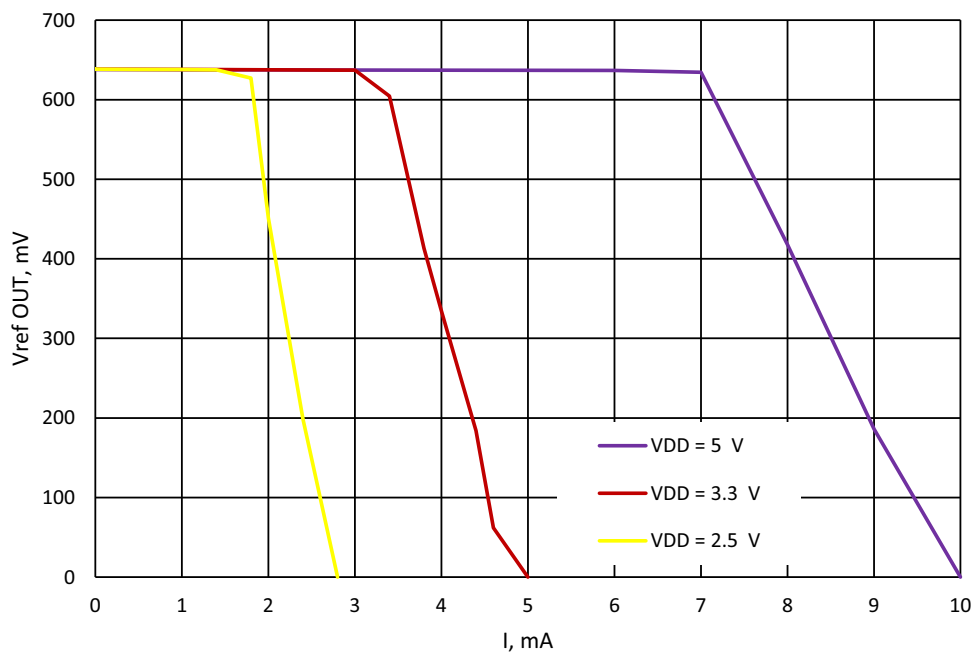

Figure 81: Typical Load Regulation, Vref = 640 mV, T = -40 °C to +105 °C, Buffer - Enabled

SLG46855-A

Auto AEC-Q100 Qualified GreenPAK Programmable Mixed-Signal Matrix

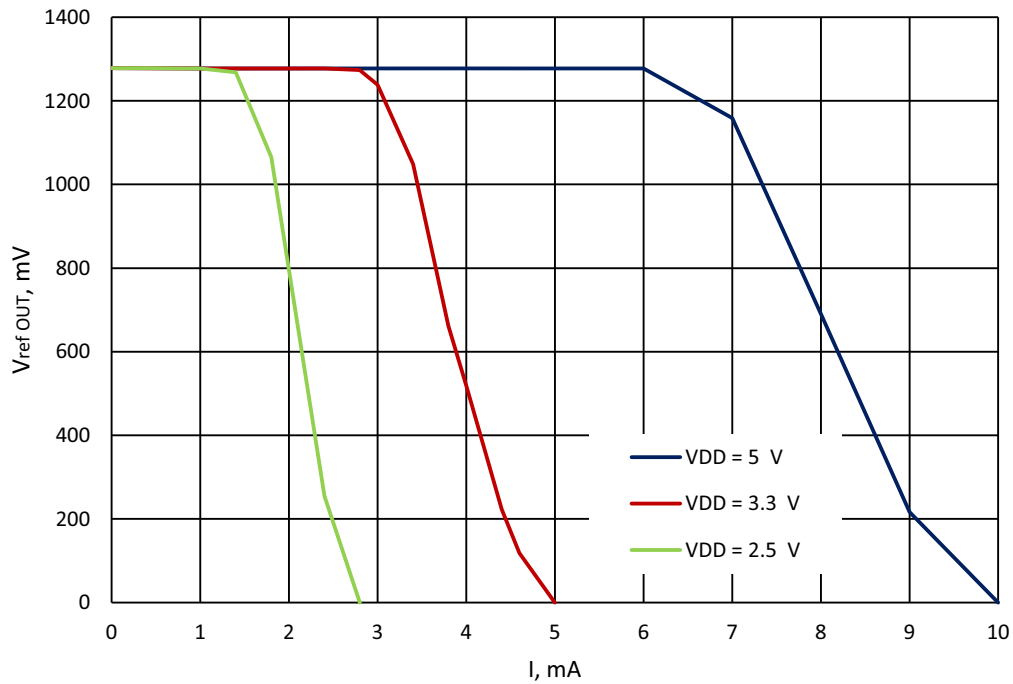

Figure 82: Typical Load Regulation, Vref = 1280 mV, T = -40 °C to +105 °C, Buffer - Enabled

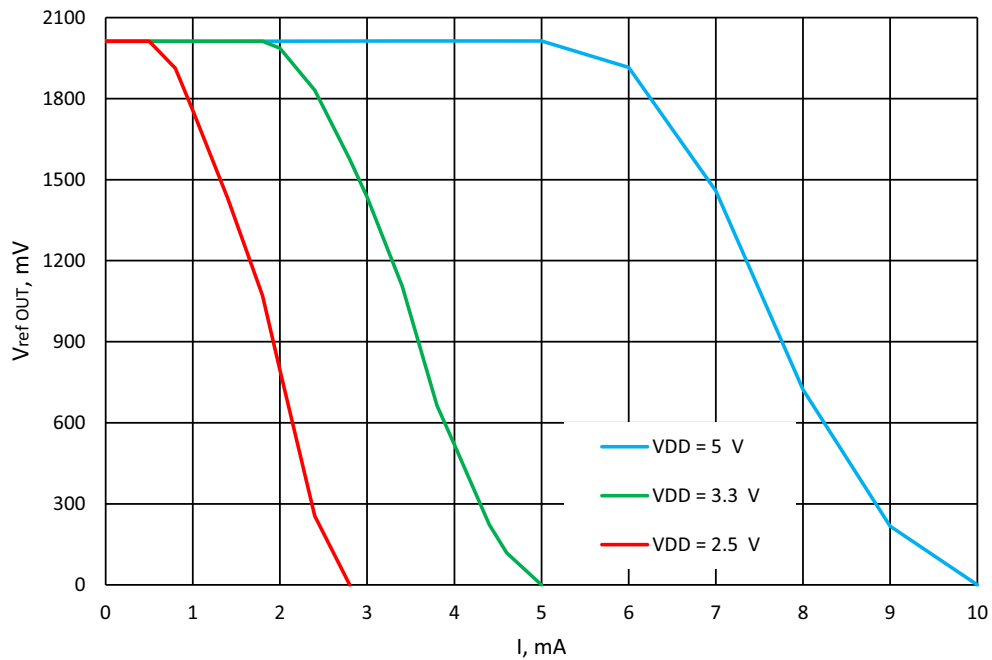

Figure 83: Typical Load Regulation, Vref = 2016 mV, T = -40 °C to +105 °C, Buffer - Enabled

# SLG46855-A

## Auto AEC-Q100 Qualified GreenPAK Programmable Mixed-Signal Matrix

### 13 Clocking

#### 13.1 OSC GENERAL DESCRIPTION

The SLG46855-A has three internal oscillators to support a variety of applications:

- Oscillator0 (2.048 kHz)
- Oscillator1 (2.048 MHz)
- Oscillator2 (25 MHz).

There are two divider stages for each oscillator that gives the user flexibility for introducing clock signals to connection matrix, as well as various other macrocells. The pre-divider (first stage) for Oscillator allows the selection of /1, /2, /4 or /8 to divide down frequency from the fundamental. The second stage divider has an input of frequency from the pre-divider, and outputs one of eight different frequencies divided by /1, /2, /3, /4, /8, /12, /24 or /64 on Connection Matrix Input lines [53], [54], and [55]. Please see [Figure 87](#) for more details on the SLG46855-A clock scheme.

Oscillator2 (25 MHz) has an additional function of 100 ns delayed startup, which can be enabled/disabled by register [749]. This function is recommended to use when analog blocks are used along with the Oscillator.

The Matrix Power-down/Force On function allows switching off or force on the oscillator using an external pin. The Matrix Power-down/Force On (Connection Matrix Output [80], [81], [82]) signal has the highest priority. The OSC operates according to the following table:

**Table 55: Oscillator Operation Mode Configuration Settings**

| POR | External Clock Selection | Signal From Connection Matrix | Register: Power-Down or Force On by Matrix Input | Register: Auto Power-On or Force On | OSC Enable Signal from CNT/DLY Macrocells | OSC Operation Mode               |
|-----|--------------------------|-------------------------------|--|-------------------------------------|---|----------------------------------|
| 0   | X                        | X                             | X  | X                                   | X   | OFF                              |
| 1   | 1                        | X                             | X  | X                                   | X   | Internal OSC is OFF, logic is ON |
| 1   | 0                        | 1                             | 0  | X                                   | X   | OFF                              |
| 1   | 0                        | 1                             | 1  | X                                   | X   | ON                               |
| 1   | 0                        | 0                             | X  | 1                                   | X   | ON                               |
| 1   | 0                        | 0                             | X  | 0                                   | CNT/DLY requires OSC                      | ON                               |
| 1   | 0                        | 0                             | X  | 0                                   | CNT/DLY does not require OSC              | OFF                              |

**Note 1** The OSC will run only when any macrocell that uses OSC is powered on.

SLG46855-A

Auto AEC-Q100 Qualified GreenPAK Programmable Mixed-Signal Matrix

13.2 OSCILLATOR0 (2.048 KHZ)

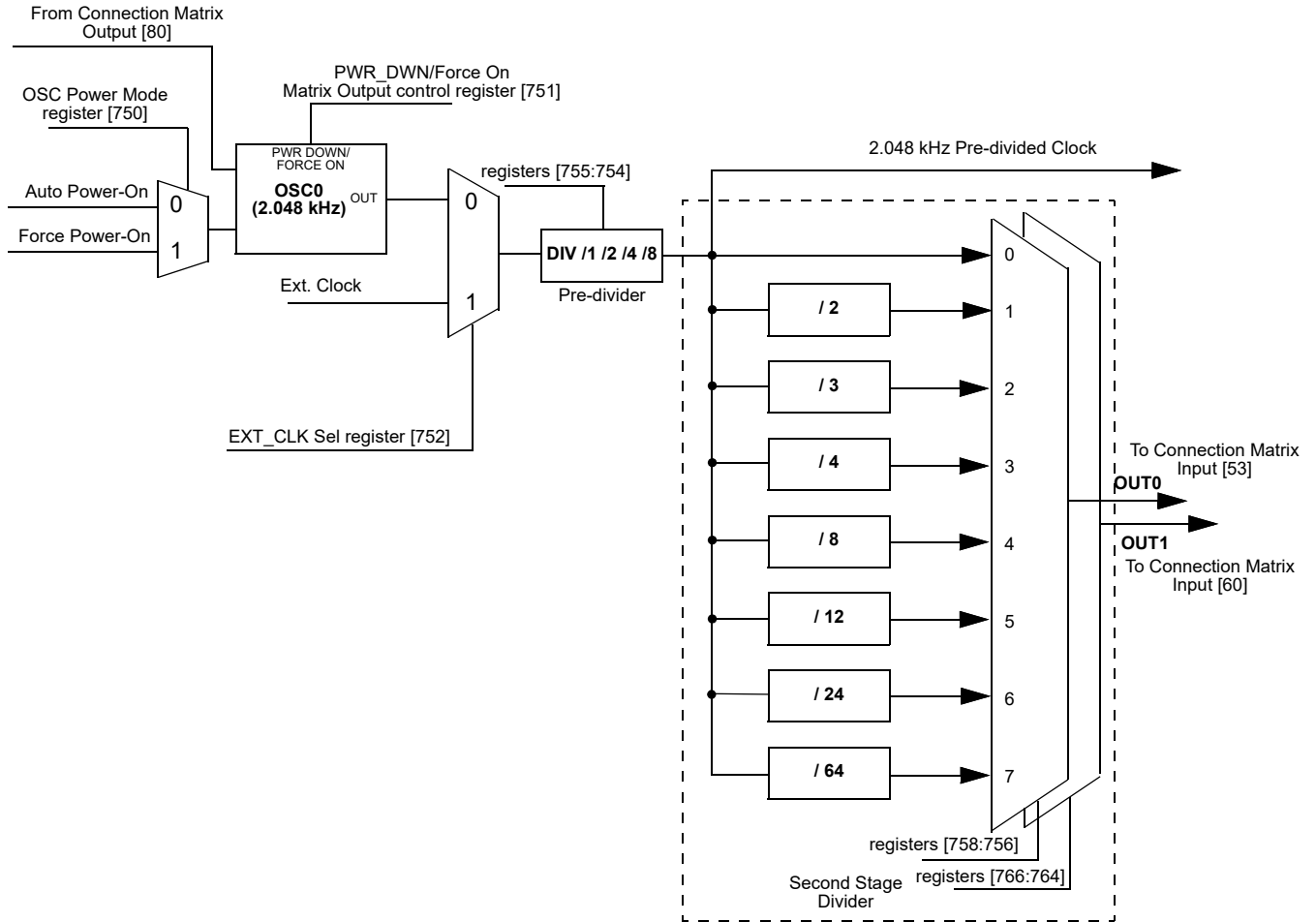

Figure 84: Oscillator0 Block Diagram



SLG46855-A

Auto AEC-Q100 Qualified GreenPAK Programmable Mixed-Signal Matrix

13.3 OSCILLATOR1 (2.048 MHZ)

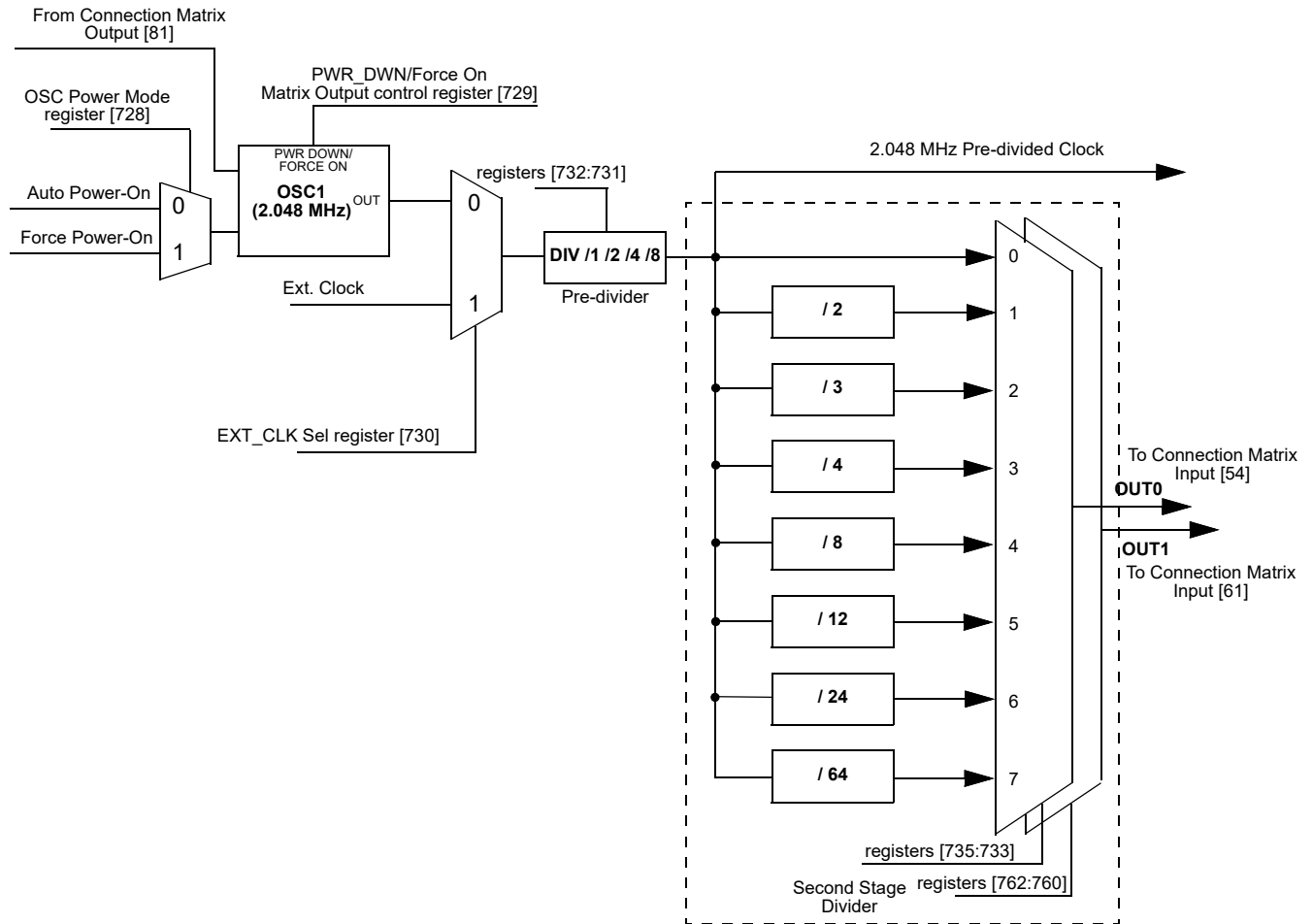

Figure 85: Oscillator1 Block Diagram

SLG46855-A

Auto AEC-Q100 Qualified GreenPAK Programmable Mixed-Signal Matrix

13.4 OSCILLATOR2 (25 MHZ)

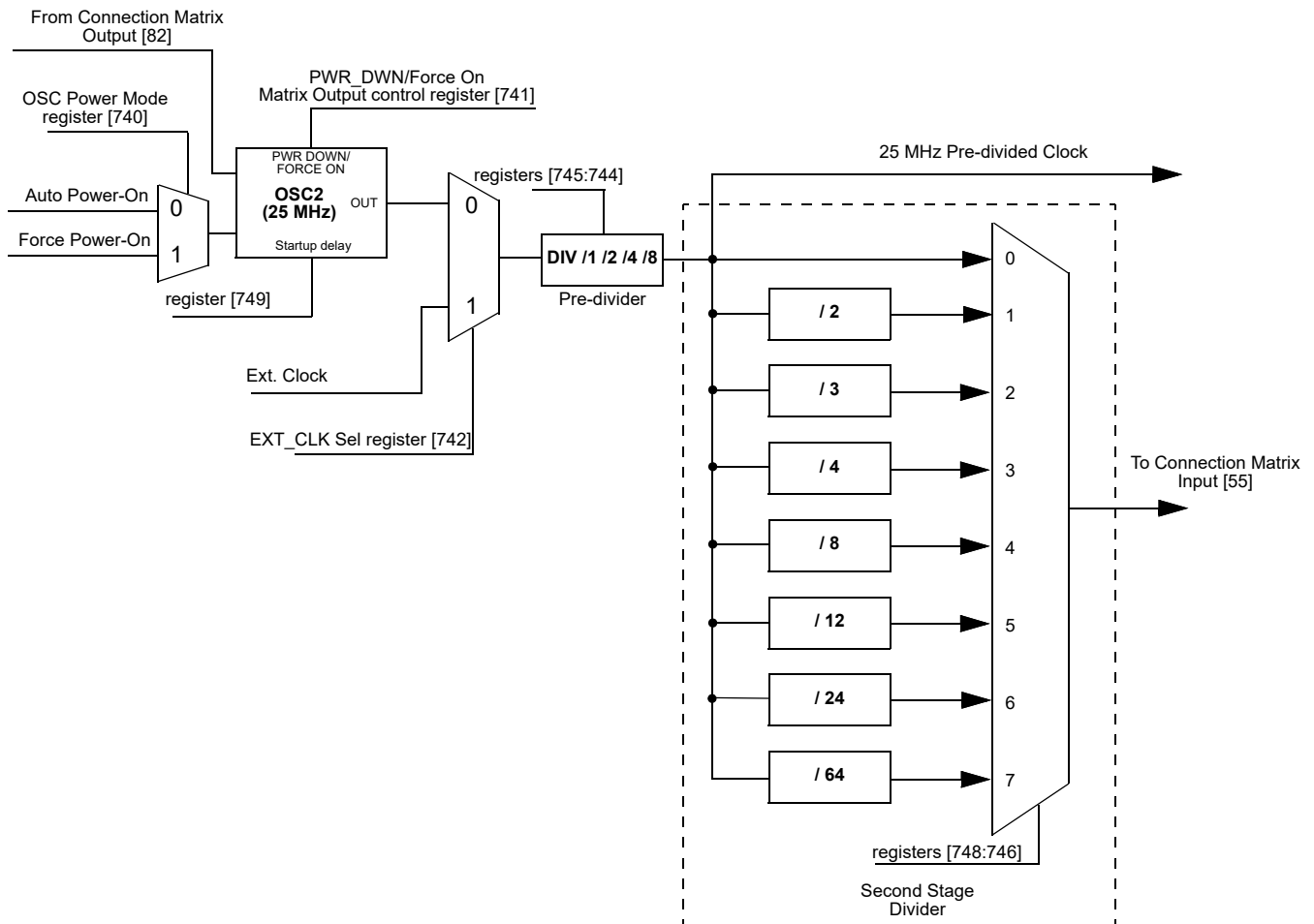

Figure 86: Oscillator2 Block Diagram

13.5 CNT/DLY CLOCK SCHEME

Each CNT/DLY within Multi-Function macrocell has its own additional clock divider connected to oscillators pre-divider. Available dividers are:

- OSC0/1, OSC0/8, OSC0/64, OSC0/512, OSC0/4096, OSC0/32768, OSC0/262144
- OSC1/1, OSC1/8, OSC1/64, OSC1/512
- OSC2/1, OSC2/4

SLG46855-A

Auto AEC-Q100 Qualified GreenPAK Programmable Mixed-Signal Matrix

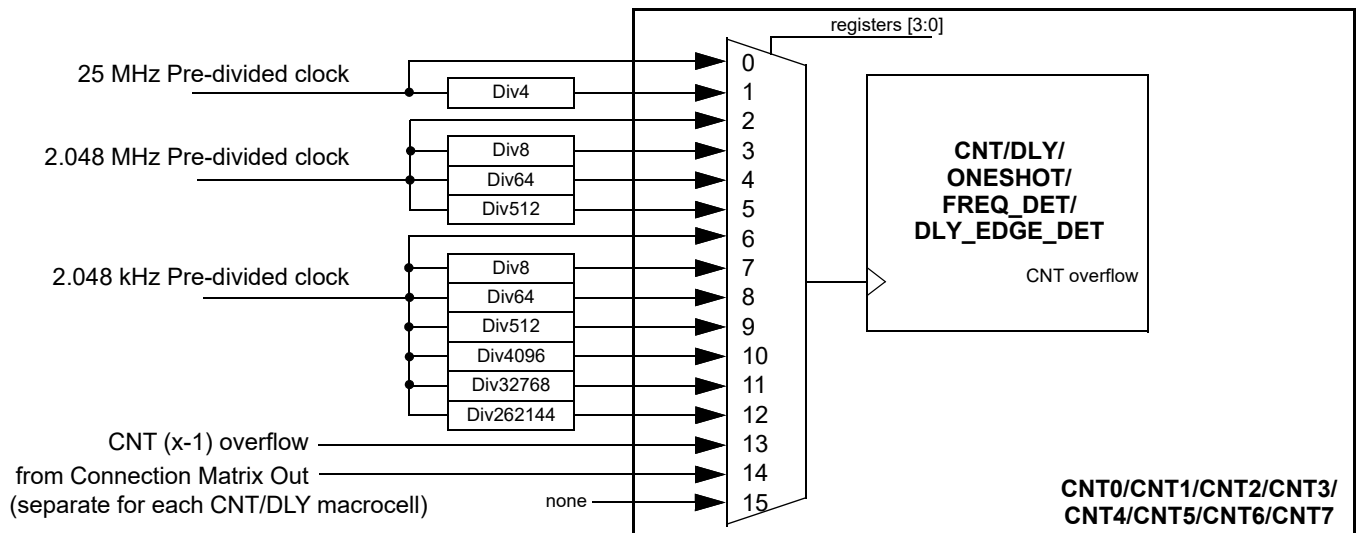

Figure 87: Clock Scheme

13.6 EXTERNAL CLOCKING

The SLG46855-A supports several ways to use an external, higher accuracy clock as a reference source for internal operations.

13.6.1 GPIO Source for Oscillator0 (2.048 kHz)

When register [752] is set to 1, an external clocking signal on GPIO will be routed in place of the internal oscillator derived 2.048 kHz clock source. See Figure 84. The low and high limits for external frequency that can be selected are 0 MHz and 10 MHz.

13.6.2 GPIO2 Source for Oscillator1 (2.048 MHz)

When register [730] is set to 1, an external clocking signal on GPIO2 will be routed in place of the internal oscillator derived 2.048 MHz clock source. See Figure 85. The low and high limits for external frequency that can be selected are 0 MHz and 10 MHz.

13.6.3 GPIO8 Source for Oscillator 2 (25 MHz)

When register [742] is set to 1, an external clocking signal on GPIO8 will be routed in place of the internal oscillator derived 25 MHz clock source. See Figure 86. The external frequency range is 0 MHz to 20 MHz at  $V_{DD} = 2.3\text{ V}$ , 30 MHz at  $V_{DD} = 3.3\text{ V}$ , 50 MHz at  $V_{DD} = 5.0\text{ V}$ . When an external clock is selected for OSC2, the oscillator's output signal will be inverted with respect to the GPIO8 input signal.

SLG46855-A

Auto AEC-Q100 Qualified GreenPAK Programmable Mixed-Signal Matrix

13.7 OSCILLATORS POWER-ON DELAY

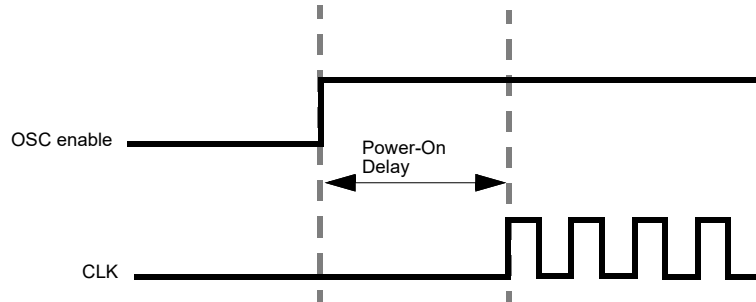

Figure 88: Oscillator Startup Diagram

**Note 1** OSC power mode: "Auto Power-On".

**Note 2** "OSC enable" signal appears when any macrocell that uses OSC is powered on.

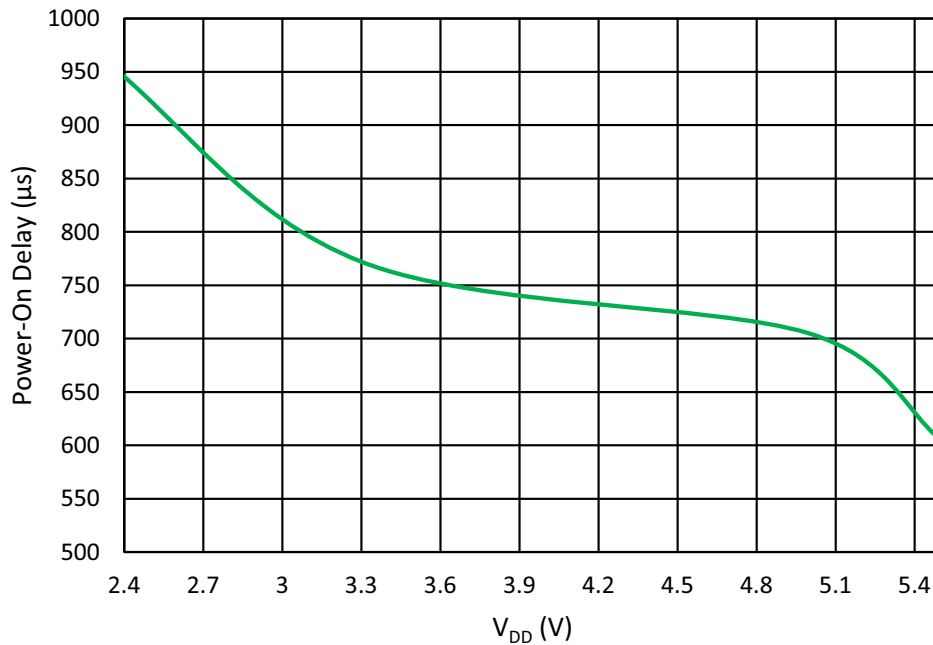

Figure 89: Oscillator0 Maximum Power-On Delay vs. V<sub>DD</sub> at T = 25 °C, OSC0 = 2.048 kHz

SLG46855-A

Auto AEC-Q100 Qualified GreenPAK Programmable Mixed-Signal Matrix

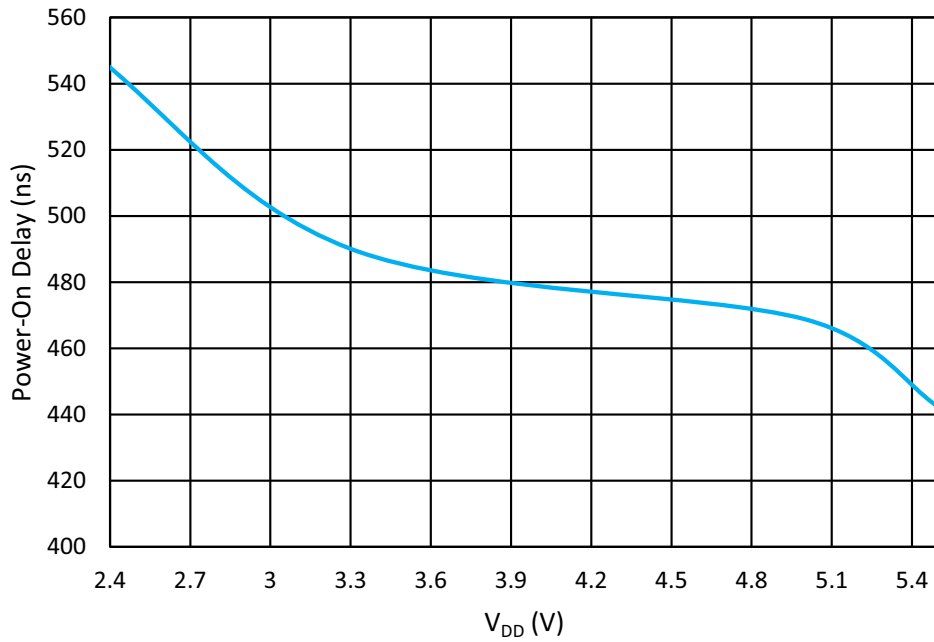

Figure 90: Oscillator1 Maximum Power-On Delay vs. V<sub>DD</sub> at T = 25 °C, OSC1 = 2.048 MHz

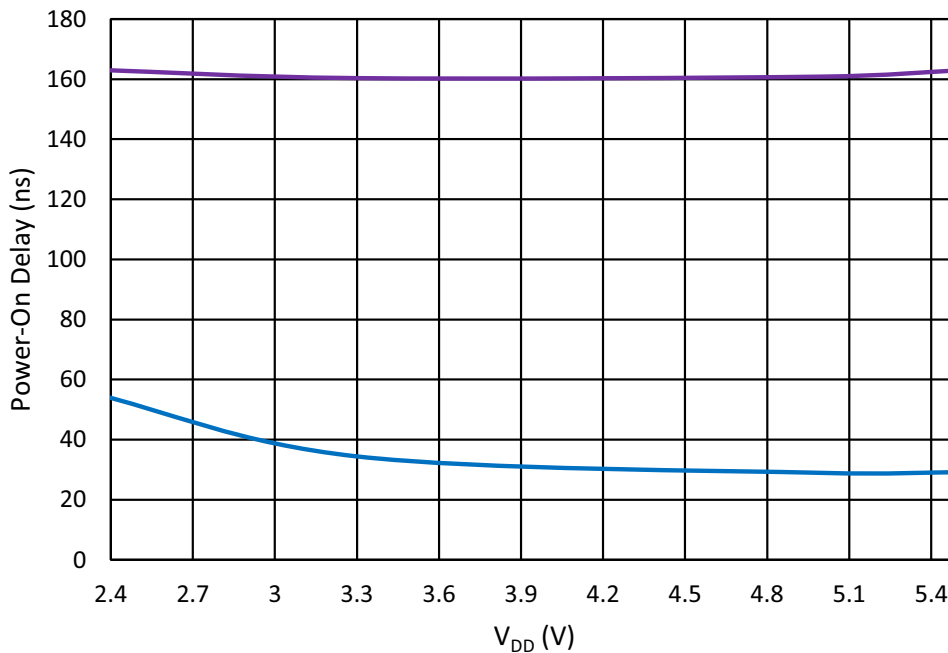

Figure 91: Oscillator2 Maximum Power-On Delay vs. V<sub>DD</sub> at T = 25 °C, OSC2 = 25 MHz

SLG46855-A

Auto AEC-Q100 Qualified GreenPAK Programmable Mixed-Signal Matrix

13.8 OSCILLATORS ACCURACY

Note: OSC power setting: Force Power-On; Clock to matrix input - enable; Bandgap: turn on by register - enable.

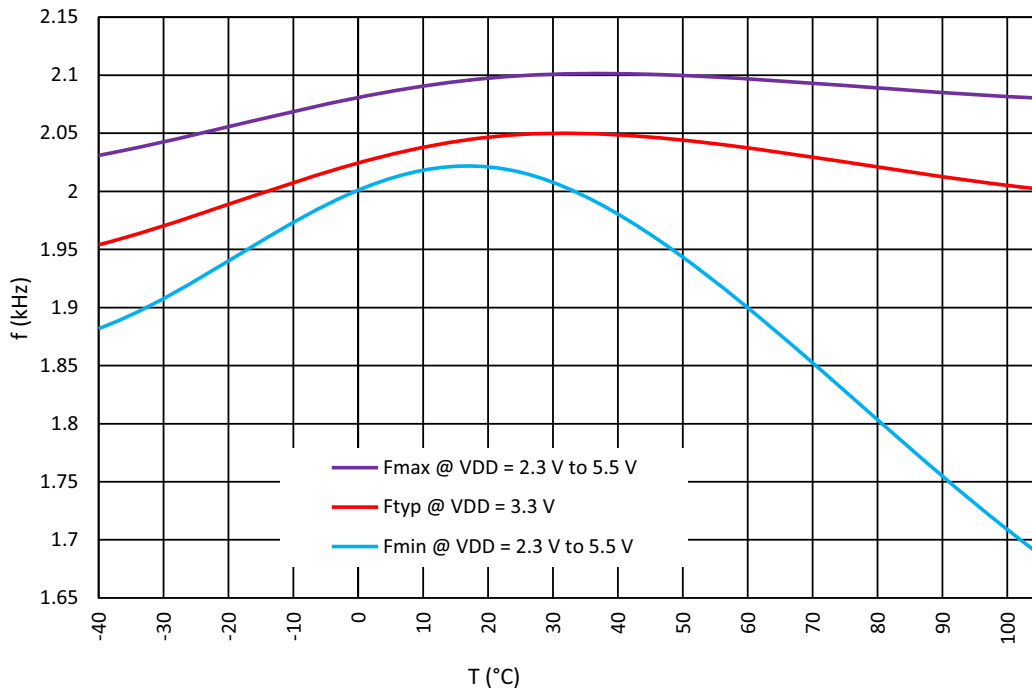

Figure 92: Oscillator0 Frequency vs. Temperature, OSC0 = 2.048 kHz

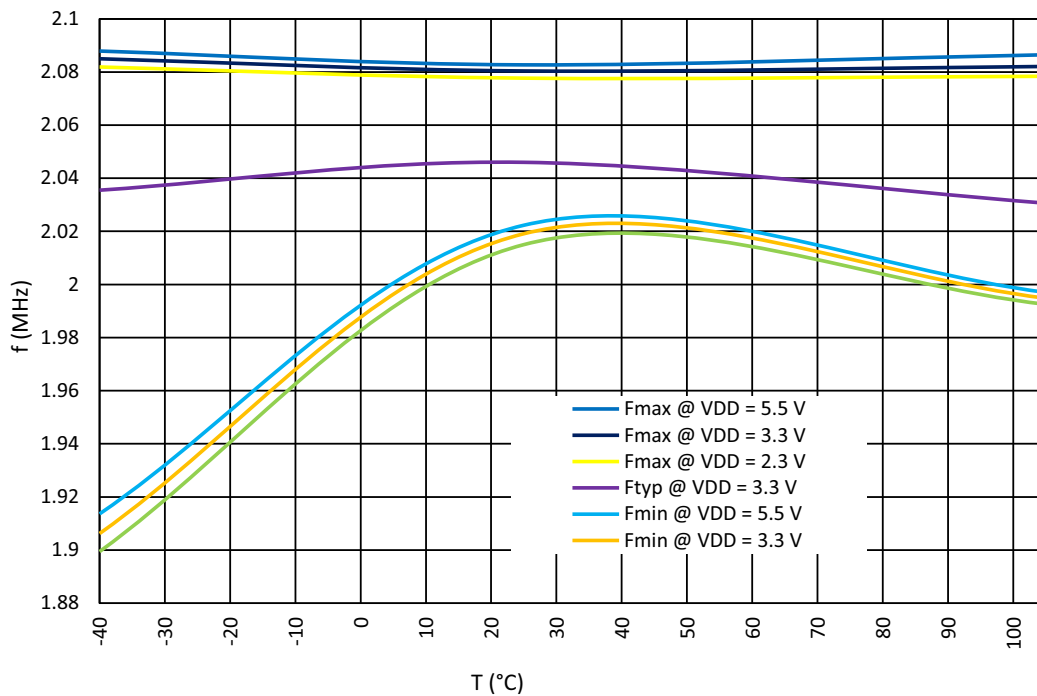

Figure 93: Oscillator1 Frequency vs. Temperature, OSC1 = 2.048 MHz

SLG46855-A

Auto AEC-Q100 Qualified GreenPAK Programmable Mixed-Signal Matrix

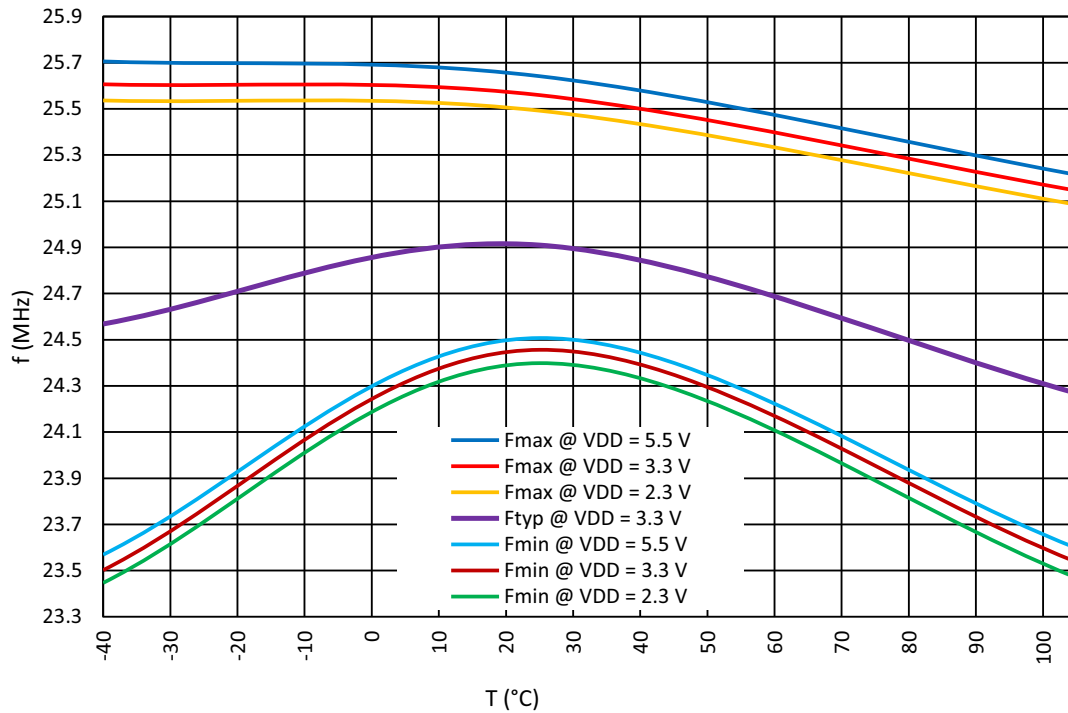

Figure 94: Oscillator2 Frequency vs. Temperature, OSC2 = 25 MHz

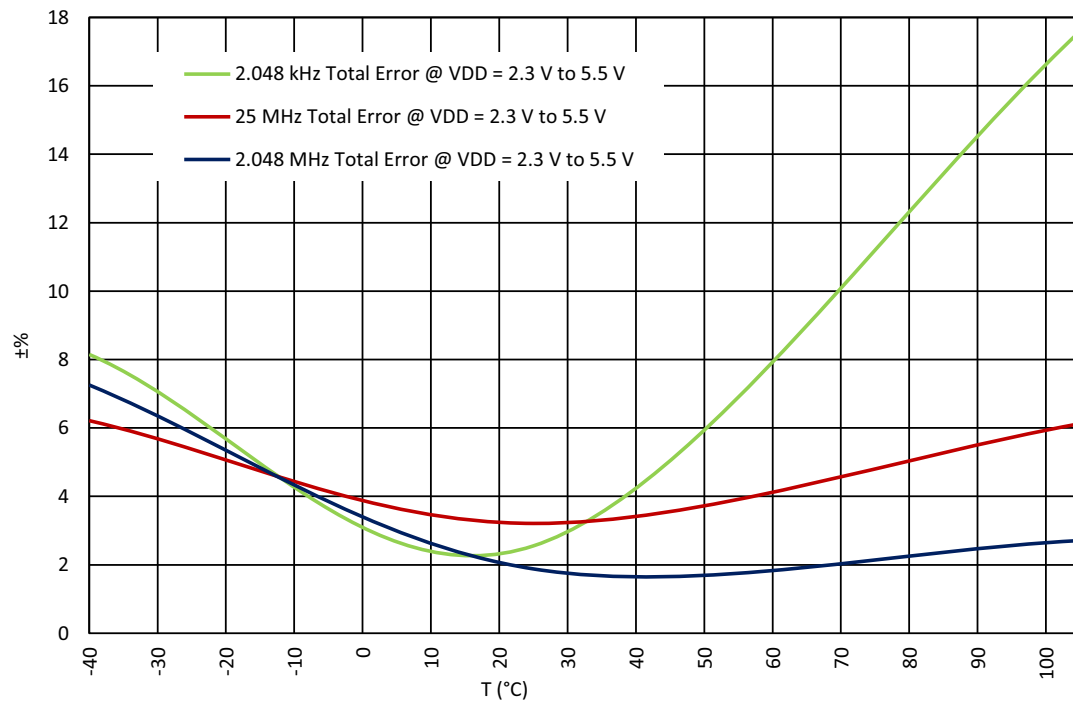

Figure 95: Oscillators Total Error vs. Temperature

Note: For more information see Section 3.9.

### 14 Power-On Reset

The SLG46855-A has a Power-On Reset (POR) macrocell to ensure correct device initialization and operation of all macrocells in the device. The purpose of the POR circuit is to have consistent behavior and predictable results when the  $V_{DD}$  power is first ramping to the device, and also while the  $V_{DD}$  is falling during Power-down. To accomplish this goal, the POR drives a defined sequence of internal events that trigger changes to the states of different macrocells inside the device, and finally to the state of the IOs.

#### 14.1 GENERAL OPERATION

The SLG46855-A is guaranteed to be powered down and non-operational when the  $V_{DD}$  voltage (voltage on PIN1) is less than Power-Off Threshold (see in [Table 6](#)), but not less than -0.6 V. Another essential condition for the chip to be powered down is that no voltage higher (Note) than the  $V_{DD}$  voltage is applied to any other PIN. For example, if  $V_{DD}$  voltage is 0.3 V, applying a voltage higher than 0.3 V to any other PIN is incorrect, and can lead to incorrect or unexpected device behavior.

**Note:** There is a 0.6 V margin due to forward drop voltage of the ESD protection diodes.

To start the POR sequence in the SLG46855-A, the voltage applied on the  $V_{DD}$  should be higher than the Power-On threshold (Note). The full operational  $V_{DD}$  range for the SLG46855-A is 2.3 V to 5.5 V. This means that the  $V_{DD}$  voltage must ramp up to the operational voltage value, but the POR sequence will start earlier, as soon as the  $V_{DD}$  voltage rises to the Power-On threshold. After the POR sequence has started, the SLG46855-A will have a typical period of time to go through all the steps in the sequence (noted in the datasheet for that device), and will be ready and completely operational after the POR sequence is complete.

**Note:** The Power-On threshold is defined in [Table 6](#).

To power down the chip the  $V_{DD}$  voltage should be lower than the operational and to guarantee that chip is powered down it should be less than Power-Off Threshold.

All PINs are in high impedance state when the chip is powered down and while the POR sequence is taking place. The last step in the POR sequence releases the IO structures from the high impedance state, at which time the device is operational. The pin configuration at this point in time is defined by the design programmed into the chip. Also, as it was mentioned before the voltage on PINs can't be bigger than the  $V_{DD}$ , this rule also applies to the case when the chip is powered on.



# SLG46855-A

## Auto AEC-Q100 Qualified GreenPAK Programmable Mixed-Signal Matrix

### 14.2 POR SEQUENCE

The POR system generates a sequence of signals that enable certain macrocells. The sequence is shown in [Figure 96](#).

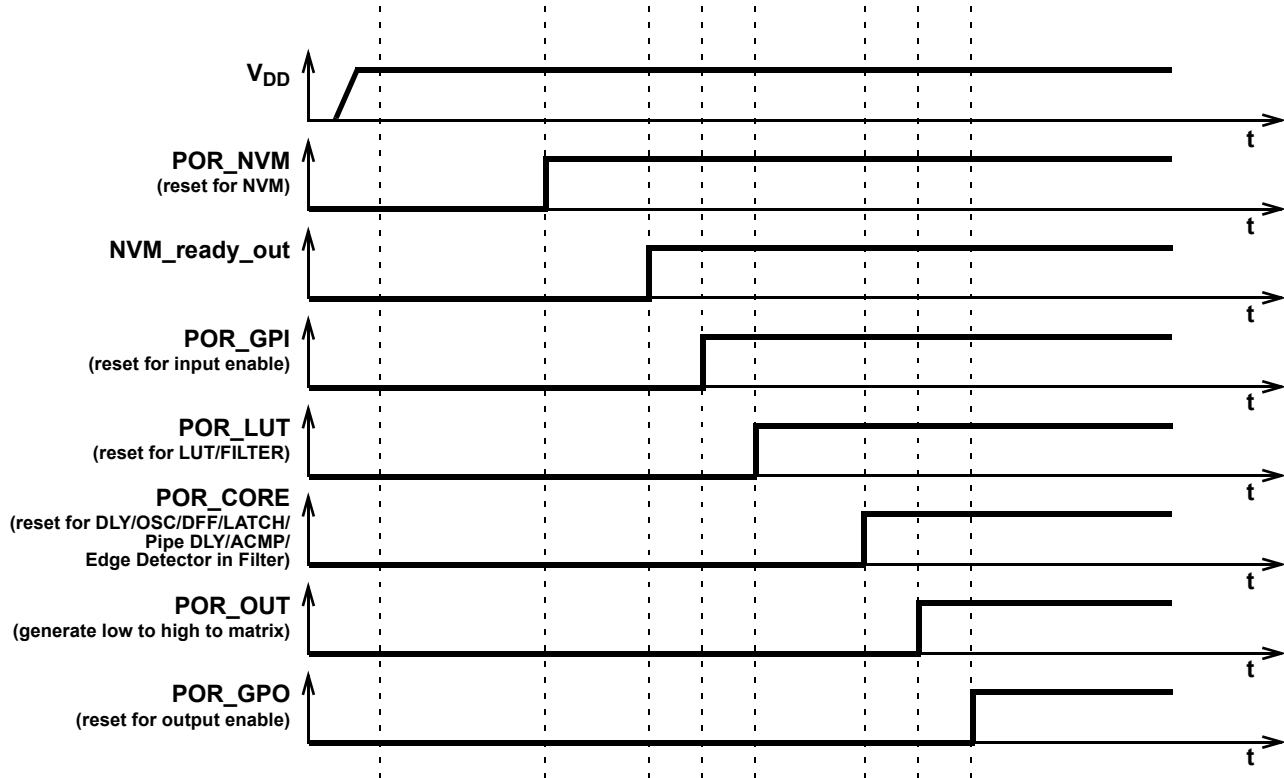

Figure 96: POR Sequence

As can be seen from [Figure 96](#) after the  $V_{DD}$  has start ramping up and crosses the Power-On threshold, first, the on-chip NVM memory is reset. Next, the chip reads the data from NVM, and transfers this information to a CMOS LATCH that serves to configure each macrocell, and the Connection Matrix which routes signals between macrocells. The third stage causes the reset of the input pins, and then to enable them. After that, the LUTs are reset and become active. After LUTs the Delay cells, OSCs, DFFs, LATCHES, and Pipe Delay are initialized. Only after all macrocells are initialized internal POR signal (POR macrocell output) goes from LOW to HIGH. The last portion of the device to be initialized are the output pins, which transition from high impedance to active at this point.

The typical time that takes to complete the POR sequence varies by device type in the GreenPAK family. It also depends on many environmental factors, such as: slew rate,  $V_{DD}$  value, temperature, and even will vary from chip to chip (process influence).

### 14.3 MACROCELLS OUTPUT STATES DURING POR SEQUENCE

To have a full picture of SLG46855-A operation during powering and POR sequence, review the overview the macrocell output states during the POR sequence ([Figure 97](#) describes the output signals states).

First, before the NVM has been reset, all macrocells have their output set to logic LOW (except the output pins which are in high impedance state). On the next step, some of the macrocells start initialization: input pins output state becomes LOW; LUTs also output LOW. Only P\_DLY macrocell configured as edge detector becomes active at this time. After that input pins are enabled.

# SLG46855-A

## Auto AEC-Q100 Qualified GreenPAK Programmable Mixed-Signal Matrix

Next, only LUTs are configured. Next, all other macrocells are initialized. After macrocells are initialized, internal POR matrix signal switches from LOW to HIGH. The last are output pins that become active and determined by the input signals.

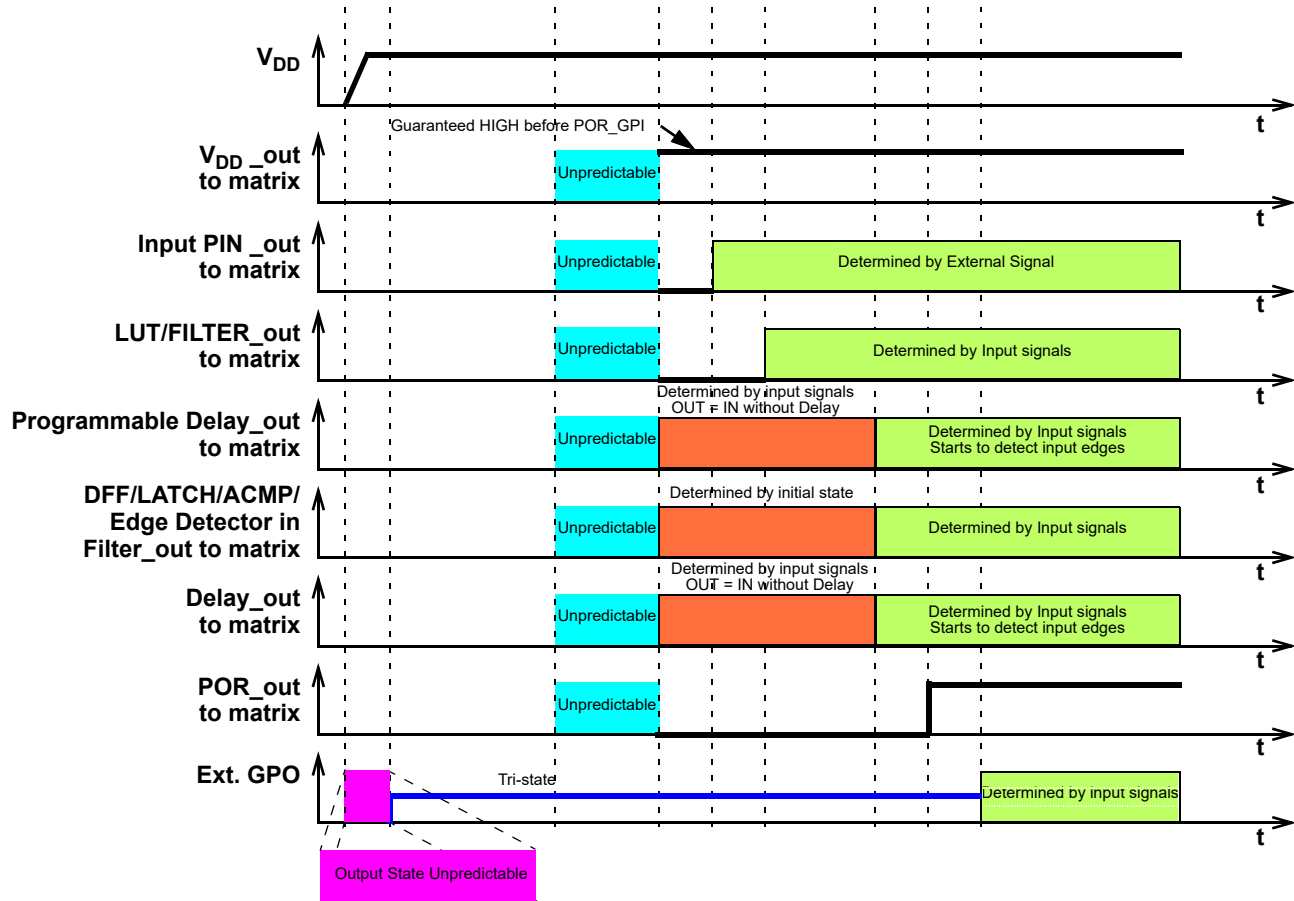

**Figure 97: Internal Macrocell States During POR Sequence**

### 14.3.1 Initialization

All internal macrocells by default have initial low level. Starting from indicated power-up time of 1.56 V to 2.03 V, macrocells in SLG46855-A are powered on while forced to the reset state. All outputs are in Hi-Z and chip starts loading data from NVM. Then the reset signal is released for internal macrocells and they start to initialize according to the following sequence:

1. Input pins, ACMP, Pull-up/down.
2. LUTs.
3. DFFs, Delays/Counters, Pipe Delay.
4. POR output to matrix.
5. Output pin corresponds to the internal logic.

The Vref output pin driving signal can precede POR output signal going high by 3 μs to 5 μs. The POR signal going high indicates the mentioned power-up sequence is complete.

**Note:** The maximum voltage applied to any pin should not be higher than the V<sub>DD</sub> level. There are ESD Diodes between pin → V<sub>DD</sub> and pin → GND on each pin. So, if the input signal applied to pin is higher than V<sub>DD</sub>, then current will sink through the diode to V<sub>DD</sub>. Exceeding V<sub>DD</sub> results in leakage current on the input pin, and V<sub>DD</sub> will be pulled up, following the voltage on the input pin. There is no effect from input pin when input voltage is applied at the same time as V<sub>DD</sub>.

SLG46855-A

Auto AEC-Q100 Qualified GreenPAK Programmable Mixed-Signal Matrix

14.3.2 Power-Down

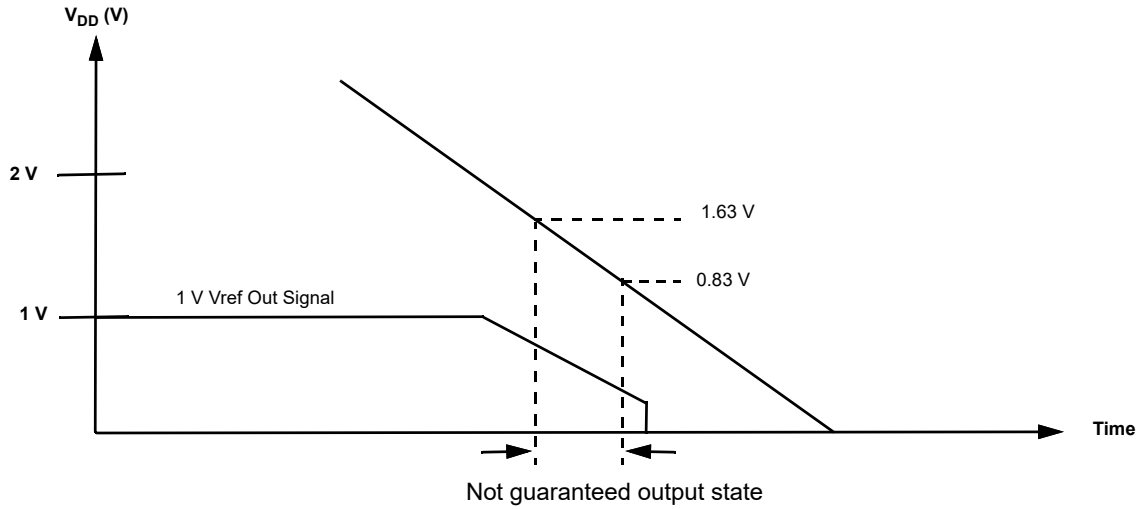

Figure 98: Power-Down

During power-down, macrocells in SLG46855-A are powered off after  $V_{DD}$  falling down below Power-Off Threshold. Please note that during a slow rampdown, outputs can possibly switch state during this time.

## 15 I<sup>2</sup>C Serial Communications Macrocell

### 15.1 I<sup>2</sup>C SERIAL COMMUNICATIONS MACROCELL OVERVIEW

In the standard use case for the GreenPAK devices, the configuration choices made by the user are stored as bit settings in the Non-Volatile Memory (NVM), and this information is transferred at startup time to volatile RAM registers that enable the configuration of the macrocells. Other RAM registers in the device are responsible for setting the connections in the Connection Matrix to route signals in the manner most appropriate for the user's application.

The I<sup>2</sup>C Serial Communications Macrocell in this device allows an I<sup>2</sup>C bus Master to read and write this information via a serial channel directly to the RAM registers, allowing the remote re-configuration of macrocells, and remote changes to signal chains within the device.

An I<sup>2</sup>C bus Master is also able to read and write other register bits that are not associated with NVM memory. As an example, the input lines to the Connection Matrix can be read as digital register bits. These are the signal outputs of each of the macrocells in the device, giving an I<sup>2</sup>C bus Master the capability to remotely read the current value of any macrocell.

The user has the flexibility to control read access and write access via registers bits registers [1967:1965]. See Section 15.5 for more details on I<sup>2</sup>C read/write memory protection.

### 15.2 I<sup>2</sup>C SERIAL COMMUNICATIONS DEVICE ADDRESSING

Each command to the I<sup>2</sup>C Serial Communications macrocell begins with a Control Byte. The bits inside this Control Byte are shown in Figure 99. After the Start bit, the first four bits are a control code. Each bit in a control code can be sourced independently from the register or by value defined externally GPIO0, GPIO2, GPIO4, and GPIO5. The LSB of the control code is defined by the value of GPIO0, while the MSB is defined by the value of GPIO5. The address source (either register bit or PIN) for each bit in the control code is defined by registers [2027:2024]. This gives the user flexibility on the chip level addressing of this device and other devices on the same I<sup>2</sup>C bus. The Block Address is the next three bits (A10, A9, A8), which will define the most significant bits in the addressing of the data to be read or written by the command. The last bit in the Control Byte is the R/W bit, which selects whether a read command or write command is requested, with a "1" selecting for a Read command, and a "0" selecting for a Write command. This Control Byte will be followed by an Acknowledge bit (ACK), which is sent by this device to indicate successful communication of the Control Byte data.

In the I<sup>2</sup>C-bus specification and user manual, there are two groups of eight addresses (0000 xxx and 1111 xxx) that are reserved for the special functions, such as a system General Call address. If the user of this device chooses to set the Control Code to either "1111" or "0000" in a system with other slave device, please consult the I<sup>2</sup>C-bus specification and user manual to understand the addressing and implementation of these special functions, to insure reliable operation.

In the read and write command address structure, there are a total of 11 bits of addressing, each pointing to a unique byte of information, resulting in a total address space of 2K bytes. Of this 2K byte address space, the valid addresses accessible to the I<sup>2</sup>C Macrocell on the SLG46855-A are in the range from 0 (0x00) to 255 (0xFF). The MSB address bits (A10, A9, and A8) will be "0" for all commands to the SLG46855-A.

With the exception of the Current Address Read command, all commands will have the Control Byte followed by the Word Address. Figure 99 shows this basic command structure.

SLG46855-A

Auto AEC-Q100 Qualified GreenPAK Programmable Mixed-Signal Matrix

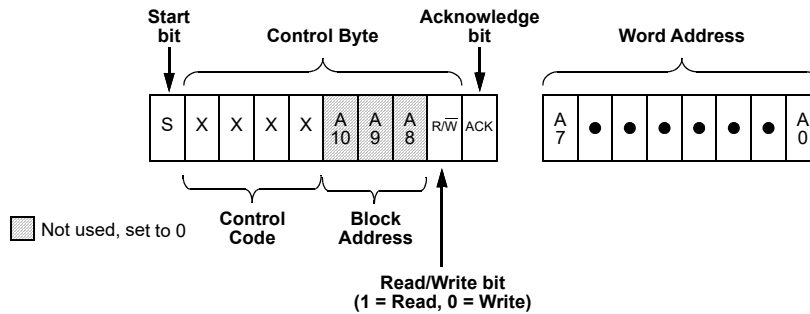

Figure 99: Basic Command Structure

15.3 I<sup>2</sup>C SERIAL GENERAL TIMING

General timing characteristics for the I<sup>2</sup>C Serial Communications macrocell are shown in Figure 100. Timing specifications can be found in the AC Characteristics section.

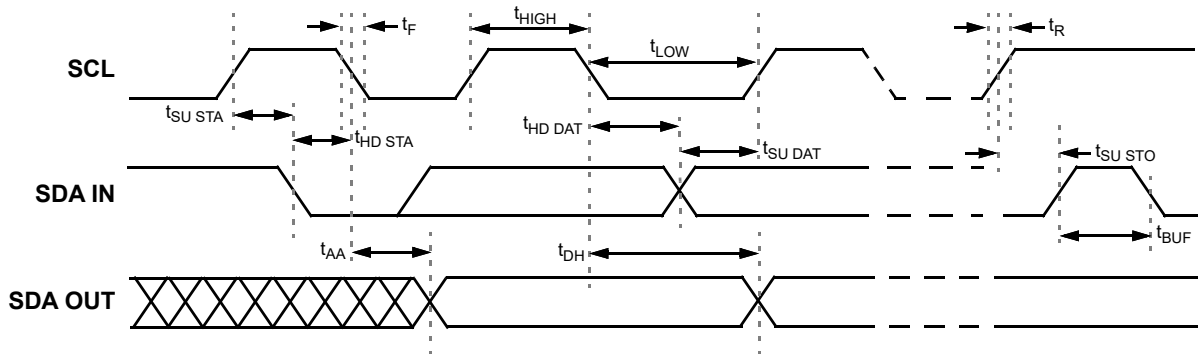

Figure 100: I<sup>2</sup>C General Timing Characteristics

15.4 I<sup>2</sup>C SERIAL COMMUNICATIONS COMMANDS

15.4.1 Byte Write Command

Following the Start condition from the Master, the Control Code [4 bits], the Block Address [3 bits], and the R/W bit (set to “0”) are placed onto the I<sup>2</sup>C bus by the Master. After the SLG46855-A sends an Acknowledge bit (ACK), the next byte transmitted by the Master is the Word Address. The Block Address (A10, A9, A8), combined with the Word Address (A7 through A0), together set the internal address pointer in the SLG46855-A, where the data byte is to be written. After the SLG46855-A sends another Acknowledge bit, the Master will transmit the data byte to be written into the addressed memory location. The SLG46855-A again provides an Acknowledge bit and then the Master generates a Stop condition. The internal write cycle for the data will take place at the time that the SLG46855-A generates the Acknowledge bit.

It is possible to latch all IOs during I<sup>2</sup>C write command, register [1961] = 1 - Enable. It means that IOs will remain their state until the write command is done.

SLG46855-A

Auto AEC-Q100 Qualified GreenPAK Programmable Mixed-Signal Matrix

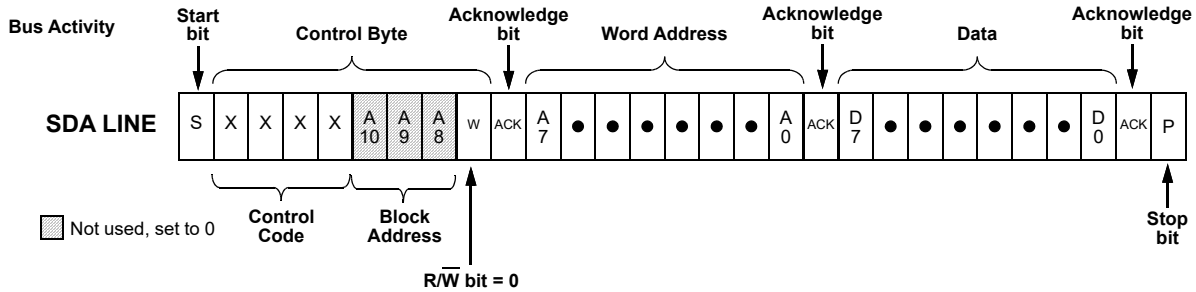

Figure 101: Byte Write Command,  $R/\overline{W} = 0$

15.4.2 Sequential Write Command

The write Control Byte, Word Address, and the first data byte are transmitted to the SLG46855-A in the same way as in a Byte Write command. However, instead of generating a Stop condition, the Bus Master continues to transmit data bytes to the SLG46855-A. Each subsequent data byte will increment the internal address counter, and will be written into the next higher byte in the command addressing. As in the case of the Byte Write command, the internal write cycle will take place at the time that the SLG46855-A generates the Acknowledge bit.

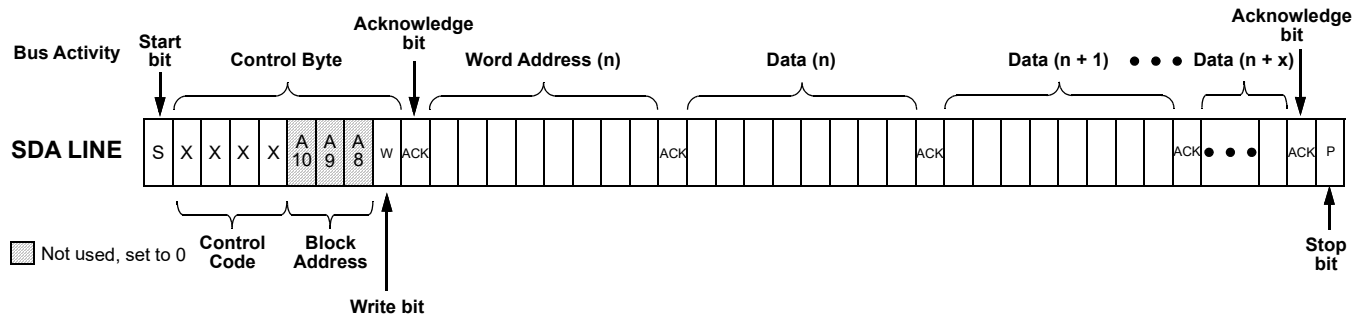

Figure 102: Sequential Write Command

15.4.3 Current Address Read Command

The Current Address Read Command reads from the current pointer address location. The address pointer is incremented at the first STOP bit following any write control byte. For example, if a Sequential Read command (which contains a write control byte) reads data up to address n, the address pointer would get incremented to n + 1 upon the STOP of that command. Subsequently, a Current Address Read that follows would start reading data at n + 1. The Current Address Read Command contains the Control Byte sent by the Master, with the  $R/\overline{W}$  bit = "1". The SLG46855-A will issue an Acknowledge bit, and then transmit eight data bits for the requested byte. The Master will not issue an Acknowledge bit, and follow immediately with a Stop condition.

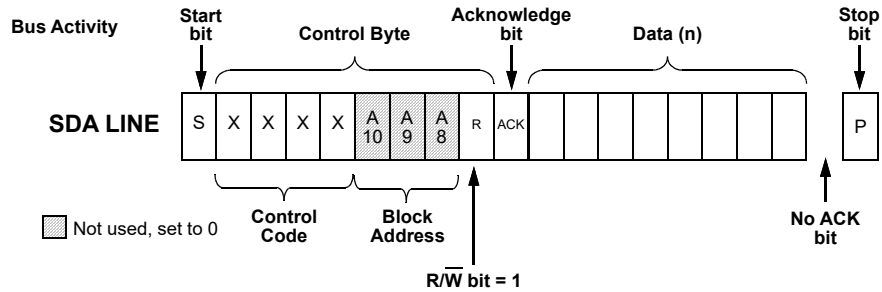

Figure 103: Current Address Read Command,  $\overline{R/W} = 1$

15.4.4 Random Read Command

The Random Read command starts with a Control Byte (with R/W bit set to “0”, indicating a write command) and Word Address to set the internal byte address, followed by a Start bit, and then the Control Byte for the read (exactly the same as the Byte Write command). The Start bit in the middle of the command will halt the decoding of a Write command, but will set the internal address counter in preparation for the second half of the command. After the Start bit, the Bus Master issues a second control byte with the R/W bit set to “1”, after which the SLG46855-A issues an Acknowledge bit, followed by the requested eight data bits.

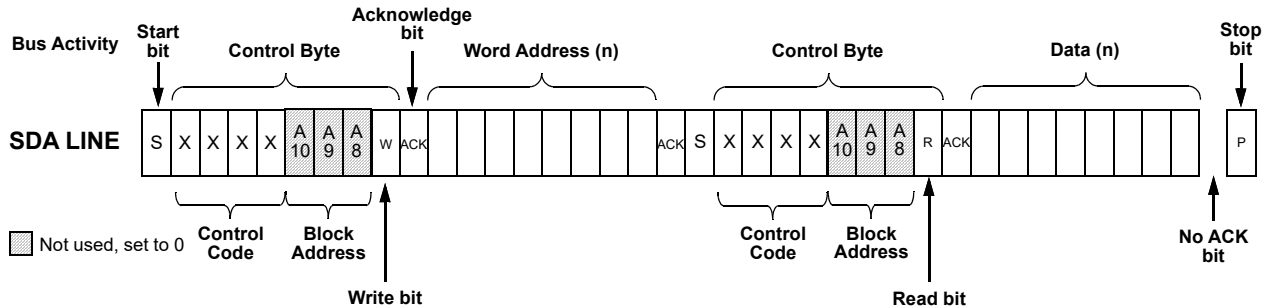

Figure 104: Random Read Command

SLG46855-A

Auto AEC-Q100 Qualified GreenPAK Programmable Mixed-Signal Matrix

15.4.5 Sequential Read Command

The Sequential Read command is initiated in the same way as a Random Read command, except that once the SLG46855-A transmits the first data byte, the Bus Master issues an Acknowledge bit as opposed to a Stop condition in a random read. The Bus Master can continue reading sequential bytes of data, and will terminate the command with a Stop condition.

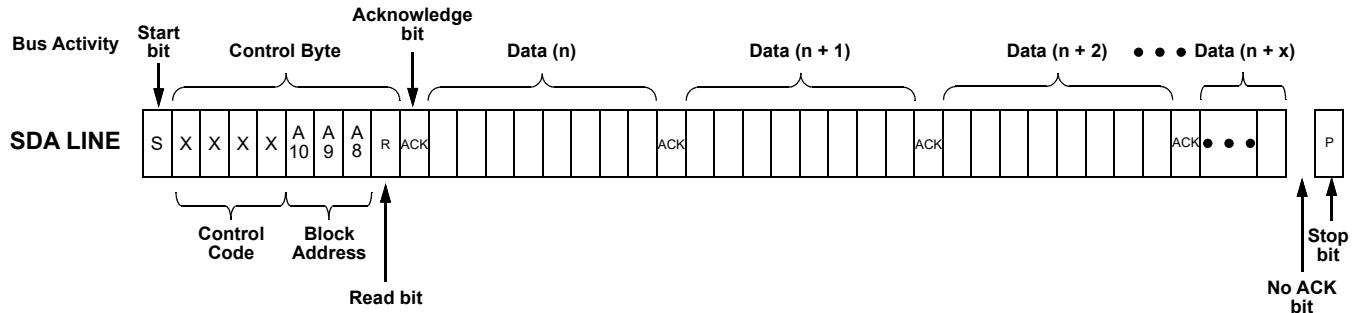

Figure 105: Sequential Read Command

15.4.6 I<sup>2</sup>C Serial Reset Command

If I<sup>2</sup>C serial communication is established with the device, it is possible to reset the device to initial power up conditions, including configuration of all macrocells, and all connections provided by the Connection Matrix. This is implemented by setting register [1960] I<sup>2</sup>C reset bit to “1”, which causes the device to re-enable the Power-On Reset (POR) sequence, including the reload of all register data from NVM. During the POR sequence, the outputs of the device will be in tri-state. After the reset has taken place, the contents of register [1960] will be set to “0” automatically. The Figure 106 illustrates the sequence of events for this reset function.

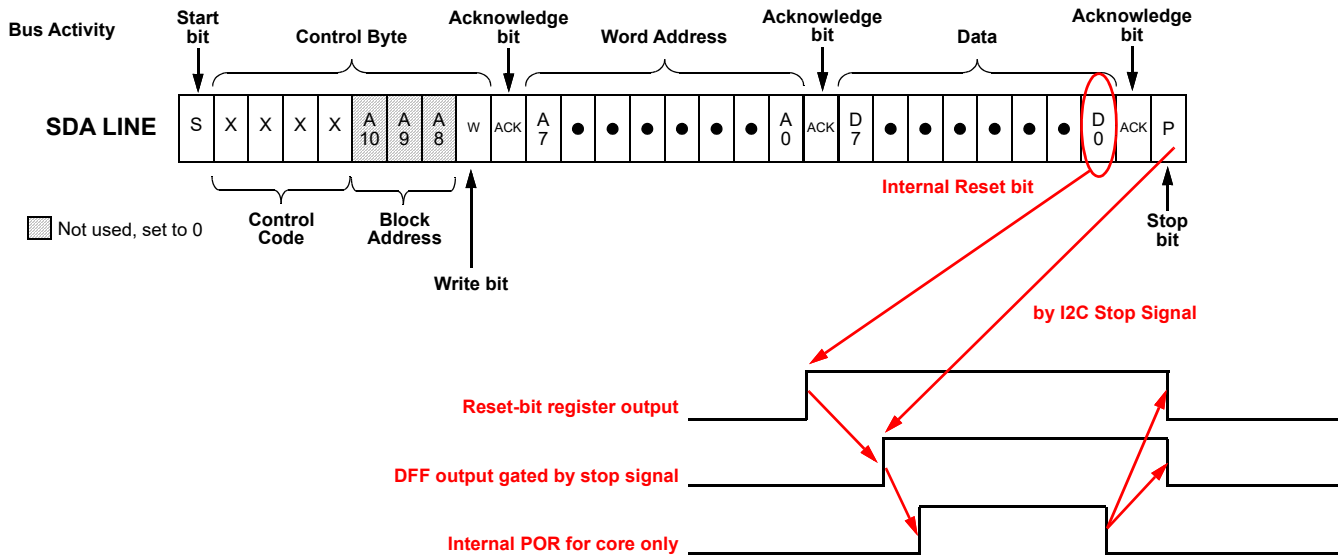

Figure 106: Reset Command Timing



**Auto AEC-Q100 Qualified GreenPAK Programmable Mixed-Signal Matrix**
**15.5 I<sup>2</sup>C SERIAL COMMAND REGISTER MAP**

There are seven read/write protect modes for the design sequence from being corrupted or copied. See [Table 55](#) for details.

**Table 56: Read/Write Protection Options**

| Configurations   | Protection Modes Configuration |                   |                   |                         |           |            |                 | Data Output From | Register Address |
|--|--------------------------------|-------------------|-------------------|-------------------------|-----------|------------|-----------------|------------------|------------------|
|  | Unlocked                       | Partly Lock Read1 | Partly Lock Read2 | Partly Lock Read2/Write | Lock Read | Lock Write | Lock Read/Write |                  |                  |
|  | (Mode 0)                       | (Mode 1)          | (Mode 2)          | (Mode 3)                | (Mode 4)  | (Mode 5)   | (Mode 6)        |                  |                  |
| I <sup>2</sup> C Byte Write Bit Masking (section 15.6.3)                                     | R/W                            | R/W               | R/W               | R/W                     | W         | R          | -               | Memory           | F6               |
| I <sup>2</sup> C Serial Reset Command (section 15.4.6)                                       | R/W                            | R/W               | R/W               | R/W                     | W         | R          | -               | Memory           | F5,b'0           |
| Outputs Latching During I <sup>2</sup> C Write   | R/W                            | R/W               | R/W               | R/W                     | W         | R          | -               | Memory           | F5,b'1           |
| Connection Matrix Virtual Inputs (section 6.3)   | R/W                            | R/W               | R/W               | R/W                     | W         | R          | -               | Macrocell        | 4C               |
| Configuration Bits for All Macrocells (IO Pins, ACMs, Combination Function Macrocells, etc.) | R/W                            | R/W               | W                 | -                       | W         | R          | -               | Memory           |                  |
| Macrocells Inputs Configuration (Connection Matrix Outputs, section 6.2)                     | R/W                            | W                 | W                 | -                       | W         | R          | -               | Memory           | 0~47             |
| Protection Mode Enable   | R                              | R                 | R                 | R                       | R         | R          | R               | Memory           | F5,b'3           |
| Protection Mode Selection  | R/W                            | R                 | R                 | R                       | R         | R          | R               | Memory           | F5,b'7~5         |
| Macrocells Output Values (Connection Matrix Inputs, section 6.1)                             | R                              | R                 | R                 | R                       | -         | R          | -               | Macrocell        | 48~4B;<br>4D~4F  |
| Counter Current Value (for 16-bit CNT)   | R                              | R                 | R                 | R                       | -         | R          | -               | Macrocell        | A5,A6            |
| Counter Current Value (for 8-bit CNT)  | R                              | R                 | R                 | R                       | -         | R          | -               | Macrocell        | A7,A8            |
| I <sup>2</sup> C Control Code (section 15.2)   | R                              | R                 | R                 | R                       | R         | R          | R               | Memory           | FD,b'3~0         |
| Pin Slave Address Select   | R                              | R                 | R                 | R                       | R         | R          | R               | Memory           | FD,b'7~4         |
| I <sup>2</sup> C Disable/Enable  | R                              | R                 | R                 | R                       | R         | R          | R               | Memory           | FE,b'0           |

## Auto AEC-Q100 Qualified GreenPAK Programmable Mixed-Signal Matrix

|     |  |
|-----|--|
| R/W | Allow Read and Write Data                |
| W   | Allow Write Data Only                    |
| R   | Allow Read Data Only                     |
| -   | The Data is protected for Read and Write |

It is possible to read some data from macrocells, such as counter current value, connection matrix, and connection matrix virtual inputs. The I<sup>2</sup>C write will not have any impact on data in case data comes from macrocell output, except Connection Matrix Virtual Inputs. The silicon identification service bits allows identifying silicon family, its revision, and others.

See Section 17 for detailed information on all registers.

### 15.6 I<sup>2</sup>C ADDITIONAL OPTIONS

When Output latching during I<sup>2</sup>C write, register [1961] = 1 allows all PINs output value to be latched until I<sup>2</sup>C write is done. It will protect the output change due to configuration process during I<sup>2</sup>C write in case multiple register bytes are changed. Inputs and internal macrocells retain their status during I<sup>2</sup>C write.

If the user sets GPIO0 and GPIO1 function to a selection other than SDA and SCL, all access via I<sup>2</sup>C will be disabled.

**Note:** Any write commands that come to the device via I<sup>2</sup>C that are not blocked, based on the protection bits, will change the contents of the RAM register bits that mirror the NVM bits. These write commands will not change the NVM bits themselves, and a POR event will restore the register bits to original programmed contents of the NVM.

See Section 17 for detailed information on all registers.

#### 15.6.1 Reading Counter Data via I<sup>2</sup>C

The current count value in three counters in the device can be read via I<sup>2</sup>C. The counters that have this additional functionality are 16-bit CNT0, and 8-bit counters CNT6 and CNT7.

#### 15.6.2 I<sup>2</sup>C Expander

In addition to the eight Connection Matrix Virtual Inputs, the SLG46855-A chip has four pins which can be used as an I<sup>2</sup>C Expander. These four pins are GPO0, GPIO6, GPIO7, and GPIO8.

Each of these pins can be used as an I<sup>2</sup>C Expander output or used as a normal pin. Also, each of these four expander outputs have initial state settings which are specified in registers [1959:1952].

# SLG46855-A

## Auto AEC-Q100 Qualified GreenPAK Programmable Mixed-Signal Matrix

### 15.6.3 I<sup>2</sup>C Byte Write Bit Masking

The I<sup>2</sup>C macrocell inside SLG46855-A supports masking of individual bits within a byte that is written to the RAM memory space. This function is supported across the entire RAM memory space. To implement this function, the user performs a Byte Write Command (see Section 15.4.1 for details) on the I<sup>2</sup>C Byte Write Mask Register (address 0F6H) with the desired bit mask pattern. This sets a bit mask pattern for the target memory location that will take effect on the next Byte Write Command to this register byte. Any bit in the mask that is set to “1” in the I<sup>2</sup>C Byte Write Mask Register will mask the effect of changing that particular bit in the target register, during the next Byte Write Command. The contents of the I<sup>2</sup>C Byte Write Mask Register are reset (set to 00h) after valid Byte Write Command. If the next command received by the device is not a Byte Write Command, the effect of the bit masking function will be aborted, and the I<sup>2</sup>C Byte Write Mask Register will be reset with no effect. Figure 107 shows an example of this function.

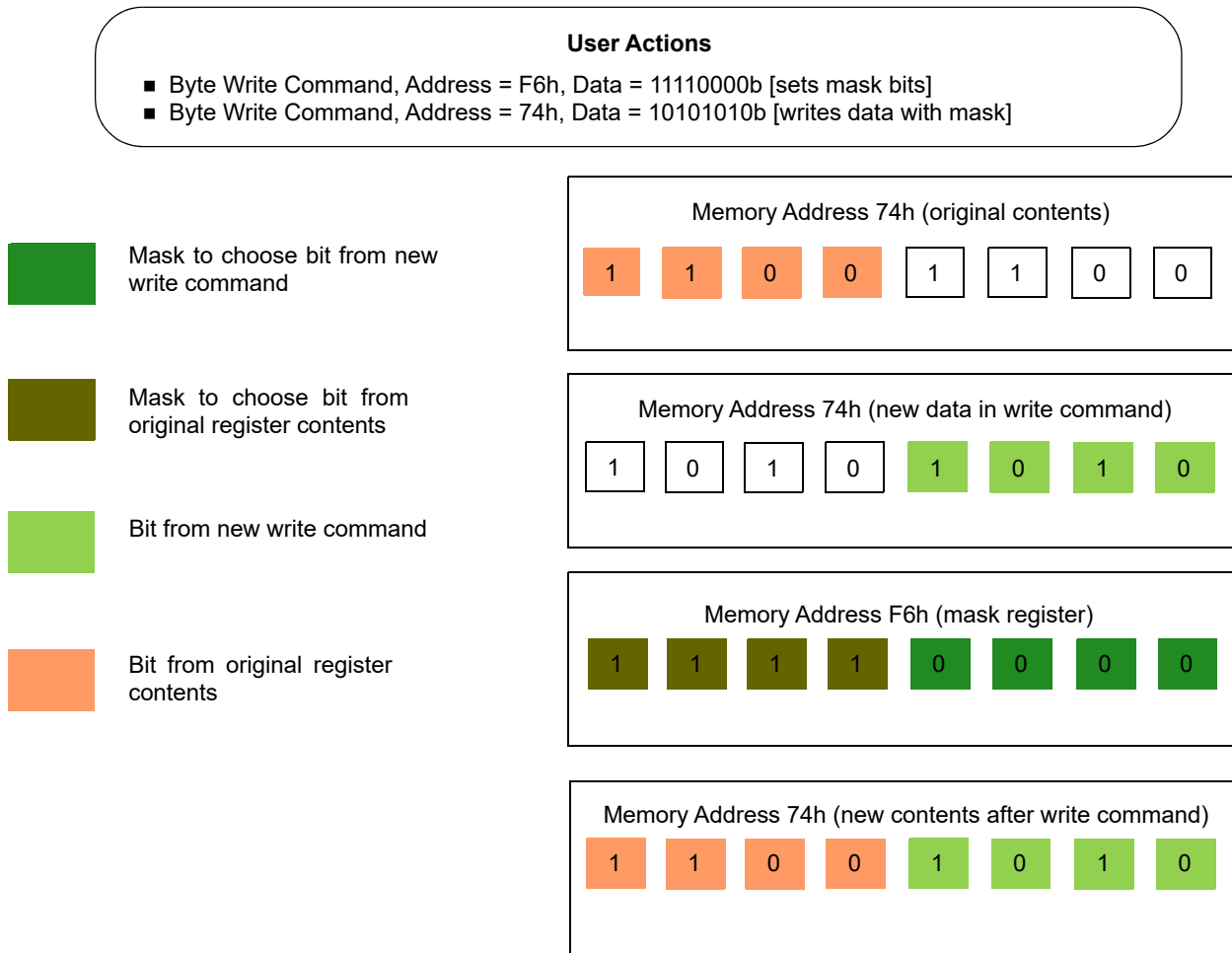

Figure 107: Example of I<sup>2</sup>C Byte Write Bit Masking

## 16 Analog Temperature Sensor

The SLG46855-A has an Analog Temperature sensor (TS) with an output voltage linearly-proportional to the Centigrade temperature. The TS cell shares buffer with Vref 0, so it is impossible to use both cells simultaneously, its output can be connected directly to the GPIO8 or to the ACPM3\_L positive input. Using buffer causes low-output impedance, linear output, and makes interfacing to readout or control circuitry especially easy. The TS is rated to operate over a -40 °C to 105 °C temperature range. The error in the whole temperature range does not exceed ±1.5 %. For more detail refer to section 3.11.

The equation below calculates the typical analog voltage passed from the TS to the ACMPs' IN+ source input for  $V_{DD} = 2.3\text{ V}$  to 5.5 V. It is important to note that there will be a chip to chip variation of about ±2 °C.

$$V_{TS1} = -2.3 \times T + 906.2$$

$$V_{TS2} = -2.8 \times T + 1094.3$$

where:

$V_{TS1}$  (mV) - TS Output Voltage, range 1

$V_{TS2}$  (mV) - TS Output Voltage, range 2

T (°C) - Temperature

Temperature hysteresis can be setup by enabling the GreenPAK's internal ACMP hysteresis.

SLG46855-A

Auto AEC-Q100 Qualified GreenPAK Programmable Mixed-Signal Matrix

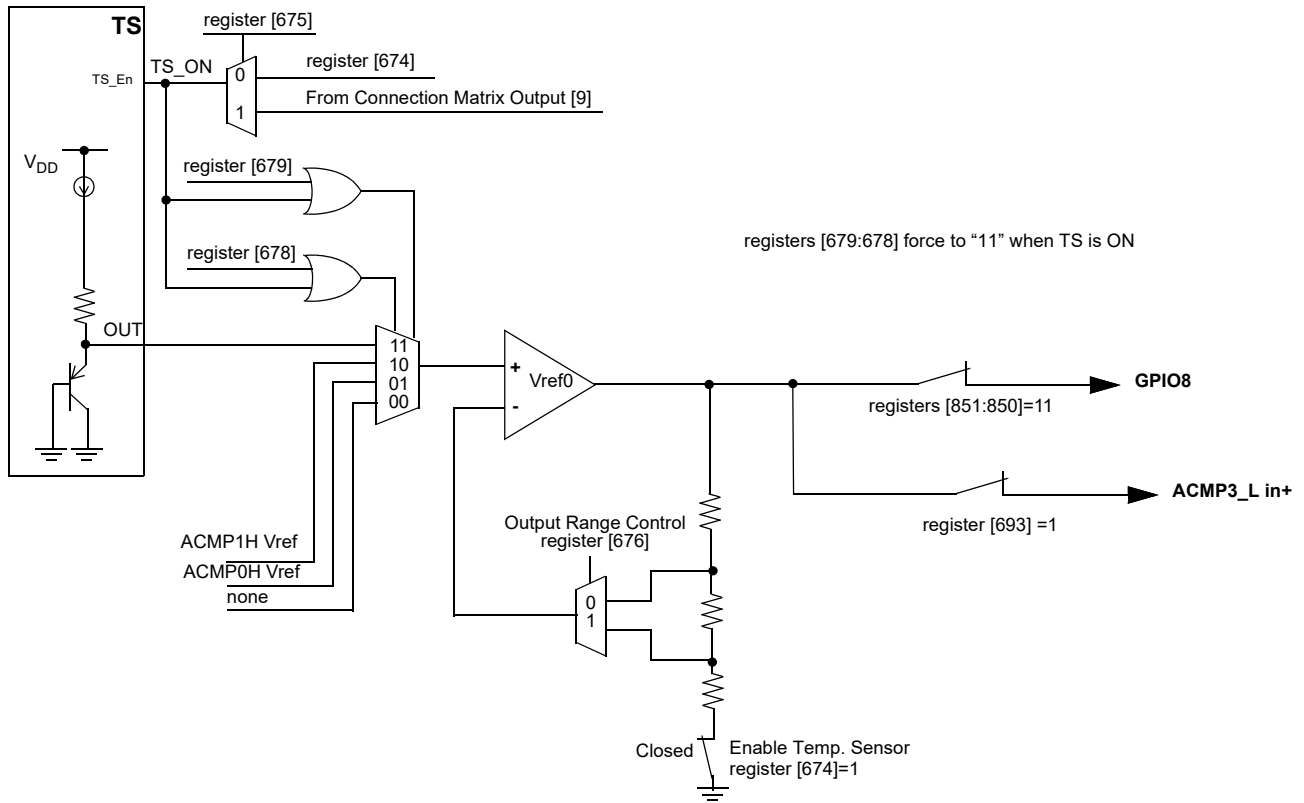

Figure 108: Analog Temperature Sensor Structure Diagram

SLG46855-A

Auto AEC-Q100 Qualified GreenPAK Programmable Mixed-Signal Matrix

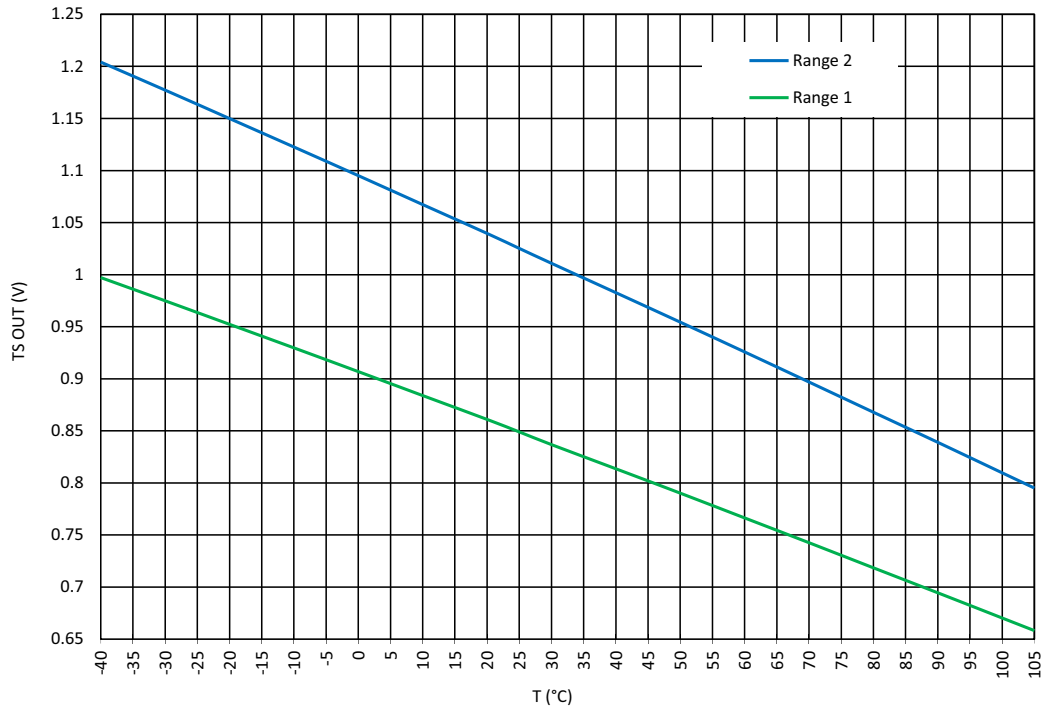

Figure 109: TS Output vs. Temperature,  $V_{DD} = 2.3\text{ V to }5.5\text{ V}$

# SLG46855-A

## Auto AEC-Q100 Qualified GreenPAK Programmable Mixed-Signal Matrix

### 17 Register Definitions

#### 17.1 REGISTER MAP

Table 57: Register Map

| Address              |              | Signal Function | Register Bit Definition                       |
|----------------------|--------------|-----------------|---|
| Byte                 | Register Bit |                 |   |
| <b>Matrix Output</b> |              |                 |   |
| 0                    | 0            | LUT2_0 & DFF0   | OUT0:<br>IN0 of LUT2_0 or Clock Input of DFF0 |
|                      | 1            |                 |   |
|                      | 2            |                 |   |
|                      | 3            |                 |   |
|                      | 4            |                 |   |
|                      | 5            |                 |   |
|                      | 6            |                 |   |
|                      | 7            |                 |   |
| 1                    | 8            | LUT2_1 & DFF1   | OUT1<br>IN1 of LUT2_0 or Data Input of DFF0   |
|                      | 9            |                 |   |
|                      | 10           |                 |   |
|                      | 11           |                 |   |
|                      | 12           |                 |   |
|                      | 13           |                 |   |
|                      | 14           |                 |   |
|                      | 15           |                 |   |
| 2                    | 16           | LUT2_1 & DFF1   | OUT2:<br>IN0 of LUT2_1 or Clock Input of DFF1 |
|                      | 17           |                 |   |
|                      | 18           |                 |   |
|                      | 19           |                 |   |
|                      | 20           |                 |   |
|                      | 21           |                 |   |
|                      | 22           |                 |   |
|                      | 23           |                 |   |
|                      |              |                 | OUT3:<br>IN1 of LUT2_1 or Data Input of DFF1  |

# SLG46855-A

## Auto AEC-Q100 Qualified GreenPAK Programmable Mixed-Signal Matrix

**Table 57: Register Map (Continued)**

| Address |              | Signal Function | Register Bit Definition                        |
|---------|--------------|-----------------|--|
| Byte    | Register Bit |                 |  |
| 3       | 24           | LUT2_2 & DFF2   | OUT4:<br>IN0 of LUT2_2 or Clock Input of DFF2  |
|         | 25           |                 |  |
|         | 26           |                 |  |
|         | 27           |                 |  |
|         | 28           |                 |  |
|         | 29           |                 |  |
|         | 30           |                 |  |
| 4       | 31           | LUT2_3 & PGen   | OUT5:<br>IN1 of LUT2_2 or Data Input of DFF2   |
|         | 32           |                 |  |
|         | 33           |                 |  |
|         | 34           |                 |  |
|         | 35           |                 |  |
|         | 36           |                 |  |
|         | 37           |                 |  |
| 5       | 38           | LUT2_3 & PGen   | OUT6:<br>IN0 of LUT2_3 or Clock Input of PGen  |
|         | 39           |                 |  |
|         | 40           |                 |  |
|         | 41           |                 |  |
|         | 42           |                 |  |
|         | 43           |                 |  |
|         | 44           |                 |  |
| 6       | 45           | LUT3_0 & DFF3   | OUT7:<br>IN1 of LUT2_3 or nRST of PGen         |
|         | 46           |                 |  |
|         | 47           |                 |  |
|         | 48           |                 |  |
|         | 49           |                 |  |
|         | 50           |                 |  |
|         | 51           |                 |  |
| 7       | 52           | LUT3_0 & DFF3   | OUT8:<br>IN0 of LUT3_0 or CLK Input of DFF3    |
|         | 53           |                 |  |
|         | 54           |                 |  |
|         | 55           |                 |  |
|         | 56           |                 |  |
|         | 57           |                 |  |
|         | 58           |                 |  |
| 8       | 59           | LUT3_1 & DFF4   | OUT9:<br>IN1 of LUT3_0 or Data of DFF3         |
|         | 60           |                 |  |
|         | 61           |                 |  |
|         | 62           |                 |  |
|         | 63           |                 |  |
|         | 64           |                 |  |
|         | 65           |                 |  |
| 8       | 66           | LUT3_1 & DFF4   | OUT10:<br>IN2 of LUT3_0 or nRST (nSET) of DFF3 |
|         | 67           |                 |  |
|         | 68           |                 |  |
|         | 69           |                 |  |
|         | 70           |                 |  |
|         | 71           |                 |  |
| 8       | 66           | LUT3_1 & DFF4   | OUT11:<br>IN0 of LUT3_1 or CLK Input of DFF4   |
|         | 67           |                 |  |
|         | 68           |                 |  |
|         | 69           |                 |  |
|         | 70           |                 |  |
|         | 71           |                 |  |



# SLG46855-A

## Auto AEC-Q100 Qualified GreenPAK Programmable Mixed-Signal Matrix

**Table 57: Register Map (Continued)**

| Address |              | Signal Function | Register Bit Definition                        |
|---------|--------------|-----------------|--|
| Byte    | Register Bit |                 |  |
| 9       | 72           | LUT3_1 & DFF4   | OUT12:<br>IN1 of LUT3_1 or Data of DFF4        |
|         | 73           |                 |  |
|         | 74           |                 |  |
|         | 75           |                 |  |
|         | 76           |                 |  |
|         | 77           |                 |  |
|         | 78           |                 |  |
|         | 79           |                 |  |
| A       | 80           | LUT3_2 & DFF5   | OUT13:<br>IN2 of LUT3_1 or nRST (nSET) of DFF4 |
|         | 81           |                 |  |
|         | 82           |                 |  |
|         | 83           |                 |  |
|         | 84           |                 |  |
|         | 85           |                 |  |
|         | 86           |                 |  |
|         | 87           |                 |  |
| B       | 88           | LUT3_2 & DFF5   | OUT14:<br>IN0 of LUT3_2 or CLK Input of DFF5   |
|         | 89           |                 |  |
|         | 90           |                 |  |
|         | 91           |                 |  |
|         | 92           |                 |  |
|         | 93           |                 |  |
|         | 94           |                 |  |
|         | 95           |                 |  |
| C       | 96           | LUT3_3 & DFF6   | OUT15:<br>IN1 of LUT3_2 or Data of DFF5        |
|         | 97           |                 |  |
|         | 98           |                 |  |
|         | 99           |                 |  |
|         | 100          |                 |  |
|         | 101          |                 |  |
|         | 102          |                 |  |
|         | 103          |                 |  |
| D       | 104          | LUT3_3 & DFF6   | OUT16:<br>IN2 of LUT3_2 or nRST (nSET) of DFF5 |
|         | 105          |                 |  |
|         | 106          |                 |  |
|         | 107          |                 |  |
|         | 108          |                 |  |
|         | 109          |                 |  |
|         | 110          |                 |  |
|         | 111          |                 |  |
| E       | 112          | LUT3_3 & DFF6   | OUT17:<br>IN0 of LUT3_3 or CLK Input of DFF6   |
|         | 113          |                 |  |
|         | 114          |                 |  |
|         | 115          |                 |  |
|         | 116          |                 |  |
|         | 117          |                 |  |
|         | 118          |                 |  |
|         | 119          |                 |  |
|         | 112          | LUT3_3 & DFF6   | OUT18:<br>IN1 of LUT3_3 or Data of DFF6        |
|         | 113          |                 |  |
|         | 114          |                 |  |
|         | 115          |                 |  |
|         | 116          |                 |  |
|         | 117          |                 |  |
|         | 118          |                 |  |
|         | 119          |                 |  |
|         | 112          | LUT3_3 & DFF6   | OUT19:<br>IN2 of LUT3_3 or nRST (nSET) of DFF6 |
|         | 113          |                 |  |
|         | 114          |                 |  |
|         | 115          |                 |  |
|         | 116          |                 |  |
|         | 117          |                 |  |
|         | 118          |                 |  |
|         | 119          |                 |  |

**Auto AEC-Q100 Qualified GreenPAK Programmable Mixed-Signal Matrix**
**Table 57: Register Map (Continued)**

| Address |              | Signal Function | Register Bit Definition                        |
|---------|--------------|-----------------|--|
| Byte    | Register Bit |                 |  |
| F       | 120          | LUT3_4 & DFF7   | OUT20:<br>IN0 of LUT3_4 or CLK Input of DFF7   |
|         | 121          |                 |  |
|         | 122          |                 |  |
|         | 123          |                 |  |
|         | 124          |                 |  |
|         | 125          |                 |  |
|         | 126          |                 |  |
| 10      | 127          | LUT3_4 & DFF7   | OUT21:<br>IN1 of LUT3_4 or Data of DFF7        |
|         | 128          |                 |  |
|         | 129          |                 |  |
|         | 130          |                 |  |
|         | 131          |                 |  |
|         | 132          |                 |  |
|         | 133          |                 |  |
| 11      | 134          | LUT3_5 & DFF8   | OUT22:<br>IN2 of LUT3_4 or nRST (nSET) of DFF7 |
|         | 135          |                 |  |
|         | 136          |                 |  |
|         | 137          |                 |  |
|         | 138          |                 |  |
|         | 139          |                 |  |
|         | 140          |                 |  |
| 12      | 141          | LUT3_5 & DFF8   | OUT23:<br>IN0 of LUT3_5 or CLK Input of DFF8   |
|         | 142          |                 |  |
|         | 143          |                 |  |
|         | 144          |                 |  |
|         | 145          |                 |  |
|         | 146          |                 |  |
|         | 147          |                 |  |
| 13      | 148          | LUT3_5 & DFF8   | OUT24:<br>IN1 of LUT3_5 or Data of DFF8        |
|         | 149          |                 |  |
|         | 150          |                 |  |
|         | 151          |                 |  |
|         | 152          |                 |  |
|         | 153          |                 |  |
|         | 154          |                 |  |
| 14      | 155          | LUT3_6 & DFF9   | OUT25:<br>IN2 of LUT3_5 or nRST (nSET) of DFF8 |
|         | 156          |                 |  |
|         | 157          |                 |  |
|         | 158          |                 |  |
|         | 159          |                 |  |
|         | 160          |                 |  |
|         | 161          |                 |  |
| 14      | 162          | LUT3_6 & DFF9   | OUT26:<br>IN0 of LUT3_6 or CLK Input of DFF9   |
|         | 163          |                 |  |
|         | 164          |                 |  |
|         | 165          |                 |  |
|         | 166          |                 |  |
|         | 167          |                 |  |
|         | 167          |                 |  |
| 14      | 167          | LUT3_6 & DFF9   | OUT27:<br>IN1 of LUT3_6 or Data of DFF9        |

# SLG46855-A

## Auto AEC-Q100 Qualified GreenPAK Programmable Mixed-Signal Matrix

**Table 57: Register Map (Continued)**

| Address |              | Signal Function | Register Bit Definition   |
|---------|--------------|-----------------|---|
| Byte    | Register Bit |                 |   |
| 15      | 168          | LUT3_6 & DFF9   | OUT28:<br>IN2 of LUT3_6 or nRST (nSET) of DFF9  |
|         | 169          |                 |   |
|         | 170          |                 |   |
|         | 171          |                 |   |
|         | 172          |                 |   |
|         | 173          |                 |   |
|         | 174          |                 |   |
| 16      | 176          | LUT3_7 & DFF10  | OUT29:<br>IN0 of LUT3_7 or CLK Input of DFF10   |
|         | 177          |                 |   |
|         | 178          |                 |   |
|         | 179          |                 | OUT30:<br>IN1 of LUT3_7 or Data of DFF10  |
|         | 180          |                 |   |
|         | 181          |                 |   |
|         | 182          |                 |   |
| 17      | 183          | LUT3_8 & DFF11  | OUT31:<br>IN2 of LUT3_7 or nRST (nSET) of DFF10   |
|         | 184          |                 |   |
|         | 185          |                 |   |
|         | 186          |                 |   |
|         | 187          |                 |   |
|         | 188          |                 |   |
|         | 189          |                 |   |
| 18      | 190          | LUT3_8 & DFF11  | OUT32:<br>IN0 of LUT3_8 or CLK Input of DFF11   |
|         | 191          |                 |   |
|         | 192          |                 |   |
|         | 193          |                 |   |
|         | 194          |                 |   |
|         | 195          |                 |   |
|         | 196          |                 |   |
| 19      | 197          | LUT3_8 & DFF11  | OUT33:<br>IN1 of LUT3_8 or Data of DFF11  |
|         | 198          |                 |   |
|         | 199          |                 |   |
|         | 200          |                 | OUT34:<br>IN2 of LUT3_8 or nRST (nSET) of DFF11   |
|         | 201          |                 |   |
|         | 202          |                 |   |
|         | 203          |                 |   |
| 1A      | 204          | Multi_function4 | OUT35:<br>IN0 of LUT3_12 or CLK Input of DFF16<br>Delay4 Input (or Counter4 nRST Input) |
|         | 205          |                 |   |
|         | 206          |                 |   |
|         | 207          |                 |   |
|         | 208          |                 |   |
|         | 209          |                 |   |
|         | 210          |                 |   |
| 1A      | 211          | Multi_function4 | OUT35:<br>IN0 of LUT3_12 or CLK Input of DFF16<br>Delay4 Input (or Counter4 nRST Input) |
|         | 212          |                 |   |
|         | 213          |                 |   |
|         | 214          |                 |   |
|         | 215          |                 |   |

# SLG46855-A

## Auto AEC-Q100 Qualified GreenPAK Programmable Mixed-Signal Matrix

**Table 57: Register Map (Continued)**

| Address |              | Signal Function | Register Bit Definition  |
|---------|--------------|-----------------|--|
| Byte    | Register Bit |                 |  |
| 1B      | 216          | Multi_function4 | OUT36:<br>IN1 of LUT3_12 or nRST (nSET) of DFF16<br>Delay4 Input $\bar{}$ (or Counter4 nRST Input) |
|         | 217          |                 |  |
|         | 218          |                 |  |
|         | 219          |                 |  |
|         | 220          |                 |  |
|         | 221          |                 |  |
|         | 222          |                 |  |
| 1C      | 223          | Multi_function5 | OUT37:<br>IN2 of LUT3_12 or Data of DFF16<br>Delay4 Input $\bar{}$ (or Counter4 nRST Input)        |
|         | 224          |                 |  |
|         | 225          |                 |  |
|         | 226          |                 |  |
|         | 227          |                 |  |
|         | 228          |                 |  |
|         | 229          |                 |  |
| 1D      | 230          | Multi_function6 | OUT38:<br>IN0 of LUT3_13 or CLK Input of DFF17<br>Delay5 Input $\bar{}$ (or Counter5 nRST Input)   |
|         | 231          |                 |  |
|         | 232          |                 |  |
|         | 233          |                 |  |
|         | 234          |                 |  |
|         | 235          |                 |  |
|         | 236          |                 |  |
| 1E      | 237          | Multi_function6 | OUT39:<br>IN1 of LUT3_13 or nRST (nSET) of DFF17<br>Delay5 Input $\bar{}$ (or Counter5 nRST Input) |
|         | 238          |                 |  |
|         | 239          |                 |  |
|         | 240          |                 |  |
|         | 241          |                 |  |
|         | 242          |                 |  |
|         | 243          |                 |  |
| 1F      | 244          | Multi_function6 | OUT40:<br>IN2 of LUT3_13 or Data of DFF17<br>Delay5 Input $\bar{}$ (or Counter5 nRST Input)        |
|         | 245          |                 |  |
|         | 246          |                 |  |
|         | 247          |                 |  |
|         | 248          |                 |  |
|         | 249          |                 |  |
|         | 250          |                 |  |
| 20      | 251          | Multi_function6 | OUT41:<br>IN0 of LUT3_14 or CLK Input of DFF18<br>Delay6 Input $\bar{}$ (or Counter6 nRST Input)   |
|         | 252          |                 |  |
|         | 253          |                 |  |
|         | 254          |                 |  |
|         | 255          |                 |  |
|         | 256          |                 |  |
|         | 257          |                 |  |
| 20      | 258          | Multi_function6 | OUT42:<br>IN1 of LUT3_14 or nRST (nSET) of DFF18<br>Delay6 Input $\bar{}$ (or Counter6 nRST Input) |
|         | 259          |                 |  |
|         | 260          |                 |  |
|         | 261          |                 |  |
|         | 262          |                 |  |
|         | 263          |                 |  |
|         | 263          |                 |  |
| 20      | 260          | Multi_function6 | OUT43:<br>IN2 of LUT3_14 or Data of DFF18<br>Delay6 Input $\bar{}$ (or Counter6 nRST Input)        |
|         | 261          |                 |  |
|         | 262          |                 |  |
|         | 263          |                 |  |
|         | 263          |                 |  |
|         | 263          |                 |  |
|         | 263          |                 |  |

# SLG46855-A

## Auto AEC-Q100 Qualified GreenPAK Programmable Mixed-Signal Matrix

**Table 57: Register Map (Continued)**

| Address |              | Signal Function                 | Register Bit Definition  |
|---------|--------------|---------------------------------|--|
| Byte    | Register Bit |                                 |  |
| 21      | 264          | Multi_function7                 | OUT44:<br>IN0 of LUT3_15 or CLK Input of DFF19<br>Delay7 Input $\bar{}$ (or Counter7 nRST Input)   |
|         | 265          |                                 |  |
|         | 266          |                                 |  |
|         | 267          |                                 |  |
|         | 268          |                                 |  |
|         | 269          |                                 |  |
|         | 270          |                                 |  |
| 22      | 271          | Multi_function7                 | OUT45:<br>IN1 of LUT3_15 or nRST (nSET) of DFF19<br>Delay7 Input $\bar{}$ (or Counter7 nRST Input) |
|         | 272          |                                 |  |
|         | 273          |                                 |  |
|         | 274          |                                 |  |
|         | 275          |                                 |  |
|         | 276          |                                 |  |
|         | 277          |                                 |  |
| 23      | 278          | LUT3_16 & Pipe Delay (RIPP CNT) | OUT46:<br>IN2 of LUT3_15 or Data of DFF19<br>Delay7 Input $\bar{}$ (or Counter7 nRST Input)        |
|         | 279          |                                 |  |
|         | 280          |                                 |  |
|         | 281          |                                 |  |
|         | 282          |                                 |  |
|         | 283          |                                 |  |
|         | 284          |                                 |  |
| 24      | 285          | LUT3_16 & Pipe Delay (RIPP CNT) | OUT47:<br>IN0 of LUT3_16 or Input of Pipe Delay or UP signal of RIPP CNT                           |
|         | 286          |                                 |  |
|         | 287          |                                 |  |
|         | 288          |                                 |  |
|         | 289          |                                 |  |
|         | 290          |                                 |  |
|         | 291          |                                 |  |
| 25      | 292          | LUT3_16 & Pipe Delay (RIPP CNT) | OUT48:<br>IN1 of LUT3_16 or nRST of Pipe Delay or nSET of RIPP CNT                                 |
|         | 293          |                                 |  |
|         | 294          |                                 |  |
|         | 295          |                                 |  |
|         | 296          |                                 |  |
|         | 297          |                                 |  |
|         | 298          |                                 |  |
| 26      | 299          | LUT4_DFF12                      | OUT49:<br>IN2 of LUT3_16 or Clock of Pipe<br>Delay_RIPP CNT  |
|         | 300          |                                 |  |
|         | 301          |                                 |  |
|         | 302          |                                 |  |
|         | 303          |                                 |  |
|         | 304          |                                 |  |
|         | 305          |                                 |  |
| 26      | 306          | LUT4_DFF12                      | OUT50:<br>IN0 of LUT4_0 or CLK Input of DFF12  |
|         | 307          |                                 |  |
|         | 308          |                                 |  |
|         | 309          |                                 |  |
|         | 310          |                                 |  |
|         | 311          |                                 |  |
|         | 311          |                                 |  |
| 26      | 311          | LUT4_DFF12                      | OUT51:<br>IN1 of LUT4_0 or Data of DFF12   |

# SLG46855-A

## Auto AEC-Q100 Qualified GreenPAK Programmable Mixed-Signal Matrix

**Table 57: Register Map (Continued)**

| Address |              | Signal Function    | Register Bit Definition                         |
|---------|--------------|--------------------|---|
| Byte    | Register Bit |                    |   |
| 27      | 312          | LUT4_DFF12         | OUT52:<br>IN2 of LUT4_0 or nRST (nSET) of DFF12 |
|         | 313          |                    |   |
|         | 314          |                    |   |
|         | 315          |                    |   |
|         | 316          |                    |   |
|         | 317          |                    |   |
|         | 318          |                    |   |
| 28      | 319          | Programmable delay | OUT54: Programmable delay/edge detect input     |
|         | 320          |                    |   |
|         | 321          |                    |   |
|         | 322          |                    |   |
|         | 323          |                    |   |
|         | 324          |                    |   |
|         | 325          |                    |   |
| 29      | 326          | Filter/Edge Detect | OUT55: Filter/Edge detect input                 |
|         | 327          |                    |   |
|         | 328          |                    |   |
|         | 329          |                    |   |
|         | 330          |                    |   |
|         | 331          |                    |   |
|         | 332          |                    |   |
| 2A      | 333          | GPIO0              | OUT56: GPIO0 DOUT                               |
|         | 334          |                    |   |
|         | 335          |                    |   |
|         | 336          |                    |   |
|         | 337          |                    |   |
|         | 338          |                    |   |
|         | 339          |                    |   |
| 2B      | 340          | GPIO1              | OUT57: GPIO1 DOUT                               |
|         | 341          |                    |   |
|         | 342          |                    |   |
|         | 343          |                    |   |
|         | 344          |                    |   |
|         | 345          |                    |   |
|         | 346          |                    |   |
| 2C      | 347          | GPIO2              | OUT58: GPIO2 DOUT                               |
|         | 348          |                    |   |
|         | 349          |                    |   |
|         | 350          |                    |   |
|         | 351          |                    |   |
|         | 352          |                    |   |
|         | 353          |                    |   |
| 2C      | 354          | GPIO2              | OUT59: GPIO2 DOUT OE                            |
|         | 355          |                    |   |
|         | 356          |                    |   |
|         | 357          |                    |   |
|         | 358          |                    |   |
|         | 359          |                    |   |

# SLG46855-A

## Auto AEC-Q100 Qualified GreenPAK Programmable Mixed-Signal Matrix

**Table 57: Register Map (Continued)**

| Address |              | Signal Function                          | Register Bit Definition                         |
|---------|--------------|--|---|
| Byte    | Register Bit |  |   |
| 2D      | 360          | GPIO3 DOUT and Input of Power Switch ON0 | OUT60: GPIO3 DOUT and Input of Power Switch ON0 |
|         | 361          |  |   |
|         | 362          |  |   |
|         | 363          |  |   |
|         | 364          |  |   |
|         | 365          |  |   |
|         | 366          |  |   |
| 2E      | 367          | GPO0 and Input of Power Switch ON1       | OUT61: GPIO3 DOUT OE                            |
|         | 368          |  |   |
|         | 369          |  |   |
|         | 370          |  |   |
|         | 371          |  |   |
|         | 372          |  |   |
|         | 373          |  |   |
| 2F      | 374          | GPIO4                                    | OUT62: GPO0 DOUT and Input of Power Switch ON1  |
|         | 375          |  |   |
|         | 376          |  |   |
|         | 377          |  |   |
|         | 378          |  |   |
|         | 379          |  |   |
|         | 380          |  |   |
| 30      | 381          | GPIO4                                    | OUT63: GPIO4 DOUT                               |
|         | 382          |  |   |
|         | 383          |  |   |
|         | 384          |  |   |
|         | 385          |  |   |
|         | 386          |  |   |
|         | 387          |  |   |
| 31      | 388          | GPIO5                                    | OUT64: GPIO4 DOUT OE                            |
|         | 389          |  |   |
|         | 390          |  |   |
|         | 391          |  |   |
|         | 392          |  |   |
|         | 393          |  |   |
|         | 394          |  |   |
| 32      | 395          | GPIO6                                    | OUT65: GPIO5 DOUT                               |
|         | 396          |  |   |
|         | 397          |  |   |
|         | 398          |  |   |
|         | 399          |  |   |
|         | 400          |  |   |
|         | 401          |  |   |
| 32      | 402          | GPIO6                                    | OUT66: GPIO5 DOUT OE                            |
|         | 403          |  |   |
|         | 404          |  |   |
|         | 405          |  |   |
|         | 406          |  |   |
|         | 407          |  |   |
| 32      | 402          | GPIO6                                    | OUT67: GPIO6 DOUT                               |
|         | 403          |  |   |
|         | 404          |  |   |
|         | 405          |  |   |
|         | 406          |  |   |
|         | 407          |  |   |

# SLG46855-A

## Auto AEC-Q100 Qualified GreenPAK Programmable Mixed-Signal Matrix

**Table 57: Register Map (Continued)**

| Address |              | Signal Function | Register Bit Definition                       |
|---------|--------------|-----------------|---|
| Byte    | Register Bit |                 |   |
| 33      | 408          | GPIO6           | OUT68: GPIO6 DOUT OE                          |
|         | 409          |                 |   |
|         | 410          |                 |   |
|         | 411          |                 |   |
|         | 412          |                 |   |
|         | 413          |                 |   |
|         | 414          |                 |   |
| 34      | 415          | GPIO7           | OUT69: GPIO7 DOUT<br><br>OUT70: GPIO7 DOUT OE |
|         | 416          |                 |   |
|         | 417          |                 |   |
|         | 418          |                 |   |
|         | 419          |                 |   |
|         | 420          |                 |   |
|         | 421          |                 |   |
| 35      | 422          | GPIO8           | OUT71: GPIO8 DOUT<br><br>OUT72: GPIO8 DOUT OE |
|         | 423          |                 |   |
|         | 424          |                 |   |
|         | 425          |                 |   |
|         | 426          |                 |   |
|         | 427          |                 |   |
|         | 428          |                 |   |
| 36      | 429          | GPIO9           | OUT73: GPIO9 DOUT<br><br>OUT74: GPIO9 DOUT OE |
|         | 430          |                 |   |
|         | 431          |                 |   |
|         | 432          |                 |   |
|         | 433          |                 |   |
|         | 434          |                 |   |
|         | 435          |                 |   |
| 37      | 436          | ACMP0H          | OUT75:<br>PWR UP of ACMP0H                    |
|         | 437          |                 |   |
|         | 438          |                 |   |
|         | 439          |                 |   |
|         | 440          |                 |   |
|         | 441          |                 |   |
|         | 442          |                 |   |
| 38      | 443          | ACMP0H          | OUT75:<br>PWR UP of ACMP0H                    |
|         | 444          |                 |   |
|         | 445          |                 |   |
|         | 446          |                 |   |
|         | 447          |                 |   |
|         | 448          |                 |   |
|         | 449          |                 |   |
| 38      | 450          | ACMP0H          | OUT75:<br>PWR UP of ACMP0H                    |
|         | 451          |                 |   |
|         | 452          |                 |   |
|         | 453          |                 |   |
|         | 454          |                 |   |
|         | 455          |                 |   |



# SLG46855-A

## Auto AEC-Q100 Qualified GreenPAK Programmable Mixed-Signal Matrix

**Table 57: Register Map (Continued)**

| Address |              | Signal Function | Register Bit Definition  |             |  |
|---------|--------------|-----------------|--|-------------|--|
| Byte    | Register Bit |                 |  |             |  |
| 39      | 456          | ACMP1H          | OUT76:<br>PWR UP of ACMP1H   |             |  |
|         | 457          |                 |  |             |  |
|         | 458          |                 |  |             |  |
|         | 459          |                 |  |             |  |
|         | 460          |                 |  |             |  |
|         | 461          |                 |  |             |  |
|         | 462          |                 |  |             |  |
| 3A      | 464          | ACMP2L          | OUT77:<br>PWR UP of ACMP2L   |             |  |
|         | 465          |                 |  |             |  |
|         | 466          |                 |  |             |  |
|         | 467          |                 |  |             |  |
|         | 468          |                 |  |             |  |
|         | 469          |                 |  |             |  |
|         | 470          |                 |  |             |  |
| 3B      | 471          | ACMP3L          | OUT78:<br>PWR UP of ACMP3L   |             |  |
|         | 472          |                 |  |             |  |
|         | 473          |                 |  |             |  |
|         | 474          |                 |  |             |  |
|         | 475          |                 |  |             |  |
|         | 476          |                 |  | Temp Sensor | OUT79:<br>Temp sensor, Vref Out_0, Vref Out_1 Power Up |
|         | 477          |                 |  |             |  |
| 478     |              |                 |  |             |  |
| 3C      | 479          | OSC0            | OUT80: OSC0 ENABLE   |             |  |
|         | 480          |                 |  |             |  |
|         | 481          |                 |  |             |  |
|         | 482          |                 |  |             |  |
|         | 483          |                 |  |             |  |
|         | 484          |                 |  |             |  |
|         | 485          |                 |  |             |  |
| 3D      | 486          | OSC1            | OUT81: OSC1 ENABLE   |             |  |
|         | 487          |                 |  |             |  |
|         | 488          |                 |  |             |  |
|         | 489          |                 |  |             |  |
|         | 490          |                 |  |             |  |
|         | 491          |                 |  |             |  |
|         | 492          |                 |  |             |  |
| 3E      | 493          | OSC2            | OUT82: OSC2 ENABLE   |             |  |
|         | 494          |                 |  |             |  |
|         | 495          |                 |  |             |  |
|         | 496          |                 |  |             |  |
|         | 497          |                 |  |             |  |
|         | 498          |                 |  |             |  |
|         | 499          |                 |  |             |  |
| 3E      | 500          | Multi_function0 | OUT83:<br>IN0 of LUT4_1 or CLK Input of DFF20<br>Delay0 Input (or Counter0 nRST Input) |             |  |
|         | 501          |                 |  |             |  |
|         | 502          |                 |  |             |  |
|         | 503          |                 |  |             |  |

# SLG46855-A

## Auto AEC-Q100 Qualified GreenPAK Programmable Mixed-Signal Matrix

**Table 57: Register Map (Continued)**

| Address |              | Signal Function   | Register Bit Definition   |   |
|---------|--------------|---|---|---|
| Byte    | Register Bit |   |   |   |
| 3F      | 504          | Multi_function0   | OUT84:<br>IN1 of LUT4_1 or nRST of DFF20<br>Delay0 Input (or Counter0 nRST Input)<br>Delay/Counter0 External CLK source                       |   |
|         | 505          |   |   |   |
|         | 506          |   |   |   |
|         | 507          |   |   |   |
|         | 508          |   |   |   |
|         | 509          |   |   |   |
|         | 510          |   |   |   |
| 40      | 511          |   | OUT85:<br>IN2 of LUT4_1 or nSET of DFF20<br>Delay0 Input (or Counter0 nRST Input)<br>Delay/Counter0 External CLK source<br>KEEP Input of FSM0 |   |
|         | 512          |   |   |   |
|         | 513          |   |   |   |
|         | 514          |   |   |   |
|         | 515          |   |   |   |
|         | 516          |   |   |   |
|         | 517          |   |   |   |
| 41      | 518          | OUT86:<br>IN3 of LUT4_1 or Data of DFF20<br>Delay0 Input (or Counter0 nRST Input)<br>UP Input of FSM0 |   |   |
|         | 519          |   |   |   |
|         | 520          |   |   |   |
|         | 521          |   |   |   |
|         | 522          | OUT87:<br>IN0 of LUT3_9 or CLK Input of DFF13<br>Delay1 Input (or Counter1 nRST Input)                |   |   |
|         | 523          |   |   |   |
|         | 524          |   |   |   |
| 525     |              |   |   |   |
| 526     |              |   |   |   |
| 527     |              |   |   |   |
| 42      | 528          | Multi_function1   | OUT88:<br>IN1 of LUT3_9 or nRST (nSET) of DFF13<br>Delay1 Input (or Counter1 nRST Input)  |   |
|         | 529          |   |   |   |
|         | 530          |   |   |   |
|         | 531          |   |   |   |
|         | 532          |   |   |   |
|         | 533          |   |   |   |
|         | 534          |   |   |   |
| 43      | 535          | Multi_function2   | OUT89:<br>IN2 of LUT3_9 or Data of DFF13<br>Delay1 Input (or Counter1 nRST Input)   |   |
|         | 536          |   |   |   |
|         | 537          |   |   |   |
|         | 538          |   |   |   |
|         | 539          |   |   |   |
|         | 540          |   |   | OUT90:<br>IN0 of LUT3_10 or CLK Input of DFF14<br>Delay2 Input (or Counter2 nRST Input) |
|         | 541          |   |   |   |
| 542     |              |   |   |   |
| 543     |              |   |   |   |
| 544     |              |   |   |   |
| 545     |              |   |   |   |
| 44      | 546          | Multi_function2   | OUT91:<br>IN1 of LUT3_10 or nRST (nSET) of DFF14<br>Delay2 Input (or Counter2 nRST Input)   |   |
|         | 547          |   |   |   |
|         | 548          |   |   |   |
|         | 549          |   |   |   |
|         | 550          |   |   |   |
|         | 551          |   |   |   |

**Auto AEC-Q100 Qualified GreenPAK Programmable Mixed-Signal Matrix**
**Table 57: Register Map (Continued)**

| Address |              | Signal Function | Register Bit Definition  |                |                    |
|---------|--------------|-----------------|--|----------------|--------------------|
| Byte    | Register Bit |                 |  |                |                    |
| 45      | 552          | Multi_function2 | OUT92:<br>IN2 of LUT3_10 or Data of DFF14<br>Delay2 Input $\bar{}$ (or Counter2 nRST Input)        |                |                    |
|         | 553          |                 |  |                |                    |
|         | 554          |                 |  |                |                    |
|         | 555          |                 |  |                |                    |
|         | 556          |                 |  |                |                    |
|         | 557          |                 |  |                |                    |
|         | 558          |                 |  |                |                    |
| 46      | 559          | Multi_function3 | OUT93:<br>IN0 of LUT3_11 or CLK Input of DFF15<br>Delay3 Input $\bar{}$ (or Counter3 nRST Input)   |                |                    |
|         | 560          |                 |  |                |                    |
|         | 561          |                 |  |                |                    |
|         | 562          |                 |  |                |                    |
|         | 563          |                 |  |                |                    |
|         | 564          |                 |  |                |                    |
|         | 565          |                 |  |                |                    |
| 47      | 566          | Multi_function3 | OUT94:<br>IN1 of LUT3_11 or nRST (nSET) of DFF15<br>Delay3 Input $\bar{}$ (or Counter3 nRST Input) |                |                    |
|         | 567          |                 |  |                |                    |
|         | 568          |                 |  |                |                    |
|         | 569          |                 |  |                |                    |
|         | 570          |                 |  |                |                    |
|         | 571          |                 |  |                |                    |
|         | 572          |                 |  |                |                    |
| 48      | 573          | Multi_function3 | OUT95:<br>IN2 of LUT3_11 or Data of DFF15<br>Delay3 Input $\bar{}$ (or Counter3 nRST Input)        |                |                    |
|         | 574          |                 |  |                |                    |
|         | 575          |                 |  |                |                    |
|         | 576          |                 |  | Matrix Input 0 | GND                |
|         | 577          |                 |  | Matrix Input 1 | LUT2_0/DFF0 output |
|         | 578          |                 |  | Matrix Input 2 | LUT2_1/DFF1 output |
|         | 579          |                 |  | Matrix Input 3 | LUT2_2/DFF2 output |
| 49      | 580          | Matrix Input 4  | LUT2_3/PGen output   |                |                    |
|         | 581          | Matrix Input 5  | LUT3_0/DFF3 output   |                |                    |
|         | 582          | Matrix Input 6  | LUT3_1/DFF4 output   |                |                    |
|         | 583          | Matrix Input 7  | LUT3_2/DFF5 output   |                |                    |
|         | 584          | Matrix Input 8  | LUT3_3/DFF6 output   |                |                    |
|         | 585          | Matrix Input 9  | LUT3_4/DFF7 output   |                |                    |
|         | 586          | Matrix Input 10 | LUT3_5/DFF8 output   |                |                    |
| 4A      | 587          | Matrix Input 11 | LUT3_6/DFF9 output   |                |                    |
|         | 588          | Matrix Input 12 | LUT3_7/DFF10 output  |                |                    |
|         | 589          | Matrix Input 13 | LUT3_8/DFF11 output  |                |                    |
|         | 590          | Matrix Input 14 | CNT0 output  |                |                    |
|         | 591          | Matrix Input 15 | MF0_LUT4/DFF_OUT   |                |                    |
|         | 592          | Matrix Input 16 | CNT1 output  |                |                    |
|         | 593          | Matrix Input 17 | MF1_LUT3/DFF_OUT   |                |                    |
| 4A      | 594          | Matrix Input 18 | CNT2 output  |                |                    |
|         | 595          | Matrix Input 19 | MF2_LUT3/DFF_OUT   |                |                    |
|         | 596          | Matrix Input 20 | CNT3 output  |                |                    |
|         | 597          | Matrix Input 21 | MF3_LUT3/DFF_OUT   |                |                    |
|         | 598          | Matrix Input 22 | CNT4 output  |                |                    |
|         | 599          | Matrix Input 23 | MF4_LUT3/DFF_OUT   |                |                    |

**Auto AEC-Q100 Qualified GreenPAK Programmable  
Mixed-Signal Matrix**
**Table 57: Register Map (Continued)**

| Address |              | Signal Function | Register Bit Definition                    |
|---------|--------------|-----------------|--|
| Byte    | Register Bit |                 |  |
| 4B      | 600          | Matrix Input 24 | CNT5 output                                |
|         | 601          | Matrix Input 25 | MF5_LUT3/DFF_OUT                           |
|         | 602          | Matrix Input 26 | CNT6 output                                |
|         | 603          | Matrix Input 27 | MF6_LUT3/DFF_OUT                           |
|         | 604          | Matrix Input 28 | CNT7 output                                |
|         | 605          | Matrix Input 29 | MF7_LUT3/DFF_OUT                           |
|         | 606          | Matrix Input 30 | LUT3_16/Ripple CNT/Pipe Delay_out0         |
|         | 607          | Matrix Input 31 | Ripple CNT/Pipe Delay_out1                 |
| 4C      | 608          | Matrix Input 32 | GPIO0 digital input or I2C_virtual_0 Input |
|         | 609          | Matrix Input 33 | GPIO1 digital input or I2C_virtual_1 Input |
|         | 610          | Matrix Input 34 | I2C_virtual_2 Input                        |
|         | 611          | Matrix Input 35 | I2C_virtual_3 Input                        |
|         | 612          | Matrix Input 36 | I2C_virtual_4 Input                        |
|         | 613          | Matrix Input 37 | I2C_virtual_5 Input                        |
|         | 614          | Matrix Input 38 | I2C_virtual_6 Input                        |
|         | 615          | Matrix Input 39 | I2C_virtual_7 Input                        |
| 4D      | 616          | Matrix Input 40 | Ripple CNT_out2                            |
|         | 617          | Matrix Input 41 | LUT4_0/DFF12 output                        |
|         | 618          | Matrix Input 42 | Programmable Delay Edge Detect Output      |
|         | 619          | Matrix Input 43 | Edge Detect Filter Output                  |
|         | 620          | Matrix Input 44 | GPIO Digital Input                         |
|         | 621          | Matrix Input 45 | GPIO2 Digital Input                        |
|         | 622          | Matrix Input 46 | Power Switch ON0, GPIO3 Digital Input      |
|         | 623          | Matrix Input 47 | GPIO4 Digital Input                        |
| 4E      | 624          | Matrix Input 48 | GPIO5 Digital Input                        |
|         | 625          | Matrix Input 49 | GPIO6 Digital Input                        |
|         | 626          | Matrix Input 50 | GPIO7 Digital Input                        |
|         | 627          | Matrix Input 51 | GPIO8 Digital Input                        |
|         | 628          | Matrix Input 52 | GPIO9 Digital Input                        |
|         | 629          | Matrix Input 53 | OSC0 output 0                              |
|         | 630          | Matrix Input 54 | OSC1 output 0                              |
|         | 631          | Matrix Input 55 | OSC2 output                                |
| 4F      | 632          | Matrix Input 56 | ACMP0H Output (normal speed)               |
|         | 633          | Matrix Input 57 | ACMP1H Output (normal speed)               |
|         | 634          | Matrix Input 58 | ACMP2L Output (low speed)                  |
|         | 635          | Matrix Input 59 | ACMP3L output (low speed)                  |
|         | 636          | Matrix Input 60 | OSC0 output 1                              |
|         | 637          | Matrix Input 61 | OSC1 output 1                              |
|         | 638          | Matrix Input 62 | Matrix nRST                                |
|         | 639          | Matrix Input 63 | V <sub>DD</sub>                            |

**Auto AEC-Q100 Qualified GreenPAK Programmable Mixed-Signal Matrix**
**Table 57: Register Map (Continued)**

| Address |  | Signal Function  | Register Bit Definition   |
|---------|--|--|---|
| Byte    | Register Bit   |  |   |
| 50      | 640  | BG CHOP OFF  | 0: CHOP enable<br>1: chopper off  |
|         | 641  | BG Chopper clock test enable   | 1: enable   |
|         | 642  | Bandgap internal voltage output to IO enable                                 | 1: enable   |
|         | 643  | Bandgap power-down control   | 0: always on<br>1: power-down if no function enable it (ACMP, Vref, TS) |
|         | 644  | ACMP1H external Vref0 source selection                                       | 0: from GPIO2<br>1: from GPO0   |
|         | 645  | ACMP2L external Vref1 source selection                                       | 0: from GPIO2<br>1: from GPO0   |
|         | 646  | ACMP3L external Vref1 source selection                                       | 0: from GPIO2<br>1: from GPO0   |
|         | 647  | ACMP3L wake sleep enable   | 1: enable<br>0: disable   |
| 51      | 648  | VrefO0 register Power-On/Off   | 1: on<br>0: off   |
|         | 649  | VrefO0 power-down selection  | 0: come from register [648]<br>1: come from matrix out92                |
|         | 650  | VrefO1 register Power-On/Off   | 1: on<br>0: off   |
|         | 651  | ACMP0H hysteresis  | 00: 0 mV<br>01: 32 mV<br>10: 64 mV<br>11: 192 mV                        |
|         | 652  |  |   |
|         | 653  | Reserved   |   |
|         | 654  | ACMP0_H input buffer enable  | 1: enable   |
| 655     | Reserved   |  |   |
| 52      | 656  | ACMP0H input tie to V <sub>DD</sub> enable                                   | 1: enable   |
|         | 657  | ACMP1_H positive input come from ACMP0_H's input mux output enable; 1:enable |   |
|         | 658  | Reserved   |   |
|         | 659  | ACMP1H hysteresis  | 00: 0 mV<br>01: 32 mV<br>10: 64 mV<br>11: 192 mV                        |
|         | 660  |  |   |
|         | 661  | ACMP1H input buffer enable   | 1: enable   |
|         | 662  | Reserved   |   |
| 663     | ACMP2L positive input come from ACMP0H's input mux output enable | 1: enable  |   |
| 53      | 664  | ACMP2L positive input come from ACMP1H's input mux output enable             | 1: enable   |
|         | 665  | ACMP2L hysteresis  | 00: 0 mV<br>01: 32 mV<br>10: 64 mV<br>11: 192 mV                        |
|         | 666  |  |   |
|         | 667  | Reserved   |   |
|         | 668  | Reserved   |   |
|         | 669  | ACMP3_L hysteresis   | 00: 0 mV<br>01: 32 mV<br>10: 64 mV<br>11: 192 mV                        |
|         | 670  |  |   |
| 671     | Reserved   |  |   |

**Auto AEC-Q100 Qualified GreenPAK Programmable Mixed-Signal Matrix**
**Table 57: Register Map (Continued)**

| Address |              | Signal Function   | Register Bit Definition   |
|---------|--------------|---|---|
| Byte    | Register Bit |   |   |
| 54      | 672          | Reserved  |   |
|         | 673          | ACMP3_L positive input come from ACMP2L's input mux output enable | 1: enable   |
|         | 674          | Temp sensor register pdb control                                  | 0: Power-down<br>1: Power-On  |
|         | 675          | Temp sensor register pdb select                                   | 0: come from register<br>1: come from Matrix                        |
|         | 676          | Temp sensor range select  | 0: range 1 (0.62V ~ 0.99V (TYP))<br>1: range 2 (0.75V ~ 1.2V (TYP)) |
|         | 677          | Vref0 output OP   | 0: disable<br>1: enable   |
|         | 678          | Vref0 input selection   | 00: None  |
|         | 679          |   | 01: ACMP0H Vref<br>10: ACMP1H Vref<br>11: temp sensor               |
| 55      | 680          | Vref1 output OP   | 0: disable<br>1: enable   |
|         | 681          | Vref1 input selection   | 00: None  |
|         | 682          |   | 01: ACMP2L Vref<br>10: ACMP3L Vref                                  |
|         | 683          | VBG fine tune selection   | 0000: 1.194, 0001:1.195, 0011:1.196, 0100:1.197,                    |
|         | 684          |   | 0101:1.198, 0110:1.199 0111:1.2, 1000:1.201, 1001:1.202,            |
|         | 685          |   | 1010:1.203, 1011:1.204, 1100:1.205, 1101:1.206,                     |
|         | 686          |   | 1110:1.207, 1111:1.208  |
|         |              | 687   | ACMP0H Wake/Sleep enable  |
|         | 688          | ACMP1H Wake/Sleep enable  |   |
| 56      | 689          | ACMP Wake/Sleep time selection                                    | 0: short time<br>1: normal w/s                                      |
|         | 690          | ACMP0H 100 uA current source enable                               |   |
|         | 691          | Reserve for ACMP  |   |
|         | 692          | Reserved  |   |
|         | 693          | ACMP3L input come from Temp sensor output enable                  |   |
|         | 694          | VrefO1 power-down selection                                       | 0: come from register [650]<br>1: come from matrix OUT92            |
|         | 695          | ACMP2L wake sleep enable  | 0: disable<br>1: enable   |
|         | 57           | 696   | ACMP0H Gain divider   |
| 697     |              | 01:0.5x<br>10:0.33x<br>11:0.25x                                   |   |
| 698     |              | ACMP0H Vref0  | ACMP Vref select:<br>000000: 32mV ~                                 |
| 699     |              |   | 111110: 2.016V/step = 32 mV   |
| 700     |              |   | 111111: External Vref   |
| 701     |              |   |   |
| 702     |              |   |   |
| 703     |              |   |   |

**Auto AEC-Q100 Qualified GreenPAK Programmable Mixed-Signal Matrix**
**Table 57: Register Map (Continued)**

| Address     |              | Signal Function                         | Register Bit Definition   |
|-------------|--------------|---|---|
| Byte        | Register Bit |   |   |
| 58          | 704          | ACMP1H Gain divider                     | ACMP gain divider select:<br>00: 1x<br>01:0.5x<br>10:0.33x<br>11:0.25x                        |
|             | 705          |   |   |
|             | 706          | ACMP1H Vref0                            | ACMP Vref select:<br>000000: 32 mV ~ 1<br>11110: 2.016V/step = 32mV<br>111111: External Vref  |
|             | 707          |   |   |
|             | 708          |   |   |
|             | 709          |   |   |
|             | 710          |   |   |
| 711         |              |   |   |
| 59          | 712          | ACMP2L Gain divider                     | ACMP gain divider select:<br>00: 1x<br>01:0.5x<br>10:0.33x<br>11:0.25x                        |
|             | 713          |   |   |
|             | 714          | ACMP2L Vref1                            | ACMP Vref select:<br>000000: 32 mV ~<br>111110: 2.016V/step = 32mV<br>111111: External Vref   |
|             | 715          |   |   |
|             | 716          |   |   |
|             | 717          |   |   |
|             | 718          |   |   |
| 719         |              |   |   |
| 5A          | 720          | ACMP3L Gain divider                     | ACMP gain divider select:<br>00: 1x<br>01:0.5x<br>10:0.33x<br>11:0.25x                        |
|             | 721          |   |   |
|             | 722          | ACMP3L Vref1                            | ACMP Vref select:<br>000000: 32 mV ~<br>111110: 2.016V/step = 32mV<br>111112: External Vref   |
|             | 723          |   |   |
|             | 724          |   |   |
|             | 725          |   |   |
|             | 726          |   |   |
| 727         |              |   |   |
| <b>OSC1</b> |              |   |   |
| 5B          | 728          | OSC1 turn on by register                | when matrix output enable/pd control signal = 0:<br>0: auto on by delay cells<br>1: always on |
|             | 729          | matrix power-down or on select          | 0: matrix down<br>1: matrix on  |
|             | 730          | external clock source enable            | 0: internal OSC1<br>1: external clock from GPIO2  |
|             | 731          | post divider ratio control OSC1         | 00: div 1<br>01: div 2<br>10: div 4<br>11: div 8  |
|             | 732          |   |   |
|             | 733          | matrix divider ratio control OSC1, OUT0 | 000: /1, 001:/2 , 010:/4, 011: /3, 100: /8, 101: /12, 110: /24,<br>111: /64                   |
|             | 734          |   |   |
| 735         |              |   |   |
| 5C          | 736          | matrix out enable OSC1, OUT0            | 0: disable<br>1: enable   |
|             | 737          | Reserved                                |   |
|             | 738          | Reserved                                |   |
|             | 739          | Reserved                                |   |

**Auto AEC-Q100 Qualified GreenPAK Programmable Mixed-Signal Matrix**
**Table 57: Register Map (Continued)**

| Address     |  | Signal Function                         | Register Bit Definition   |
|-------------|--|---|---|
| Byte        | Register Bit   |   |   |
| <b>OSC2</b> |  |   |   |
| 5C          | 740  | OSC2 turn on by register                | when matrix output enable/pd control signal = 0:<br>0: auto on by delay cells<br>1: always on |
|             | 741  | matrix power-down or on select          | 0: matrix down<br>1: matrix on  |
|             | 742  | external clock source enable            | 0: internal OSC2<br>1: external clock from GPIO8  |
|             | 743  | matrix out enable                       | 0: disable<br>1: enable   |
| 5D          | 744  | post divider ratio control OSC2         | 00: div 1<br>01: div 2<br>10: div 4<br>11: div 8  |
|             | 745  |   |   |
|             | 746  | matrix divider ratio control OSC2       | 000: /1, 001:/2 , 010:/4, 011: /3, 100: /8, 101: /12, 110: /24, 111: /64                      |
|             | 747  |   |   |
|             | 748  |   |   |
| 749         | startup delay with 100 ns  | 0: enable<br>1: disable                 |   |
| <b>OSC0</b> |  |   |   |
| 5D          | 750  | OSC0 turn on by register                | when matrix output enable/pd control signal = 0:<br>0: auto on by delay cells<br>1: always on |
|             | 751  | matrix power-down or on select          | 0: matrix down<br>1: matrix on  |
| 5E          | 752  | external clock source enable            | 0: internal OSC0<br>1: external clock from GPIO   |
|             | 753  | matrix out enable OSC0, OUT0            | 0: disable<br>1: enable   |
|             | 754  | post divider ratio control OSC0         | 00: div 1<br>01: div 2<br>10: div 4<br>11: div 8  |
|             | 755  |   |   |
|             | 756  | matrix divider ratio control OSC0, OUT0 | 000: /1, 001:/2 , 010:/4, 011: /3, 100: /8, 101: /12, 110: /24, 111: /64                      |
|             | 757  |   |   |
|             | 758  |   |   |
| 759         | enable OSC0 output gating by wake_sleep signal<br>(note: the wake_sleep clock is separated path, so it is not gated) | 0: no gating<br>1: enable               |   |
| 5F          | 760  | matrix divider ratio control OSC1, OUT1 | 000: /1, 001:/2 , 010:/4, 011: /3, 100: /8, 101: /12, 110: /24, 111: /64                      |
|             | 761  |   |   |
|             | 762  |   |   |
|             | 763  | 2nd output to matrix enable OSC1        | 0: disable<br>1: enable   |
|             | 764  | matrix divider ratio control OSC0, OUT1 | 000: /1, 001:/2 , 010:/4, 011: /3, 100: /8, 101: /12, 110: /24, 111: /64                      |
|             | 765  |   |   |
|             | 766  |   |   |
| 767         | 2nd output to matrix enable OSC0, OUT1   | 0: disable<br>1: enable                 |   |



**Auto AEC-Q100 Qualified GreenPAK Programmable Mixed-Signal Matrix**
**Table 57: Register Map (Continued)**

| Address      |              | Signal Function                   | Register Bit Definition   |
|--------------|--------------|-----------------------------------|---|
| Byte         | Register Bit |                                   |   |
| 60           | 768          | Reserved                          |   |
|              | 769          |                                   |   |
|              | 770          | Reserved                          |   |
|              | 771          | Reserved                          |   |
|              | 772          | Reserved                          |   |
|              | 773          | Reserved                          |   |
|              | 774          | Reserved                          |   |
|              | 775          | Reserved                          |   |
| 61           | 776          | Reserved                          |   |
|              | 777          | Reserved                          |   |
|              | 778          | IO fast Pull-up/down enable       | 0: disable<br>1: enable   |
| <b>GPIO</b>  |              |                                   |   |
| 61           | 779          | input mode configuration          | 00: digital without Schmitt Trigger<br>01: digital with Schmitt Trigger<br>10: low voltage digital in<br>11: analog IO                                    |
|              | 780          |                                   |   |
|              | 781          | Pull-up/down resistance selection | 00: floating<br>01: 10K<br>10: 100K<br>11: 1M   |
|              | 782          |                                   |   |
|              | 783          | Pull-up/down selection            | 0: Pull-down<br>1: Pull-up  |
| <b>GPIO0</b> |              |                                   |   |
| 62           | 784          | input mode configuration          | 00: digital in without Schmitt Trigger<br>01: digital in with Schmitt Trigger<br>(when register [2032] = 1)<br>10: low voltage digital in<br>11: Reserved |
|              | 785          |                                   |   |
|              | 786          | Pull-up/down resistance selection | 00: floating<br>01: 10K<br>10: 100K<br>11: 1M   |
|              | 787          |                                   |   |
|              | 788          | Pull-up/down selection            | 0: Pull-down<br>1: Pull-up  |
|              | 789          | I <sup>2</sup> C mode selection   | 0: I <sup>2</sup> C fast mode+ (3.2x drivability)<br>1: I <sup>2</sup> C standard/fast mode   |
|              | 790          | I/O selection                     | 0: digital input<br>1: digital output (3.2x Open-Drain NMOS)  |
| <b>GPIO1</b> |              |                                   |   |
| 62           | 791          | input mode configuration          | 00: digital without Schmitt Trigger<br>01: digital in with Schmitt Trigger<br>(when register [2032] = 1)<br>10: low voltage digital in<br>11: Reserved    |
| 63           | 792          |                                   |   |
|              | 793          | Pull-up/down resistance selection | 00: floating<br>01: 10K<br>10: 100K<br>11: 1M   |
|              | 794          |                                   |   |
|              | 795          | Pull-up/down selection            | 0: Pull-down<br>1: Pull-up  |
|              | 796          | I/O selection                     | 0: digital input<br>1: digital output (3.2x Open-Drain NMOS)  |
|              | 797          | Reserved                          |   |

**Auto AEC-Q100 Qualified GreenPAK Programmable  
Mixed-Signal Matrix**
**Table 57: Register Map (Continued)**

| Address      |                        | Signal Function                   | Register Bit Definition   |  |
|--------------|------------------------|-----------------------------------|---|--|
| Byte         | Register Bit           |                                   |   |  |
| <b>GPIO2</b> |                        |                                   |   |  |
| 63           | 798                    | input mode configuration          | 00: digital without Schmitt Trigger   |  |
|              | 799                    |                                   | 01: digital with Schmitt Trigger<br>10: low voltage digital in<br>11: analog IO |  |
| 64           | 800                    | output mode configuration         | 00: Push-Pull 1x  |  |
|              | 801                    |                                   | 01: Push-Pull 2x<br>10: 1x Open-Drain<br>11: 2x Open-Drain                      |  |
|              | 802                    | Pull-up/down resistance selection | 00: floating  |  |
|              | 803                    |                                   | 01: 10K<br>10: 100K<br>11: 1M   |  |
| 804          | Pull-up/down selection | 0: Pull-down<br>1: Pull-up        |   |  |
| <b>GPIO3</b> |                        |                                   |   |  |
| 64           | 805                    | input mode configuration          | 00: digital without Schmitt Trigger   |  |
|              | 806                    |                                   | 01: digital with Schmitt Trigger  |  |
|              | 807                    |                                   | 10: low voltage digital in<br>11: analog IO                                     |  |
| 65           | 808                    | output mode configuration         | 00: Push-Pull 1x<br>01: Push-Pull 2x<br>10: 1x Open-Drain<br>11: 2x Open-Drain  |  |
| 65           | 809                    | Pull-up/down resistance selection | 00: floating  |  |
|              | 810                    |                                   | 01: 10K<br>10: 100K<br>11: 1M   |  |
|              | 811                    |                                   | Pull-up/down selection  | 0: Pull-down<br>1: Pull-up                                 |
| <b>GPO0</b>  |                        |                                   |   |  |
| 65           | 812                    | Reserved                          |   |  |
|              | 813                    |                                   |   |  |
|              | 814                    |                                   | output mode configuration   | 00: Push-Pull 1x   |
|              | 815                    |                                   |   | 01: Push-Pull 2x<br>10: 1x Open-Drain<br>11: 2x Open-Drain |
| 66           | 816                    | Pull-up/down resistance selection | 00: floating  |  |
|              | 817                    |                                   | 01: 10K<br>10: 100K<br>11: 1M   |  |
|              | 818                    | Pull-up/down selection            | 0: Pull-down<br>1: Pull-up  |  |
|              | 819                    | output enable                     | 0: output disable (input mode)<br>1: output enable                              |  |
|              | 820                    | 4x drive                          | 0: disable<br>1: enable   |  |
| <b>GPIO4</b> |                        |                                   |   |  |

**Auto AEC-Q100 Qualified GreenPAK Programmable Mixed-Signal Matrix**
**Table 57: Register Map (Continued)**

| Address      |              | Signal Function                   | Register Bit Definition  |   |                         |
|--------------|--------------|-----------------------------------|--|---|-------------------------|
| Byte         | Register Bit |                                   |  |   |                         |
| 66           | 821          | input mode configuration          | 00: digital without Schmitt Trigger  |   |                         |
|              | 822          |                                   | 01: digital with Schmitt Trigger   |   |                         |
|              | 823          |                                   | 10: low voltage digital in<br>11: analog IO                                    |   |                         |
| 67           | 824          | output mode configuration         | 00: Push-Pull 1x<br>01: Push-Pull 2x<br>10: 1x Open-Drain<br>11: 2x Open-Drain |   |                         |
|              | 825          |                                   | Pull-up/down resistance selection  | 00: floating<br>01: 10K<br>10: 100K<br>11: 1M |                         |
|              | 826          | Pull-up/down selection            |  | 0: Pull-down<br>1: Pull-up                    |                         |
|              | 827          |                                   |  | 4x drive                                      | 0: disable<br>1: enable |
|              | 828          |                                   |  |   |                         |
| <b>GPIO5</b> |              |                                   |  |   |                         |
| 67           | 829          | input mode configuration          | 00: digital without Schmitt Trigger  |   |                         |
|              | 830          |                                   | 01: digital with Schmitt Trigger   |   |                         |
|              | 831          |                                   | 10: low voltage digital in<br>11: analog IO                                    |   |                         |
| 68           | 832          | output mode configuration         | 00: Push-Pull 1x<br>01: Push-Pull 2x<br>10: 1x Open-Drain<br>11: 2x Open-Drain |   |                         |
|              | 833          |                                   | Pull-up/down resistance selection  | 00: floating<br>01: 10K<br>10: 100K<br>11: 1M |                         |
|              | 834          | Pull-up/down selection            |  | 0: Pull-down<br>1: Pull-up                    |                         |
|              | 835          |                                   |  |   |                         |
| <b>GPIO6</b> |              |                                   |  |   |                         |
| 68           | 836          | input mode configuration          | 00: digital without Schmitt Trigger  |   |                         |
|              | 837          |                                   | 01: digital with Schmitt Trigger   |   |                         |
|              | 838          |                                   | 10: low voltage digital in<br>11: analog IO                                    |   |                         |
|              | 839          | output mode configuration         | 00: Push-Pull 1x<br>01: Push-Pull 2x<br>10: 1x Open-Drain<br>11: 2x Open-Drain |   |                         |
| 69           | 840          | Pull-up/down resistance selection | 00: floating<br>01: 10K<br>10: 100K<br>11: 1M                                  |   |                         |
|              | 841          |                                   | Pull-up/down selection   | 0: Pull-down<br>1: Pull-up                    |                         |
|              | 842          |                                   |  |   |                         |
| <b>GPIO7</b> |              |                                   |  |   |                         |

**Auto AEC-Q100 Qualified GreenPAK Programmable Mixed-Signal Matrix**
**Table 57: Register Map (Continued)**

| Address      |              | Signal Function                   | Register Bit Definition             |
|--------------|--------------|-----------------------------------|-------------------------------------|
| Byte         | Register Bit |                                   |                                     |
| 69           | 843          | input mode configuration          | 00: digital without Schmitt Trigger |
|              | 844          |                                   | 01: digital with Schmitt Trigger    |
|              | 845          | output mode configuration         | 10: low voltage digital in          |
|              | 846          |                                   | 11: analog IO                       |
|              | 847          |                                   | 00: Push-Pull 1x                    |
| 6A           | 848          | Pull-up/down resistance selection | 01: Push-Pull 2x                    |
|              | 849          | Pull-up/down selection            | 10: 1x Open-Drain                   |
| <b>GPIO8</b> |              |                                   |                                     |
| 6A           | 850          | input mode configuration          | 11: 2x Open-Drain                   |
|              | 851          |                                   | 00: floating                        |
|              | 852          | output mode configuration         | 01: 10K                             |
|              | 853          |                                   | 10: 100K                            |
|              | 854          |                                   | 11: 1M                              |
|              | 855          | Pull-up/down resistance selection | 0: Pull-down                        |
| 6B           | 856          | Pull-up/down selection            | 1: Pull-up                          |
| <b>GPIO9</b> |              |                                   |                                     |
| 6B           | 857          | input mode configuration          | 00: digital without Schmitt Trigger |
|              | 858          |                                   | 01: digital with Schmitt Trigger    |
|              | 859          | output mode configuration         | 10: low voltage digital in          |
|              | 860          |                                   | 11: analog IO                       |
|              | 861          |                                   | 00: Push-Pull 1x                    |
|              | 862          | Pull-up/down resistance selection | 01: Push-Pull 2x                    |
|              | 863          | Pull-up/down selection            | 10: 1x Open-Drain                   |
| 6C           | 864          | Reserved                          | 11: 2x Open-Drain                   |
|              | 865          | Reserved                          | 00: floating                        |
|              | 866          | Reserved                          | 01: 10K                             |
|              | 867          | Reserved                          | 10: 100K                            |
|              | 868          | Reserved                          | 11: 1M                              |
|              | 869          | Reserved                          | 0: Pull-down                        |
|              | 870          | Reserved                          | 1: Pull-up                          |
|              | 871          | Reserved                          |                                     |

**Auto AEC-Q100 Qualified GreenPAK Programmable  
Mixed-Signal Matrix**
**Table 57: Register Map (Continued)**

| Address |              | Signal Function | Register Bit Definition |
|---------|--------------|-----------------|-------------------------|
| Byte    | Register Bit |                 |                         |
| 6D      | 872          | Reserved        |                         |
|         | 873          | Reserved        |                         |
|         | 874          | Reserved        |                         |
|         | 875          | Reserved        |                         |
|         | 876          | Reserved        |                         |
|         | 877          | Reserved        |                         |
|         | 878          | Reserved        |                         |
|         | 879          | Reserved        |                         |
| 6E      | 880          | Reserved        |                         |
|         | 881          | Reserved        |                         |
|         | 882          | Reserved        |                         |
|         | 883          | Reserved        |                         |
|         | 884          | Reserved        |                         |
|         | 885          | Reserved        |                         |
|         | 886          | Reserved        |                         |
|         | 887          | Reserved        |                         |
| 6F      | 888          | Reserved        |                         |
|         | 889          | Reserved        |                         |
|         | 890          | Reserved        |                         |
|         | 891          | Reserved        |                         |
|         | 892          | Reserved        |                         |
|         | 893          | Reserved        |                         |
|         | 894          | Reserved        |                         |
|         | 895          | Reserved        |                         |
| 70      | 896          | Reserved        |                         |
|         | 897          | Reserved        |                         |
|         | 898          | Reserved        |                         |
|         | 899          | Reserved        |                         |
|         | 900          | Reserved        |                         |
|         | 901          | Reserved        |                         |
|         | 902          | Reserved        |                         |
|         | 903          | Reserved        |                         |
| 71      | 904          | Reserved        |                         |
|         | 905          | Reserved        |                         |
|         | 906          | Reserved        |                         |
|         | 907          | Reserved        |                         |
|         | 908          | Reserved        |                         |
|         | 909          | Reserved        |                         |
|         | 910          | Reserved        |                         |
|         | 911          | Reserved        |                         |
| 72      | 912          | Reserved        |                         |
|         | 913          | Reserved        |                         |
|         | 914          | Reserved        |                         |
|         | 915          | Reserved        |                         |
|         | 916          | Reserved        |                         |
|         | 917          | Reserved        |                         |
|         | 918          | Reserved        |                         |
|         | 919          | Reserved        |                         |

# SLG46855-A

## Auto AEC-Q100 Qualified GreenPAK Programmable Mixed-Signal Matrix

**Table 57: Register Map (Continued)**

| Address |              | Signal Function | Register Bit Definition |
|---------|--------------|-----------------|-------------------------|
| Byte    | Register Bit |                 |                         |
| 73      | 920          | Reserved        |                         |
|         | 921          | Reserved        |                         |
|         | 922          | Reserved        |                         |
|         | 923          | Reserved        |                         |
|         | 924          | Reserved        |                         |
|         | 925          | Reserved        |                         |
|         | 926          | Reserved        |                         |
|         | 927          | Reserved        |                         |
| 74      | 928          | Reserved        |                         |
|         | 929          | Reserved        |                         |
|         | 930          | Reserved        |                         |
|         | 931          | Reserved        |                         |
|         | 932          | Reserved        |                         |
|         | 933          | Reserved        |                         |
|         | 934          | Reserved        |                         |
|         | 935          | Reserved        |                         |
| 75      | 936          | Reserved        |                         |
|         | 937          | Reserved        |                         |
|         | 938          | Reserved        |                         |
|         | 939          | Reserved        |                         |
|         | 940          | Reserved        |                         |
|         | 941          | Reserved        |                         |
|         | 942          | Reserved        |                         |
|         | 943          | Reserved        |                         |
| 76      | 944          | Reserved        |                         |
|         | 945          | Reserved        |                         |
|         | 946          | Reserved        |                         |
|         | 947          | Reserved        |                         |
|         | 948          | Reserved        |                         |
|         | 949          | Reserved        |                         |
|         | 950          | Reserved        |                         |
|         | 951          | Reserved        |                         |
| 77      | 952          | Reserved        |                         |
|         | 953          | Reserved        |                         |
|         | 954          | Reserved        |                         |
|         | 955          | Reserved        |                         |
|         | 956          | Reserved        |                         |
|         | 957          | Reserved        |                         |
|         | 958          | Reserved        |                         |
|         | 959          | Reserved        |                         |
| 78      | 960          | Reserved        |                         |
|         | 961          | Reserved        |                         |
|         | 962          | Reserved        |                         |
|         | 963          | Reserved        |                         |
|         | 964          | Reserved        |                         |
|         | 965          | Reserved        |                         |
|         | 966          | Reserved        |                         |
|         | 967          | Reserved        |                         |

# SLG46855-A

## Auto AEC-Q100 Qualified GreenPAK Programmable Mixed-Signal Matrix

**Table 57: Register Map (Continued)**

| Address |              | Signal Function | Register Bit Definition |
|---------|--------------|-----------------|-------------------------|
| Byte    | Register Bit |                 |                         |
| 79      | 968          | Reserved        |                         |
|         | 969          | Reserved        |                         |
|         | 970          | Reserved        |                         |
|         | 971          | Reserved        |                         |
|         | 972          | Reserved        |                         |
|         | 973          | Reserved        |                         |
|         | 974          | Reserved        |                         |
|         | 975          | Reserved        |                         |
| 7A      | 976          | Reserved        |                         |
|         | 977          | Reserved        |                         |
|         | 978          | Reserved        |                         |
|         | 979          | Reserved        |                         |
|         | 980          | Reserved        |                         |
|         | 981          | Reserved        |                         |
|         | 982          | Reserved        |                         |
|         | 983          | Reserved        |                         |
| 7B      | 984          | Reserved        |                         |
|         | 985          | Reserved        |                         |
|         | 986          | Reserved        |                         |
|         | 987          | Reserved        |                         |
|         | 988          | Reserved        |                         |
|         | 989          | Reserved        |                         |
|         | 990          | Reserved        |                         |
|         | 991          | Reserved        |                         |
| 7C      | 992          | Reserved        |                         |
|         | 993          | Reserved        |                         |
|         | 994          | Reserved        |                         |
|         | 995          | Reserved        |                         |
|         | 996          | Reserved        |                         |
|         | 997          | Reserved        |                         |
|         | 998          | Reserved        |                         |
|         | 999          | Reserved        |                         |
| 7D      | 1000         | Reserved        |                         |
|         | 1001         | Reserved        |                         |
|         | 1002         | Reserved        |                         |
|         | 1003         | Reserved        |                         |
|         | 1004         | Reserved        |                         |
|         | 1005         | Reserved        |                         |
|         | 1006         | Reserved        |                         |
|         | 1007         | Reserved        |                         |
| 7E      | 1008         | Reserved        |                         |
|         | 1009         | Reserved        |                         |
|         | 1010         | Reserved        |                         |
|         | 1011         | Reserved        |                         |
|         | 1012         | Reserved        |                         |
|         | 1013         | Reserved        |                         |
|         | 1014         | Reserved        |                         |
|         | 1015         | Reserved        |                         |

**Auto AEC-Q100 Qualified GreenPAK Programmable Mixed-Signal Matrix**
**Table 57: Register Map (Continued)**

| Address       |  | Signal Function          | Register Bit Definition   |
|---------------|--|--------------------------|---|
| Byte          | Register Bit   |                          |   |
| 7F            | 1016   | Reserved                 |   |
|               | 1017   | Reserved                 |   |
|               | 1018   | Reserved                 |   |
|               | 1019   | Reserved                 |   |
|               | 1020   | Reserved                 |   |
|               | 1021   | Reserved                 |   |
|               | 1022   | Reserved                 |   |
|               | 1023   | Reserved                 |   |
| 80            | 1030:1024  | Single 4-bit LUT         | 0000000: Matrix A - In3; Matrix B - In2; Matrix C - In1; Matrix D - In0 (DLY_IN - LOW)  |
|               |  | Single DFF w RST and SET | 0010000: Matrix A - D; Matrix B - nSET; Matrix C - nRST; Matrix D - CLK (DLY_IN - LOW)  |
|               |  | Single CNT/DLY           | 0000001: Matrix A - UP (CNT); Matrix B - KEEP (CNT); Matrix C - EXT_CLK (CNT); Matrix D - DLY_IN (CNT) (DLY_OUT connected to LUT/DFF) |
|               |  | CNT/DLY → LUT            | 0000010: Matrix A - DLY_IN; Matrix B - In2; Matrix C - In1; Matrix D - In0 (DLY_OUT connected to In3)                                 |
|               |  | CNT/DLY → DFF            | 0010010: Matrix A - DLY_IN; Matrix B - nSET; Matrix C - nRST; Matrix D - CLK (DLY_OUT connected to D)                                 |
|               |  | CNT/DLY → LUT            | 0100010: Matrix A - DLY_IN; Matrix B - EXT_CLK (CNT); Matrix C - In1; Matrix D - In0 (DLY_OUT connected to In3; In2 - LOW)            |
|               |  | CNT/DLY → DFF            | 0110010: Matrix A - DLY_IN; Matrix B - EXT_CLK (CNT); Matrix C - nRST; Matrix D - CLK (DLY_OUT connected to D; nSET - HIGH)           |
|               |  | CNT/DLY → LUT            | 1000010: Matrix A - DLY_IN; Matrix B - In2; Matrix C - EXT_CLK (CNT); Matrix D - In0 (DLY_OUT connected to In3; In1 - LOW)            |
|               |  | CNT/DLY → DFF            | 1010010: Matrix A - DLY_IN; Matrix B - nSET; Matrix C - EXT_CLK (CNT); Matrix D - CLK (DLY_OUT connected to D; nRST - HIGH)           |
|               |  | CNT/DLY → LUT            | 0000110: Matrix A - In3; Matrix B - DLY_IN; Matrix C - In1; Matrix D - In0 (DLY_OUT connected to In2)                                 |
|               |  | CNT/DLY → DFF            | 0010110: Matrix A - D; Matrix B - DLY_IN; Matrix C - nRST; Matrix D - CLK (DLY_OUT connected to nSET)                                 |
| CNT/DLY → LUT | 1000110: Matrix A - In3; Matrix B - DLY_IN; Matrix C - EXT_CLK (CNT); Matrix D - In0 (DLY_OUT connected to In2; In1 - LOW) |                          |   |



**Auto AEC-Q100 Qualified GreenPAK Programmable Mixed-Signal Matrix**
**Table 57: Register Map (Continued)**

| Address |              | Signal Function | Register Bit Definition   |
|---------|--------------|-----------------|---|
| Byte    | Register Bit |                 |   |
| 80      | 1030:1024    | CNT/DLY → DFF   | 1010110: Matrix A - D; Matrix B - DLY_IN; Matrix C - EXT_CLK (CNT);<br>Matrix D - CLK<br>(DLY_OUT connected to nSET; nRST - HIGH)   |
|         |              | CNT/DLY → LUT   | 0001010: Matrix A - In3; Matrix B - In2; Matrix C - DLY_IN;<br>Matrix D - In0<br>(DLY_OUT connected to In1)                         |
|         |              | CNT/DLY → DFF   | 0011010: Matrix A - D; Matrix B - nSET; Matrix C - DLY_IN;<br>Matrix D - CLK<br>(DLY_OUT connected to nRST)                         |
|         |              | CNT/DLY → LUT   | 0101010: Matrix A - In3; Matrix B - EXT_CLK (CNT);<br>Matrix C - DLY_IN;<br>Matrix D - In0<br>(DLY_OUT connected to In1; In2 - LOW) |
|         |              | CNT/DLY → DFF   | 0111010: Matrix A - D; Matrix B - EXT_CLK (CNT);<br>Matrix C - DLY_IN; Matrix D - CLK<br>(DLY_OUT connected to nRST; nSET - HIGH)   |
|         |              | CNT/DLY → LUT   | 0001110: Matrix A - In3; Matrix B - In2; Matrix C - In1;<br>Matrix D - DLY_IN<br>(DLY_OUT connected to In0)                         |
|         |              | CNT/DLY → DFF   | 0011110: Matrix A - D; Matrix B - nSET; Matrix C - nRST;<br>Matrix D - DLY_IN<br>(DLY_OUT connected to CLK)                         |
|         |              | CNT/DLY → LUT   | 0101110: Matrix A - In3; Matrix B - EXT_CLK (CNT);<br>Matrix C - In1;<br>Matrix D - DLY_IN<br>(DLY_OUT connected to In0; In2 - LOW) |
|         |              | CNT/DLY → DFF   | 0111110: Matrix A - D; Matrix B - EXT_CLK (CNT);<br>Matrix C - nRST; Matrix D - DLY_IN<br>(DLY_OUT connected to CLK; nSET - HIGH)   |
|         |              | CNT/DLY → LUT   | 1001110: Matrix A - In3; Matrix B - In2; Matrix C - EXT_CLK (CNT);<br>Matrix D - DLY_IN<br>(DLY_OUT connected to In0; In1 - LOW)    |
|         |              | CNT/DLY → DFF   | 1011110: Matrix A - D; Matrix B - nSET; Matrix C - EXT_CLK (CNT);<br>Matrix D - DLY_IN<br>(DLY_OUT connected to CLK; nRST - HIGH)   |
|         |              | LUT → CNT/DLY   | 0000011: Matrix A - In3; Matrix B - In2; Matrix C - In1;<br>Matrix D - In0<br>(LUT_OUT connected to DLY_IN)                         |
|         |              | DFF → CNT/DLY   | 0010011: Matrix A - D; Matrix B - nSET; Matrix C - nRST;<br>Matrix D - CLK<br>(DFF_OUT connected to DLY_IN)                         |
|         |              | LUT → CNT/DLY   | 0100011: Matrix A - In3; Matrix B - EXT_CLK (CNT);<br>Matrix C - In1; Matrix D - In0<br>(LUT_OUT connected to DLY_IN; In2 - LOW)    |

**Auto AEC-Q100 Qualified GreenPAK Programmable Mixed-Signal Matrix**
**Table 57: Register Map (Continued)**

| Address |              | Signal Function                       | Register Bit Definition   |
|---------|--------------|---------------------------------------|---|
| Byte    | Register Bit |                                       |   |
| 80      | 1030:1024    | DFF → CNT/DLY                         | 0110011: Matrix A - D; Matrix B - EXT_CLK (CNT); Matrix C - nRST; Matrix D - CLK (DFF_OUT connected to DLY_IN; nSET - HIGH)   |
|         |              | LUT → CNT/DLY                         | 1000011: Matrix A - In3; Matrix B - In2; Matrix C - EXT_CLK (CNT); Matrix D - In0 (LUT_OUT connected to DLY_IN; In1 - LOW)  |
|         |              | DFF → CNT/DLY                         | 1010011: Matrix A - D; Matrix B - nSET; Matrix C - EXT_CLK (CNT); Matrix D - CLK (DFF_OUT connected to DLY_IN; nRST - HIGH)   |
|         | 1031         |                                       | 00: DLY<br>01: one shot<br>10: frequency det<br>11: CNT register [1040] = 0   |
| 81      | 1032         | DLY/CNT0 Mode Selection               | 00: both edge<br>01: falling edge<br>10: rising edge<br>11: High Level Reset (only in CNT mode)   |
|         | 1033         |                                       |   |
|         | 1034         | DLY/CNT0 edge Mode Selection          |   |
|         | 1035         | DLY/CNT0 Clock Source Select          | Clock source sel[3:0]<br>0000: 25M(OSC2);<br>0001: 25M/4;<br>0010: 2M(OSC1);<br>0011: 2M/8;<br>0100: 2M/64;<br>0101: 2M/512;<br>0110: 2K(OSC0);<br>0111: 2K/8;<br>1000: 2K/64;<br>1001: 2K/512;<br>1010: 2K/4096;<br>1011: 2K/32768;<br>1100: 2 K/262144;<br>1101: CNT7_END;<br>1110: External;<br>1111: Not used |
|         | 1036         |                                       |   |
|         | 1037         |                                       |   |
|         | 1038         |                                       |   |
|         | 1039         | FSM0 SET/RST Selection                | 0: Reset to 0<br>1: Set to data   |
| 82      | 1040         | CNT0 DLY EDET FUNCTION Selection      | 0: normal<br>1: DLY function edge detection (registers [1032:1031] = 00)  |
|         | 1041         | UP signal SYNC selection              | 0: bypass<br>1: after two DFF   |
|         | 1042         | Keep signal SYNC selection            | 0: bypass<br>1: after two DFF   |
|         | 1043         | CNT0 initial value selection          | 00: bypass the initial<br>01: initial 0<br>10: initial 1<br>11: initial 1   |
|         | 1044         |                                       |   |
|         | 1045         | Wake sleep power-down state selection | 0: low<br>1: high   |
|         | 1046         | wake sleep mode selection             | 0: Default Mode<br>1: Wake Sleep Mode (registers [1032:1031] = 11)  |
|         | 1047         | CNT0 output pol selection             | 0: Default Output<br>1: Inverted Output   |

**Auto AEC-Q100 Qualified GreenPAK Programmable Mixed-Signal Matrix**
**Table 57: Register Map (Continued)**

| Address |              | Signal Function   | Register Bit Definition  |   |
|---------|--------------|---|--|---|
| Byte    | Register Bit |   |  |   |
| 83      | 1048         | CNT0 CNT mode SYNC selection  | 0: bypass<br>1: after two DFF  |   |
|         | 1053:1049    | Single 3-bit LUT  | 00000: Matrix A - In2; Matrix B - In1;<br>Matrix C - In0<br>(DLY_IN - LOW)                                   |   |
|         |              | Single DFF w RST and SET  | 10000: Matrix A - D; Matrix B - nSET/nRST; Matrix C - CLK<br>(DLY_IN - LOW)                                  |   |
|         |              | Single CNT/DLY  | 00001: Matrix A - DLY_IN (CNT); Matrix B - EXT_CLK (CNT);<br>Matrix C - NC<br>(DLY_OUT connected to LUT/DFF) |   |
|         |              | CNT/DLY → LUT   | 00010: Matrix A - DLY_IN; Matrix B - In1; Matrix C - In0<br>(DLY_OUT connected to In2)                       |   |
|         |              | CNT/DLY → DFF   | 10010: Matrix A - DLY_IN; Matrix B - nSET/nRST;<br>Matrix C - CLK<br>(DLY_OUT connected to D)                |   |
|         |              | CNT/DLY → LUT   | 00110: Matrix A - In2; Matrix B - DLY_IN; Matrix C - In0<br>(DLY_OUT connected to In1)                       |   |
|         |              | CNT/DLY → DFF   | 10110: Matrix A - D; Matrix B - DLY_IN; Matrix C - CLK<br>(DLY_OUT connected to nSET/nRST)                   |   |
|         |              | CNT/DLY → LUT   | 01010: Matrix A - In2; Matrix B - In1;<br>Matrix C - DLY_IN<br>(DLY_OUT connected to In0)                    |   |
|         |              | CNT/DLY → DFF   | 11010: Matrix A - D; Matrix B - nSET/nRST; Matrix C - DLY_IN<br>(DLY_OUT connected to CLK)                   |   |
|         |              | LUT → CNT/DLY   | 00011: Matrix A - In2; Matrix B - In1; Matrix C - In0<br>(LUT_OUT connected to DLY_IN)                       |   |
|         |              | DFF → CNT/DLY   | 10011: Matrix A - D; Matrix B - nSET/nRST; Matrix C - CLK<br>(DFF_OUT connected to DLY_IN)                   |   |
|         |              | 1054  | CNT1 function and edge mode selection  | 0000: both edge Delay;<br>0001: falling edge delay;<br>0010: rising edge delay;<br>0011: both edge One Shot;<br>0100: falling edge One Shot;<br>0101: rising edge One Shot;<br>0110: both edge freq detect;<br>0111: falling edge freq detect;<br>1000: rising edge freq detect;<br>1001: both edge detect;<br>1010: falling edge detect;<br>1011: rising edge detect;<br>1100: both edge reset CNT;<br>1101: falling edge reset CNT;<br>1110: rising edge reset CNT;<br>1111: high level reset CNT |
|         | 1055         |   |  |   |
| 1056    |              |   |  |   |
| 84      | 1057         |   |  |   |
|         | 1058         | 00: bypass the initial  |  |   |
|         | 1059         | CNT1 initial value selection<br>01: initial 0<br>10: initial 1<br>11: initial 1 |  |   |

**Auto AEC-Q100 Qualified GreenPAK Programmable Mixed-Signal Matrix**
**Table 57: Register Map (Continued)**

| Address |               | Signal Function  | Register Bit Definition  |
|---------|---------------|--|--|
| Byte    | Register Bit  |  |  |
| 84      | 1060          | DLY/CNT1 Clock Source Select   | Clock source sel[3:0]<br>0000: 25M(OSC2);<br>0001: 25M/4;<br>0010: 2M(OSC1);<br>0011: 2M/8;<br>0100: 2M/64;<br>0101: 2M/512;<br>0110: 2K(OSC0);<br>0111: 2K/8;<br>1000: 2K/64;<br>1001: 2K/512;<br>1010: 2K/4096;<br>1011: 2K/32768;<br>1100: 2K/262144;<br>1101: CNT0_END;<br>1110: External;<br>1111: Not used |
|         | 1061          |  |  |
|         | 1062          |  |  |
|         | 1063          |  |  |
| 85      | 1064          | CNT1 output pol selection  | 0: Default Output<br>1: Inverted Output  |
|         | 1065          | CNT1 CNT mode SYNC selection   | 0: bypass<br>1: after two DFF  |
|         | 1066          | CNT1 DLY EDET FUNCTION Selection   | 0: normal<br>1: DLY function edge detection<br>(registers[1057:1054]=0000/0001/0010)   |
|         | 1071:1067     | Single 3-bit LUT   | 00000: Matrix A - In2; Matrix B - In1;<br>Matrix C - In0<br>(DLY_IN - LOW)   |
|         |               | Single DFF w RST and SET   | 10000: Matrix A - D; Matrix B - nSET/nRST; Matrix C - CLK<br>(DLY_IN - LOW)  |
|         |               | Single CNT/DLY   | 00001: Matrix A - DLY_IN (CNT); Matrix B - EXT_CLK (CNT);<br>Matrix C - NC<br>(DLY_OUT connected to LUT/DFF)   |
|         |               | CNT/DLY → LUT  | 00010: Matrix A - DLY_IN; Matrix B - In1; Matrix C - In0<br>(DLY_OUT connected to In2)   |
|         |               | CNT/DLY → DFF  | 10010: Matrix A - DLY_IN; Matrix B - nSET/nRST;<br>Matrix C - CLK<br>(DLY_OUT connected to D)  |
|         |               | CNT/DLY → LUT  | 00110: Matrix A - In2; Matrix B - DLY_IN; Matrix C - In0<br>(DLY_OUT connected to In1)   |
|         |               | CNT/DLY → DFF  | 10110: Matrix A - D; Matrix B - DLY_IN; Matrix C - CLK<br>(DLY_OUT connected to nSET/nRST)   |
|         |               | CNT/DLY → LUT  | 01010: Matrix A - In2; Matrix B - In1;<br>Matrix C - DLY_IN<br>(DLY_OUT connected to In0)  |
|         |               | CNT/DLY → DFF  | 11010: Matrix A - D; Matrix B - nSET/nRST; Matrix C - DLY_IN<br>(DLY_OUT connected to CLK)   |
|         |               | LUT → CNT/DLY  | 00011: Matrix A - In2; Matrix B - In1; Matrix C - In0<br>(LUT_OUT connected to DLY_IN)   |
|         | DFF → CNT/DLY | 10011: Matrix A - D; Matrix B - nSET/nRST; Matrix C - CLK<br>(DFF_OUT connected to DLY_IN) |  |

**Auto AEC-Q100 Qualified GreenPAK Programmable  
Mixed-Signal Matrix**
**Table 57: Register Map (Continued)**

| Address |              | Signal Function                       | Register Bit Definition   |
|---------|--------------|---------------------------------------|---|
| Byte    | Register Bit |                                       |   |
| 86      | 1072         | CNT2 initial value selection          | 00: bypass the initial<br>01: initial 0<br>10: initial 1<br>11: initial 1   |
|         | 1073         |                                       |   |
|         | 1074         | CNT2 function and edge mode selection | 0000: both edge Delay;<br>0001: falling edge delay;<br>0010: rising edge delay;<br>0011: both edge One Shot;<br>0100: falling edge One Shot;<br>0101: rising edge One Shot;<br>0110: both edge freq detect;<br>0111: falling edge freq detect;<br>1000: rising edge freq detect;<br>1001: both edge detect;<br>1010: falling edge detect;<br>1011: rising edge detect;<br>1100: both edge reset CNT;<br>1101: falling edge reset CNT;<br>1110: rising edge reset CNT;<br>1111: high level reset CNT |
|         | 1075         |                                       |   |
|         | 1076         |                                       |   |
|         | 1077         |                                       |   |
|         | 1078         | DLY/CNT2 Clock Source Select          | Clock source sel[3:0]<br>0000: 25M(OSC2);<br>0001: 25M/4;<br>0010: 2M(OSC1);<br>0011: 2M/8;<br>0100: 2M/64;<br>0101: 2M/512;<br>0110: 2K(OSC0);<br>0111: 2K/8;<br>1000: 2K/64;<br>1001: 2K/512;<br>1010: 2K/4096;<br>1011: 2K/32768;<br>1100: 2K/262144;<br>1101: CNT1_END;<br>1110: External;<br>1111: Not used  |
| 1079    |              |                                       |   |
| 1080    |              |                                       |   |
| 87      | 1081         |                                       |   |
|         | 1082         | CNT2 output pol selection             | 0: Default Output, 1: Inverted Output   |
|         | 1083         | CNT2 CNT mode SYNC selection          | 0: bypass; 1: after two DFF   |
|         | 1084         | CNT2 DLY EDET FUNCTION Selection      | 0: normal; 1: DLY function edge detection(registers[1077:1074] = 0000/0001/0010)  |
|         | 1085         | CNT3 initial value selection          | 00:bypass the initial; 01: initial 0; 10: initial 1; 11: initial 1  |
|         | 1086         |                                       |   |
|         | 1087         | Multi3 register configure             | refer to byte 88  |
| 88      | 1088         | CNT3 function and edge mode selection | 0000: both edge Delay;<br>0001: falling edge delay;<br>0010: rising edge delay;<br>0011: both edge One Shot;<br>0100: falling edge One Shot;<br>0101: rising edge One Shot;<br>0110: both edge freq detect;<br>0111: falling edge freq detect;<br>1000: rising edge freq detect;<br>1001: both edge detect;<br>1010: falling edge detect;<br>1011: rising edge detect;<br>1100: both edge reset CNT;<br>1101: falling edge reset CNT;<br>1110: rising edge reset CNT;<br>1111: high level reset CNT |
|         | 1089         |                                       |   |
|         | 1090         |                                       |   |
|         | 1091         |                                       |   |

**Auto AEC-Q100 Qualified GreenPAK Programmable Mixed-Signal Matrix**
**Table 57: Register Map (Continued)**

| Address |                                  | Signal Function  | Register Bit Definition   |
|---------|----------------------------------|--|---|
| Byte    | Register Bit                     |  |   |
| 88      | 1087,<br>1093:1092,<br>1095:1094 | Single 3-bit LUT   | 00000: Matrix A - In2; Matrix B - In1;<br>Matrix C - In0<br>(DLY_IN - LOW)  |
|         |                                  | Single DFF w RST and SET   | 10000: Matrix A - D; Matrix B - nSET/nRST; Matrix C - CLK<br>(DLY_IN - LOW)   |
|         |                                  | Single CNT/DLY   | 00001: Matrix A - DLY_IN (CNT); Matrix B - EXT_CLK (CNT);<br>Matrix C - NC<br>(DLY_OUT connected to LUT/DFF)  |
|         |                                  | CNT/DLY → LUT  | 00010: Matrix A - DLY_IN; Matrix B - In1; Matrix C - In0<br>(DLY_OUT connected to In2)  |
|         |                                  | CNT/DLY → DFF  | 10010: Matrix A - DLY_IN; Matrix B - nSET/nRST;<br>Matrix C - CLK<br>(DLY_OUT connected to D)   |
|         |                                  | CNT/DLY → LUT  | 00110: Matrix A - In2; Matrix B - DLY_IN; Matrix C - In0<br>(DLY_OUT connected to In1)  |
|         |                                  | CNT/DLY → DFF  | 10110: Matrix A - D; Matrix B - DLY_IN; Matrix C - CLK<br>(DLY_OUT connected to nSET/nRST)  |
|         |                                  | CNT/DLY → LUT  | 01010: Matrix A - In2; Matrix B - In1;<br>Matrix C - DLY_IN<br>(DLY_OUT connected to In0)   |
|         |                                  | CNT/DLY → DFF  | 11010: Matrix A - D; Matrix B - nSET/nRST; Matrix C - DLY_IN<br>(DLY_OUT connected to CLK)  |
|         |                                  | LUT → CNT/DLY  | 00011: Matrix A - In2; Matrix B - In1; Matrix C - In0<br>(LUT_OUT connected to DLY_IN)  |
|         |                                  | DFF → CNT/DLY  | 10011: Matrix A - D; Matrix B - nSET/nRST; Matrix C - CLK<br>(DFF_OUT connected to DLY_IN)  |
| 89      | 1096                             | DLY/CNT3 Clock Source Select   | Clock source sel[3:0]   |
|         | 1097                             |  | 0000: 25M(OSC2); 0001: 25M/4;   |
|         | 1098                             |  | 0010: 2M(OSC1); 0011: 2M/8;   |
|         | 1099                             |  | 0100: 2M/64; 0101: 2M/512;  |
|         |                                  |  | 0110: 2K(OSC0); 0111: 2K/8;<br>1000: 2K/64; 1001: 2K/512;<br>1010: 2K/4096; 1011: 2K/32768;<br>1100: 2K/262144; 1101: CNT2_END;<br>1110: External; 1111: Not used |
| 1100    | CNT3 output pol selection        | 0: Default Output<br>1: Inverted Output  |   |
| 1101    | CNT3 CNT mode SYNC selection     | 0: bypass<br>1: after two DFF  |   |
| 1102    | CNT3 DLY EDET FUNCTION Selection | 0: normal<br>1: DLY function edge detection<br>(registers[1091:1088]=0000/0001/0010) |   |
| 1103    | CNT4 CNT mode SYNC selection     | 0: bypass<br>1: after two DFF  |   |

**Auto AEC-Q100 Qualified GreenPAK Programmable Mixed-Signal Matrix**
**Table 57: Register Map (Continued)**

| Address |              | Signal Function                  | Register Bit Definition  |  |
|---------|--------------|----------------------------------|--|--|
| Byte    | Register Bit |                                  |  |  |
| 8A      | 1104         | CNT4 initial value selection     | 00: bypass the initial<br>01: initial 0<br>10: initial 1<br>11: initial 1  |  |
|         | 1105         |                                  |  |  |
|         | 1106         | CNT4 DLY EDET FUNCTION Selection | 0: normal<br>1: DLY function edge detection<br>(registers[1119:1116]=0000/0001/0010)   |  |
|         | 1111:1107    |                                  | Single 3-bit LUT   | 00000: Matrix A - In2; Matrix B - In1;<br>Matrix C - In0<br>(DLY_IN - LOW)                                   |
|         |              |                                  | Single DFF w RST and SET   | 10000: Matrix A - D; Matrix B - nSET/nRST; Matrix C - CLK<br>(DLY_IN - LOW)                                  |
|         |              |                                  | Single CNT/DLY   | 00001: Matrix A - DLY_IN (CNT); Matrix B - EXT_CLK (CNT);<br>Matrix C - NC<br>(DLY_OUT connected to LUT/DFF) |
|         |              |                                  | CNT/DLY → LUT  | 00010: Matrix A - DLY_IN; Matrix B - In1; Matrix C - In0<br>(DLY_OUT connected to In2)                       |
|         |              |                                  | CNT/DLY → DFF  | 10010: Matrix A - DLY_IN; Matrix B - nSET/nRST;<br>Matrix C - CLK<br>(DLY_OUT connected to D)                |
|         |              |                                  | CNT/DLY → LUT  | 00110: Matrix A - In2; Matrix B - DLY_IN; Matrix C - In0<br>(DLY_OUT connected to In1)                       |
|         |              |                                  | CNT/DLY → DFF  | 10110: Matrix A - D; Matrix B - DLY_IN; Matrix C - CLK<br>(DLY_OUT connected to nSET/nRST)                   |
|         |              |                                  | CNT/DLY → LUT  | 01010: Matrix A - In2; Matrix B - In1;<br>Matrix C - DLY_IN<br>(DLY_OUT connected to In0)                    |
|         |              |                                  | CNT/DLY → DFF  | 11010: Matrix A - D; Matrix B - nSET/nRST; Matrix C - DLY_IN<br>(DLY_OUT connected to CLK)                   |
|         |              |                                  | LUT → CNT/DLY  | 00011: Matrix A - In2; Matrix B - In1; Matrix C - In0<br>(LUT_OUT connected to DLY_IN)                       |
|         |              | DFF → CNT/DLY                    | 10011: Matrix A - D; Matrix B - nSET/nRST; Matrix C - CLK<br>(DFF_OUT connected to DLY_IN)   |  |
| 8B      | 1112         | DLY/CNT4 Clock Source Select     | Clock source sel[3:0]<br>0000: 25M(OSC2);<br>0001: 25M/4;<br>0010: 2M(OSC1);<br>0011: 2M/8;<br>0100: 2M/64;<br>0101: 2M/512;<br>0110: 2K(OSC0);<br>0111: 2K/8;<br>1000: 2K/64;<br>1001: 2K/512;<br>1010: 2K/4096;<br>1011: 2K/32768;<br>1100: 2K/262144;<br>1101: CNT3_END;<br>1110: External;<br>1111: Not used |  |
|         | 1113         |                                  |  |  |
|         | 1114         |                                  |  |  |
|         | 1115         |                                  |  |  |
|         |              |                                  |  |  |

**Auto AEC-Q100 Qualified GreenPAK Programmable Mixed-Signal Matrix**
**Table 57: Register Map (Continued)**

| Address       |   | Signal Function                       | Register Bit Definition   |
|---------------|---|---------------------------------------|---|
| Byte          | Register Bit  |                                       |   |
| 8B            | 1116  | CNT4 function and edge mode selection | 0000: both edge Delay;<br>0001: falling edge delay;<br>0010: rising edge delay;<br>0011: both edge One Shot;<br>0100: falling edge One Shot;<br>0101: rising edge One Shot;<br>0110: both edge freq detect;<br>0111: falling edge freq detect;<br>1000: rising edge freq detect;<br>1001: both edge detect;<br>1010: falling edge detect;<br>1011: rising edge detect;<br>1100: both edge reset CNT;<br>1101: falling edge reset CNT;<br>1110: rising edge reset CNT;<br>1111: high level reset CNT |
|               | 1117  |                                       |   |
|               | 1118  |                                       |   |
|               | 1119  |                                       |   |
| 8C            | 1120  | CNT4 output pol selection             | 0: Default Output<br>1: Inverted Output   |
|               | 1121  | CNT5 function and edge mode selection | 0000: both edge Delay;<br>0001: falling edge delay;<br>0010: rising edge delay;<br>0011: both edge One Shot;<br>0100: falling edge One Shot;<br>0101: rising edge One Shot;<br>0110: both edge freq detect;<br>0111: falling edge freq detect;<br>1000: rising edge freq detect;<br>1001: both edge detect;<br>1010: falling edge detect;<br>1011: rising edge detect;<br>1100: both edge reset CNT;<br>1101: falling edge reset CNT;<br>1110: rising edge reset CNT;<br>1111: high level reset CNT |
|               | 1122  |                                       |   |
|               | 1123  |                                       |   |
|               | 1124  |                                       |   |
|               | 1125  | CNT5 output pol selection             | 0: Default Output<br>1: Inverted Output   |
|               | 1134,<br>1127:1126,<br>1133:1132  | Single 3-bit LUT                      | 00000: Matrix A - In2; Matrix B - In1;<br>Matrix C - In0<br>(DLY_IN - LOW)  |
|               |   | Single DFF w RST and SET              | 10000: Matrix A - D; Matrix B - nSET/nRST; Matrix C - CLK<br>(DLY_IN - LOW)   |
|               |   | Single CNT/DLY                        | 00001: Matrix A - DLY_IN (CNT); Matrix B - EXT_CLK (CNT);<br>Matrix C - NC<br>(DLY_OUT connected to LUT/DFF)  |
|               |   | CNT/DLY → LUT                         | 00010: Matrix A - DLY_IN; Matrix B - In1; Matrix C - In0<br>(DLY_OUT connected to In2)  |
|               |   | CNT/DLY → DFF                         | 10010: Matrix A - DLY_IN; Matrix B - nSET/nRST;<br>Matrix C - CLK<br>(DLY_OUT connected to D)   |
|               |   | CNT/DLY → LUT                         | 00110: Matrix A - In2; Matrix B - DLY_IN; Matrix C - In0<br>(DLY_OUT connected to In1)  |
|               |   | CNT/DLY → DFF                         | 10110: Matrix A - D; Matrix B - DLY_IN; Matrix C - CLK<br>(DLY_OUT connected to nSET/nRST)  |
| CNT/DLY → LUT | 01010: Matrix A - In2; Matrix B - In1;<br>Matrix C - DLY_IN<br>(DLY_OUT connected to In0) |                                       |   |



**Auto AEC-Q100 Qualified GreenPAK Programmable Mixed-Signal Matrix**
**Table 57: Register Map (Continued)**

| Address |                                  | Signal Function                       | Register Bit Definition   |
|---------|----------------------------------|---------------------------------------|---|
| Byte    | Register Bit                     |                                       |   |
| 8C      | 1134,<br>1127:1126,<br>1133:1132 | CNT/DLY → DFF                         | 11010: Matrix A - D; Matrix B - nSET/nRST; Matrix C - DLY_IN (DLY_OUT connected to CLK)   |
|         |                                  | LUT → CNT/DLY                         | 00011: Matrix A - In2; Matrix B - In1; Matrix C - In0 (LUT_OUT connected to DLY_IN)   |
|         |                                  | DFF → CNT/DLY                         | 10011: Matrix A - D; Matrix B - nSET/nRST; Matrix C - CLK (DFF_OUT connected to DLY_IN)   |
| 8D      | 1128                             | DLY/CNT5 Clock Source Select          | Clock source sel[3:0]<br>0000: 25M(OSC2);<br>0001: 25M/4;<br>0010: 2M(OSC1);<br>0011:2M/8;<br>0100: 2M/64;<br>0101: 2M/512;<br>0110:2K(OSC0);<br>0111: 2K/8;<br>1000:2K/64;<br>1001: 2K/512;<br>1010: 2K/4096;<br>1011:2K/32768;<br>1100: 2K/262144;<br>1101: CNT4_END;<br>1110: External;<br>1111: Not used  |
|         | 1129                             |                                       |   |
|         | 1130                             |                                       |   |
|         | 1131                             |                                       |   |
|         | 1135                             | CNT5 DLY EDET FUNCTION Selection      | 0: normal;<br>1: DLY function edge detection (registers[1124:1121]=0000/0001/0010)  |
| 8E      | 1136                             | CNT5 CNT mode SYNC selection          | 0: bypass;<br>1: after two DFF  |
|         | 1137                             | CNT5 initial value selection          | 00: bypass the initial<br>01: initial 0<br>10: initial 1<br>11: initial 1   |
|         | 1138                             |                                       |   |
|         | 1139                             | CNT6 function and edge mode selection | 0000: both edge Delay;<br>0001: falling edge delay;<br>0010: rising edge delay;<br>0011: both edge One Shot;<br>0100: falling edge One Shot;<br>0101: rising edge One Shot;<br>0110: both edge freq detect;<br>0111: falling edge freq detect;<br>1000: rising edge freq detect;<br>1001: both edge detect;<br>1010: falling edge detect;<br>1011: rising edge detect;<br>1100: both edge reset CNT;<br>1101: falling edge reset CNT;<br>1110: rising edge reset CNT;<br>1111: high level reset CNT |
|         | 1140                             |                                       |   |
|         | 1141                             |                                       |   |
|         | 1142                             |                                       |   |
|         | 1143                             | CNT6 output pol selection             | 0: Default Output<br>1: Inverted Output   |

**Auto AEC-Q100 Qualified GreenPAK Programmable Mixed-Signal Matrix**
**Table 57: Register Map (Continued)**

| Address |                                  | Signal Function  | Register Bit Definition  |                               |                          |  |
|---------|----------------------------------|--|--|-------------------------------|--------------------------|--|
| Byte    | Register Bit                     |  |  |                               |                          |  |
| 8F      | 1144                             | DLY/CNT6 Clock Source Select   | Clock source sel[3:0]<br>0000: 25M(OSC2);<br>0001: 25M/4;<br>0010: 2M(OSC1);<br>0011: 2M/8;<br>0100: 2M/64;<br>0101: 2M/512;<br>0110: 2K(OSC0);<br>0111: 2K/8;<br>1000: 2K/64;<br>1001: 2K/512;<br>1010: 2K/4096;<br>1011: 2K/32768;<br>1100: 2K/262144;<br>1101: CNT5_END;<br>1110: External;<br>1111: Not used |                               |                          |  |
|         | 1145                             |  |  |                               |                          |  |
|         | 1146                             |  |  |                               |                          |  |
|         | 1152,<br>1149:1148,<br>1151:1150 |  |  |                               | Single 3-bit LUT         | 00000: Matrix A - In2; Matrix B - In1;<br>Matrix C - In0<br>(DLY_IN - LOW)                                   |
|         |                                  |  |  |                               | Single DFF w RST and SET | 10000: Matrix A - D; Matrix B - nSET/nRST; Matrix C - CLK<br>(DLY_IN - LOW)                                  |
|         |                                  |  |  |                               | Single CNT/DLY           | 00001: Matrix A - DLY_IN (CNT); Matrix B - EXT_CLK (CNT);<br>Matrix C - NC<br>(DLY_OUT connected to LUT/DFF) |
|         |                                  |  |  |                               | CNT/DLY → LUT            | 00010: Matrix A - DLY_IN; Matrix B - In1; Matrix C - In0<br>(DLY_OUT connected to In2)                       |
|         |                                  |  |  |                               | CNT/DLY → DFF            | 10010: Matrix A - DLY_IN; Matrix B - nSET/nRST;<br>Matrix C - CLK<br>(DLY_OUT connected to D)                |
|         |                                  |  |  |                               | CNT/DLY → LUT            | 00110: Matrix A - In2; Matrix B - DLY_IN; Matrix C - In0<br>(DLY_OUT connected to In1)                       |
|         |                                  |  |  |                               | CNT/DLY → DFF            | 10110: Matrix A - D; Matrix B - DLY_IN; Matrix C - CLK<br>(DLY_OUT connected to nSET/nRST)                   |
|         |                                  |  |  |                               | CNT/DLY → LUT            | 01010: Matrix A - In2; Matrix B - In1;<br>Matrix C - DLY_IN<br>(DLY_OUT connected to In0)                    |
|         |                                  |  |  |                               | CNT/DLY → DFF            | 11010: Matrix A - D; Matrix B - nSET/nRST; Matrix C - DLY_IN<br>(DLY_OUT connected to CLK)                   |
|         |                                  |  |  |                               | LUT → CNT/DLY            | 00011: Matrix A - In2; Matrix B - In1; Matrix C - In0<br>(LUT_OUT connected to DLY_IN)                       |
|         | DFF → CNT/DLY                    | 10011: Matrix A - D; Matrix B - nSET/nRST; Matrix C - CLK<br>(DFF_OUT connected to DLY_IN) |  |                               |                          |  |
| 90      | 1153                             | CNT6 DLY EDET FUNCTION Selection   | 0: normal<br>1: DLY function edge detection (registers[1142:1139]=0000/<br>0001/0010)  |                               |                          |  |
|         | 1154                             | CNT6 CNT mode SYNC selection   | 0: bypass<br>1: after two DFF  |                               |                          |  |
|         | 1155                             | CNT6 initial value selection   | 00: bypass the initial<br>01: initial 0<br>10: initial 1<br>11: initial 1  |                               |                          |  |
|         | 1156                             |  |  |                               |                          |  |
| 90      | 1157                             | CNT7 initial value selection   | 00: bypass the initial<br>01: initial 0<br>10: initial 1<br>11: initial 1  |                               |                          |  |
|         | 1158                             |  |  |                               |                          |  |
|         | 1159                             |  | CNT7 CNT mode SYNC selection   | 0: bypass<br>1: after two DFF |                          |  |

**Auto AEC-Q100 Qualified GreenPAK Programmable Mixed-Signal Matrix**
**Table 57: Register Map (Continued)**

| Address |                 | Signal Function                  | Register Bit Definition  |
|---------|-----------------|----------------------------------|--|
| Byte    | Register Bit    |                                  |  |
| 91      | 1160            | CNT7 DLY EDET FUNCTION Selection | 0: normal<br>1: DLY function edge detection (registers [1174:1171]=0000/0001/0010)                     |
|         | 1161, 1165:1162 | Single 3-bit LUT                 | 00000: Matrix A - In2; Matrix B - In1; Matrix C - In0 (DLY_IN - LOW)                                   |
|         |                 | Single DFF w RST and SET         | 10000: Matrix A - D; Matrix B - nSET/nRST; Matrix C - CLK (DLY_IN - LOW)                               |
|         |                 | Single CNT/DLY                   | 00001: Matrix A - DLY_IN (CNT); Matrix B - EXT_CLK (CNT); Matrix C - NC (DLY_OUT connected to LUT/DFF) |
|         |                 | CNT/DLY → LUT                    | 00010: Matrix A - DLY_IN; Matrix B - In1; Matrix C - In0 (DLY_OUT connected to In2)                    |
|         |                 | CNT/DLY → DFF                    | 10010: Matrix A - DLY_IN; Matrix B - nSET/nRST; Matrix C - CLK (DLY_OUT connected to D)                |
|         |                 | CNT/DLY → LUT                    | 00110: Matrix A - In2; Matrix B - DLY_IN; Matrix C - In0 (DLY_OUT connected to In1)                    |
|         |                 | CNT/DLY → DFF                    | 10110: Matrix A - D; Matrix B - DLY_IN; Matrix C - CLK (DLY_OUT connected to nSET/nRST)                |
|         |                 | CNT/DLY → LUT                    | 01010: Matrix A - In2; Matrix B - In1; Matrix C - DLY_IN (DLY_OUT connected to In0)                    |
|         |                 | CNT/DLY → DFF                    | 11010: Matrix A - D; Matrix B - nSET/nRST; Matrix C - DLY_IN (DLY_OUT connected to CLK)                |
|         |                 | LUT → CNT/DLY                    | 00011: Matrix A - In2; Matrix B - In1; Matrix C - In0 (LUT_OUT connected to DLY_IN)                    |
|         |                 | DFF → CNT/DLY                    | 10011: Matrix A - D; Matrix B - nSET/nRST; Matrix C - CLK (DFF_OUT connected to DLY_IN)                |

**Auto AEC-Q100 Qualified GreenPAK Programmable Mixed-Signal Matrix**
**Table 57: Register Map (Continued)**

| Address |              | Signal Function                       | Register Bit Definition   |
|---------|--------------|---------------------------------------|---|
| Byte    | Register Bit |                                       |   |
| 91      | 1166         | DLY/CNT7 Clock Source Select          | Clock source sel[3:0]<br>0000: 25M(OSC2);<br>0001: 25M/4;<br>0010: 2M(OSC1);<br>0011: 2M/8;<br>0100: 2M/64;<br>0101: 2M/512;<br>0110: 2K(OSC0);<br>0111: 2K/8;<br>1000: 2K/64;<br>1001: 2K/512;<br>1010: 2K/4096;<br>1011: 2K/32768;<br>1100: 2K/262144;<br>1101: CNT6_END;<br>1110: External;<br>1111: Not used  |
|         | 1167         |                                       |   |
|         | 1168         |                                       |   |
| 92      | 1169         |                                       |   |
|         | 1170         | CNT7 output pol selection             | 0: Default Output<br>1: Inverted Output   |
|         | 1171         | CNT7 function and edge mode selection | 0000: both edge Delay;<br>0001: falling edge delay;<br>0010: rising edge delay;<br>0011: both edge One Shot;<br>0100: falling edge One Shot;<br>0101: rising edge One Shot;<br>0110: both edge freq detect;<br>0111: falling edge freq detect;<br>1000: rising edge freq detect;<br>1001: both edge detect;<br>1010: falling edge detect;<br>1011: rising edge detect;<br>1100: both edge reset CNT;<br>1101: falling edge reset CNT;<br>1110: rising edge reset CNT;<br>1111: high level reset CNT |
|         | 1172         |                                       |   |
|         | 1173         |                                       |   |
| 1174    |              |                                       |   |
| 1175    | Reserved     |                                       |   |
| 93      | 1176         | Multi0_LUT4_DFF setting               | [15]:LUT4_1 [15]/DFF20 or LATCH Select<br>0: DFF function, 1: LATCH function<br>[14]:LUT4_1 [14]/DFF20 Output Select<br>0: Q output, 1: QB output<br>[13]:LUT4_1 [13]/DFF20 Initial Polarity Select<br>0: Low, 1: High<br>[12:0]:LUT4_1 [12:0]  |
|         | 1177         |                                       |   |
|         | 1178         |                                       |   |
|         | 1179         |                                       |   |
|         | 1180         |                                       |   |
|         | 1181         |                                       |   |
|         | 1182         |                                       |   |
|         | 1183         |                                       |   |
| 94      | 1184         |                                       |   |
|         | 1185         |                                       |   |
|         | 1186         |                                       |   |
|         | 1187         |                                       |   |
|         | 1188         |                                       |   |
|         | 1189         |                                       |   |
|         | 1190         |                                       |   |
|         | 1191         |                                       |   |

# SLG46855-A

## Auto AEC-Q100 Qualified GreenPAK Programmable Mixed-Signal Matrix

**Table 57: Register Map (Continued)**

| Address |              | Signal Function         | Register Bit Definition  |
|---------|--------------|-------------------------|--|
| Byte    | Register Bit |                         |  |
| 95      | 1192         | REG_CNT0_D[15:0]        | Data[15:0]   |
|         | 1193         |                         |  |
|         | 1194         |                         |  |
|         | 1195         |                         |  |
|         | 1196         |                         |  |
|         | 1197         |                         |  |
|         | 1198         |                         |  |
|         | 1199         |                         |  |
| 96      | 1200         | REG_CNT0_D[15:0]        | Data[15:0]   |
|         | 1201         |                         |  |
|         | 1202         |                         |  |
|         | 1203         |                         |  |
|         | 1204         |                         |  |
|         | 1205         |                         |  |
|         | 1206         |                         |  |
|         | 1207         |                         |  |
| 97      | 1208         | Multi1_LUT3_DFF setting | [7]:LUT3_9 [7]/DFF13 or LATCH Select<br>0: DFF function, 1: LATCH function<br>[6]:LUT3_9 [6]/DFF13 Output Select<br>0: Q output, 1: QB output<br>[5]:LUT3_9 [5]/DFF13<br>0: nRST from Matrix Output, 1: nSET from Matrix Output<br>[4]:LUT3_9 [4]/DFF13 Initial Polarity Select<br>0: Low, 1: High<br>[3:0]:LUT3_9 [3:0]     |
|         | 1209         |                         |  |
|         | 1210         |                         |  |
|         | 1211         |                         |  |
|         | 1212         |                         |  |
|         | 1213         |                         |  |
|         | 1214         |                         |  |
|         | 1215         |                         |  |
| 98      | 1216         | REG_CNT1_D[7:0]         | Data[7:0]  |
|         | 1217         |                         |  |
|         | 1218         |                         |  |
|         | 1219         |                         |  |
|         | 1220         |                         |  |
|         | 1221         |                         |  |
|         | 1222         |                         |  |
|         | 1223         |                         |  |
| 99      | 1224         | Multi2_LUT3_DFF setting | [7]:LUT3_10 [7]/DFF14 or LATCH Select<br>0: DFF function, 1: LATCH function<br>[6]:LUT3_10[6]/DFF14 Output Select<br>0: Q output, 1: QB output<br>[5]:LUT3_10 [5]/DFF14<br>0: nRST from Matrix Output, 1: nSET from Matrix Output<br>[4]:LUT3_10 [4]/DFF14 Initial Polarity Select<br>0: Low, 1: High<br>[3:0]:LUT3_10 [3:0] |
|         | 1225         |                         |  |
|         | 1226         |                         |  |
|         | 1227         |                         |  |
|         | 1228         |                         |  |
|         | 1229         |                         |  |
|         | 1230         |                         |  |
|         | 1231         |                         |  |
| 9A      | 1232         | REG_CNT2_D[7:0]         | Data[7:0]  |
|         | 1233         |                         |  |
|         | 1234         |                         |  |
|         | 1235         |                         |  |
|         | 1236         |                         |  |
|         | 1237         |                         |  |
|         | 1238         |                         |  |
|         | 1239         |                         |  |

**Auto AEC-Q100 Qualified GreenPAK Programmable  
Mixed-Signal Matrix**
**Table 57: Register Map (Continued)**

| Address |              | Signal Function         | Register Bit Definition  |
|---------|--------------|-------------------------|--|
| Byte    | Register Bit |                         |  |
| 9B      | 1240         | Multi3_LUT3_DFF setting | [7]:LUT3_11 [7]/DFF15 or LATCH Select<br>0: DFF function, 1: LATCH function<br>[6]:LUT3_11[6]/DFF15 Output Select<br>0: Q output, 1: QB output<br>[5]:LUT3_11 [5]/DFF15<br>0: nRST from Matrix Output, 1: nSET from Matrix Output<br>[4]:LUT3_11 [4]/DFF15 Initial Polarity Select<br>0: Low, 1: High<br>[3:0]:LUT3_11 [3:0] |
|         | 1241         |                         |  |
|         | 1242         |                         |  |
|         | 1243         |                         |  |
|         | 1244         |                         |  |
|         | 1245         |                         |  |
|         | 1246         |                         |  |
|         | 1247         |                         |  |
| 9C      | 1248         | REG_CNT3_D[7:0]         | Data[7:0]  |
|         | 1249         |                         |  |
|         | 1250         |                         |  |
|         | 1251         |                         |  |
|         | 1252         |                         |  |
|         | 1253         |                         |  |
|         | 1254         |                         |  |
|         | 1255         |                         |  |
| 9D      | 1256         | Multi4_LUT3_DFF setting | [7]:LUT3_12 [7]/DFF16 or LATCH Select<br>0: DFF function, 1: LATCH function<br>[6]:LUT3_12[6]/DFF16 Output Select<br>0: Q output, 1: QB output<br>[5]:LUT3_12 [5]/DFF16<br>0: nRST from Matrix Output, 1: nSET from Matrix Output<br>[4]:LUT3_12 [4]/DFF16 Initial Polarity Select<br>0: Low, 1: High<br>[3:0]:LUT3_12 [3:0] |
|         | 1257         |                         |  |
|         | 1258         |                         |  |
|         | 1259         |                         |  |
|         | 1260         |                         |  |
|         | 1261         |                         |  |
|         | 1262         |                         |  |
|         | 1263         |                         |  |
| 9E      | 1264         | REG_CNT4_D[7:0]         | Data[7:0]  |
|         | 1265         |                         |  |
|         | 1266         |                         |  |
|         | 1267         |                         |  |
|         | 1268         |                         |  |
|         | 1269         |                         |  |
|         | 1270         |                         |  |
|         | 1271         |                         |  |
| 9F      | 1272         | Multi5_LUT3_DFF setting | [7]:LUT3_13 [7]/DFF17 or LATCH Select<br>0: DFF function, 1: LATCH function<br>[6]:LUT3_13[6]/DFF17 Output Select<br>0: Q output, 1: QB output<br>[5]:LUT3_13 [5]/DFF17<br>0: nRST from Matrix Output, 1: nSET from Matrix Output<br>[4]:LUT3_13 [4]/DFF17 Initial Polarity Select<br>0: Low, 1: High<br>[3:0]:LUT3_13 [3:0] |
|         | 1273         |                         |  |
|         | 1274         |                         |  |
|         | 1275         |                         |  |
|         | 1276         |                         |  |
|         | 1277         |                         |  |
|         | 1278         |                         |  |
|         | 1279         |                         |  |
| A0      | 1280         | REG_CNT5_D[7:0]         | Data[7:0]  |
|         | 1281         |                         |  |
|         | 1282         |                         |  |
|         | 1283         |                         |  |
|         | 1284         |                         |  |
|         | 1285         |                         |  |
|         | 1286         |                         |  |
|         | 1287         |                         |  |

# SLG46855-A

## Auto AEC-Q100 Qualified GreenPAK Programmable Mixed-Signal Matrix

**Table 57: Register Map (Continued)**

| Address |              | Signal Function             | Register Bit Definition  |  |  |
|---------|--------------|-----------------------------|--|--|--|
| Byte    | Register Bit |                             |  |  |  |
| A1      | 1288         | Multi6_LUT3_DFF setting     | [7]:LUT3_14 [7]/DFF18 or LATCH Select<br>0: DFF function, 1: LATCH function<br>[6]:LUT3_14[6]/DFF18 Output Select<br>0: Q output, 1: QB output<br>[5]:LUT3_14 [5]/DFF18<br>0: nRST from Matrix Output, 1: nSET from Matrix Output<br>[4]:LUT3_14 [4]/DFF18 Initial Polarity Select<br>0: Low, 1: High<br>[3:0]:LUT3_14 [3:0] |  |  |
|         | 1289         |                             |  |  |  |
|         | 1290         |                             |  |  |  |
|         | 1291         |                             |  |  |  |
|         | 1292         |                             |  |  |  |
|         | 1293         |                             |  |  |  |
|         | 1294         |                             |  |  |  |
|         | 1295         |                             |  |  |  |
| A2      | 1296         | REG_CNT6_D[7:0]             | Data[7:0]  |  |  |
|         | 1297         |                             |  |  |  |
|         | 1298         |                             |  |  |  |
|         | 1299         |                             |  |  |  |
|         | 1300         |                             |  |  |  |
|         | 1301         |                             |  |  |  |
|         | 1302         |                             |  |  |  |
|         | 1303         |                             |  |  |  |
| A3      | 1304         | Multi7_LUT3_DFF setting     | [7]:LUT3_15 [7]/DFF19 or LATCH Select<br>0: DFF function, 1: LATCH function<br>[6]:LUT3_15[6]/DFF19 Output Select<br>0: Q output, 1: QB output<br>[5]:LUT3_15 [5]/DFF19<br>0: nRST from Matrix Output, 1: nSET from Matrix Output<br>[4]:LUT3_15 [4]/DFF19 Initial Polarity Select<br>0: Low, 1: High<br>[3:0]:LUT3_15 [3:0] |  |  |
|         | 1305         |                             |  |  |  |
|         | 1306         |                             |  |  |  |
|         | 1307         |                             |  |  |  |
|         | 1308         |                             |  |  |  |
|         | 1309         |                             |  |  |  |
|         | 1310         |                             |  |  |  |
|         | 1311         |                             |  |  |  |
| A4      | 1312         | REG_CNT7_D[7:0]             | Data[7:0]  |  |  |
|         | 1313         |                             |  |  |  |
|         | 1314         |                             |  |  |  |
|         | 1315         |                             |  |  |  |
|         | 1316         |                             |  |  |  |
|         | 1317         |                             |  |  |  |
|         | 1318         |                             |  |  |  |
|         | 1319         |                             |  |  |  |
| A5      | 1320         | CNT0 (16bits) Counted Value | Virtual Input  |  |  |
|         | 1321         |                             |  |  |  |
|         | 1322         |                             |  |  |  |
|         | 1323         |                             |  |  |  |
|         | 1324         |                             |  |  |  |
|         | 1325         |                             |  |  |  |
|         | 1326         |                             |  |  |  |
|         | 1327         |                             |  |  |  |
| A6      | 1328         |                             |  |  |  |
|         | 1329         |                             |  |  |  |
|         | 1330         |                             |  |  |  |
|         | 1331         |                             |  |  |  |
|         | 1332         |                             |  |  |  |
|         | 1333         |                             |  |  |  |
|         | 1334         |                             |  |  |  |
|         | 1335         |                             |  |  |  |

**Auto AEC-Q100 Qualified GreenPAK Programmable Mixed-Signal Matrix**
**Table 57: Register Map (Continued)**

| Address |              | Signal Function            | Register Bit Definition  |
|---------|--------------|----------------------------|--|
| Byte    | Register Bit |                            |  |
| A7      | 1336         | CNT6 (8bits) Counted Value | Virtual Input  |
|         | 1337         |                            |  |
|         | 1338         |                            |  |
|         | 1339         |                            |  |
|         | 1340         |                            |  |
|         | 1341         |                            |  |
|         | 1342         |                            |  |
|         | 1343         |                            |  |
| A8      | 1344         | CNT7 (8bits) Counted Value | Virtual Input  |
|         | 1345         |                            |  |
|         | 1346         |                            |  |
|         | 1347         |                            |  |
|         | 1348         |                            |  |
|         | 1349         |                            |  |
|         | 1350         |                            |  |
|         | 1351         |                            |  |
| A9      | 1352         | LUT3_1_DFF4 setting        | [7]:LUT3_1 [7]/DFF4 or LATCH Select<br>0: DFF function, 1: LATCH function<br>[6]:LUT3_1 [6]/DFF4 Output Select<br>0: Q output, 1: QB output<br>[5]:LUT3_1 [5]/DFF4 Initial Polarity Select<br>0: Low, 1: High<br>[4]:LUT3_1 [4]/DFF4<br>0: nRST from Matrix Output, 1: nSET from Matrix Output<br>[3]:LUT3_1 [3]/DFF4 Active level selection for RST/SET<br>0: Active low level reset/set, 1: Active high level reset/set<br>[2:0]: LUT3_1 [2:0] |
|         | 1353         |                            |  |
|         | 1354         |                            |  |
|         | 1355         |                            |  |
|         | 1356         |                            |  |
|         | 1357         |                            |  |
|         | 1358         |                            |  |
|         | 1359         |                            |  |
| AA      | 1360         | LUT3_2_DFF5 setting        | [7]:LUT3_2 [7]/DFF5 or LATCH Select<br>0: DFF function, 1: LATCH function<br>[6]:LUT3_2 [6]/DFF5 Output Select<br>0: Q output, 1: QB output<br>[5]:LUT3_2 [5]/DFF5 Initial Polarity Select<br>0: Low, 1: High<br>[4]:LUT3_2 [4]/DFF5<br>0: nRST from Matrix Output, 1: nSET from Matrix Output<br>[3]:LUT3_2 [3]/DFF5 Active level selection for RST/SET<br>0: Active low level reset/set, 1: Active high level reset/set<br>[2:0]: LUT3_2 [2:0] |
|         | 1361         |                            |  |
|         | 1362         |                            |  |
|         | 1363         |                            |  |
|         | 1364         |                            |  |
|         | 1365         |                            |  |
|         | 1366         |                            |  |
|         | 1367         |                            |  |
| AB      | 1368         | LUT3_3_DFF6 setting        | [7]:LUT3_3 [7]/DFF6 or LATCH Select<br>0: DFF function, 1: LATCH function<br>[6]:LUT3_3 [6]/DFF6 Output Select<br>0: Q output, 1: QB output<br>[5]:LUT3_3 [5]/DFF6 Initial Polarity Select<br>0: Low, 1: High<br>[4]:LUT3_3 [4]/DFF6<br>0: nRST from Matrix Output, 1: nSET from Matrix Output<br>[3]:LUT3_3 [3]/DFF6 Active level selection for RST/SET<br>0: Active low level reset/set, 1: Active high level reset/set<br>[2:0]: LUT3_3 [2:0] |
|         | 1369         |                            |  |
|         | 1370         |                            |  |
|         | 1371         |                            |  |
|         | 1372         |                            |  |
|         | 1373         |                            |  |
|         | 1374         |                            |  |
|         | 1375         |                            |  |



## SLG46855-A

### Auto AEC-Q100 Qualified GreenPAK Programmable Mixed-Signal Matrix

**Table 57: Register Map (Continued)**

| Address |              | Signal Function         | Register Bit Definition  |  |  |
|---------|--------------|-------------------------|--|--|--|
| Byte    | Register Bit |                         |  |  |  |
| AC      | 1376         | LUT3_4_DFF7 setting     | [7]:LUT3_4 [7]/DFF7 or LATCH Select<br>0: DFF function, 1: LATCH function<br>[6]:LUT3_4 [6]/DFF7 Output Select<br>0: Q output, 1: QB output<br>[5]:LUT3_4 [5]/DFF7 Initial Polarity Select<br>0: Low, 1: High<br>[4]:LUT3_4 [4]/DFF7<br>0: nRST from Matrix Output, 1: nSET from Matrix Output<br>[3]:LUT3_4 [3]/DFF7 Active level selection for RST/SET<br>0: Active low level reset/set, 1: Active high level reset/set<br>[2:0]: LUT3_4 [2:0] |  |  |
|         | 1377         |                         |  |  |  |
|         | 1378         |                         |  |  |  |
|         | 1379         |                         |  |  |  |
|         | 1380         |                         |  |  |  |
|         | 1381         |                         |  |  |  |
|         | 1382         |                         |  |  |  |
|         | 1383         |                         |  |  |  |
| AD      | 1384         | LUT2_3_VAL or PGen_data | LUT2_3[3:0] or PGen 4bit counter data[3:0]   |  |  |
|         | 1385         |                         |  |  |  |
|         | 1386         |                         |  |  |  |
|         | 1387         |                         |  |  |  |
|         | 1388         | LUT3_1 or DFF4 Select   | 0: LUT3_1<br>1: DFF4   |  |  |
|         | 1389         | LUT3_2 or DFF5 Select   | 0: LUT3_2<br>1: DFF5   |  |  |
|         | 1390         | LUT3_3 or DFF6 Select   | 0: LUT3_3<br>1: DFF6   |  |  |
|         | 1391         | LUT3_4 or DFF7 Select   | 0: LUT3_4<br>1: DFF7   |  |  |
| AE      | 1392         | PGen data               | PGen Data[15:0]  |  |  |
|         | 1393         |                         |  |  |  |
|         | 1394         |                         |  |  |  |
|         | 1395         |                         |  |  |  |
|         | 1396         |                         |  |  |  |
|         | 1397         |                         |  |  |  |
|         | 1398         |                         |  |  |  |
|         | 1399         |                         |  |  |  |
| AF      | 1400         |                         |  |  |  |
|         | 1401         |                         |  |  |  |
|         | 1402         |                         |  |  |  |
|         | 1403         |                         |  |  |  |
|         | 1404         |                         |  |  |  |
|         | 1405         |                         |  |  |  |
|         | 1406         |                         |  |  |  |
|         | 1407         |                         |  |  |  |

**Auto AEC-Q100 Qualified GreenPAK Programmable Mixed-Signal Matrix**
**Table 57: Register Map (Continued)**

| Address |              | Signal Function   | Register Bit Definition   |
|---------|--------------|---|---|
| Byte    | Register Bit |   |   |
| B0      | 1408         | LUT2_3 or PGen Select   | 0: LUT2_3<br>1: PGen  |
|         | 1409         | Active level selection for RST/SET for LUT2_3 or PGen                 | 0: Active low level reset/set<br>1: Active high level reset/set   |
|         | 1410         | Active level selection for RST/SET for LUT3_16 or Pipe Delay/RIPP CNT | 0: Active low level reset/set<br>1: Active high level reset/set   |
|         | 1411         | Out of LUT3_16 or Out0 of Pipe Delay/RIPP CNT Select                  | 0: LUT3_16<br>1: OUT0 of Pipe Delay or RIPP CNT   |
|         | 1412         | PIPE_RIPP_CNT_S   | 0: Pipe delay mode selection<br>1: Ripple Counter mode selection  |
|         | 1413         | Pipe Delay OUT1 Polarity Select                                       | 0: Non-inverted<br>1: Inverted  |
|         | 1414         | LUT4_0 or DFF12 Select  | 0: LUT4_0<br>1: DFF12   |
|         | 1415         | LUT3_0 or DFF3 Select   | 0: LUT3_0<br>1: DFF3  |
| B1      | 1416         | LUT value or pipe delay out sel or nSET/END value                     | [7:4]: LUT3_8 [7:4]/REG_S1[3:0] pipe delay out1 sel<br>[3:0]: LUT3_8 [3:0]/REG_S0[3:0] pipe delay out0 sel<br>at RIPP CNT mode:<br>bit[1418:1416] is the nSET value<br>bit[1421:1419] is the END value<br>bit[1422] is the range control: 0 full cycle, 1 range cycle<br>bit[1423] Not used   |
|         | 1417         |   |   |
|         | 1418         |   |   |
|         | 1419         |   |   |
|         | 1420         |   |   |
|         | 1421         |   |   |
|         | 1422         |   |   |
|         | 1423         |   |   |
| B2      | 1424         | LUT4_0_DFF12 setting  | [15]:LUT4_0 [15]/DFF12 or LATCH Select<br>0: DFF function, 1: LATCH function<br>[14]:LUT4_0 [14]/DFF12 Output Select<br>0: Q output, 1: QB output<br>[13]:LUT4_0 [13]/DFF12 Initial Polarity Select<br>0: Low, 1: High<br>[12]:LUT4_0 [12]/DFF12 stage selection<br>0: Q of first DFF; 1 Q of second DFF<br>[11]:LUT4_0 [11]/DFF12<br>0: nRST from Matrix Output, 1: nSET from Matrix Output<br>[10]:LUT4_0 [10]/DFF12 Active level selection for RST/SET<br>0: Active low level reset/set, 1: Active high level reset/set<br>[9:0]: LUT4_0 [9:0] |
|         | 1425         |   |   |
|         | 1426         |   |   |
|         | 1427         |   |   |
|         | 1428         |   |   |
|         | 1429         |   |   |
|         | 1430         |   |   |
|         | 1431         |   |   |
| B3      | 1432         | LUT3_0_DFF3 setting   | [7]:LUT3_0 [7]/DFF3 or LATCH Select<br>0: DFF function, 1: LATCH function<br>[6]:LUT3_0 [6]/DFF3 Output Select<br>0: Q output, 1: QB output<br>[5]:LUT3_0 [5]/DFF3 Initial Polarity Select<br>0: Low, 1: High<br>[4]:LUT3_0 [4]/DFF3stage selection<br>0: Q of first DFF; 1 Q of second DFF<br>[3]:LUT3_0 [3]/DFF3<br>0: nRST from Matrix Output, 1: nSET from Matrix Output<br>[2]:LUT3_0 [2]/DFF3 Active level selection for RST/SET<br>0: Active low level reset/set, 1: Active high level reset/set<br>[1:0]: LUT3_0 [1:0]                    |
|         | 1433         |   |   |
|         | 1434         |   |   |
|         | 1435         |   |   |
|         | 1436         |   |   |
|         | 1437         |   |   |
|         | 1438         |   |   |
|         | 1439         |   |   |
| B4      | 1440         | LUT3_0_DFF3 setting   | [7]:LUT3_0 [7]/DFF3 or LATCH Select<br>0: DFF function, 1: LATCH function<br>[6]:LUT3_0 [6]/DFF3 Output Select<br>0: Q output, 1: QB output<br>[5]:LUT3_0 [5]/DFF3 Initial Polarity Select<br>0: Low, 1: High<br>[4]:LUT3_0 [4]/DFF3stage selection<br>0: Q of first DFF; 1 Q of second DFF<br>[3]:LUT3_0 [3]/DFF3<br>0: nRST from Matrix Output, 1: nSET from Matrix Output<br>[2]:LUT3_0 [2]/DFF3 Active level selection for RST/SET<br>0: Active low level reset/set, 1: Active high level reset/set<br>[1:0]: LUT3_0 [1:0]                    |
|         | 1441         |   |   |
|         | 1442         |   |   |
|         | 1443         |   |   |
|         | 1444         |   |   |
|         | 1445         |   |   |
|         | 1446         |   |   |
|         | 1447         |   |   |

**Auto AEC-Q100 Qualified GreenPAK Programmable Mixed-Signal Matrix**
**Table 57: Register Map (Continued)**

| Address |  | Signal Function  | Register Bit Definition  |
|---------|--|--|--|
| Byte    | Register Bit   |  |  |
| B5      | 1448   | Filter or Edge Detector selection  | 0, filter<br>1, edge det   |
|         | 1449   | Output Polarity Select   | 0: output non-invert<br>1: output invert   |
|         | 1450   | Select the edge mode   | 00: Rising Edge Det<br>01: Falling Edge Det<br>10: Both Edge Det<br>11: Both Edge DLY                                    |
|         | 1451   |  |  |
|         | 1452   | Delay Value Select for Programmable Delay & Edge Detector  | 00: 125 ns<br>01: 250 ns<br>10: 375 ns<br>11: 500 ns   |
|         | 1453   |  |  |
|         | 1454   |  |  |
| 1455    | Select the Edge Mode of Programmable Delay & Edge Detector | 00: Rising Edge Detector<br>01: Falling Edge Detector<br>10: Both Edge Detector<br>11: Both Edge Delay |  |
| B6      | 1456   | LUT3_5_DFF8 setting  | [7]:LUT3_5 [7]/DFF8 or LATCH Select<br>0: DFF function, 1: LATCH function  |
|         | 1457   |  | [6]:LUT3_5 [6]/DFF8 Output Select<br>0: Q output, 1: QB output   |
|         | 1458   |  | [5]:LUT3_5 [5]/DFF8 Initial Polarity Select<br>0: Low, 1: High   |
|         | 1459   |  | [4]:LUT3_5 [4]/DFF8<br>0: nRST from Matrix Output, 1: nSET from Matrix Output  |
|         | 1460   |  | [3]:LUT3_5 [3]/DFF8 Active level selection for RST/SET<br>0: Active low level reset/set, 1: Active high level reset/set  |
|         | 1461   |  | [2:0]: LUT3_5 [2:0]  |
|         | 1462   |  |  |
| B7      | 1464   | LUT3_6_DFF9 setting  | [7]:LUT3_6 [7]/DFF9 or LATCH Select<br>0: DFF function, 1: LATCH function  |
|         | 1465   |  | [6]:LUT3_6 [6]/DFF9 Output Select<br>0: Q output, 1: QB output   |
|         | 1466   |  | [5]:LUT3_6 [5]/DFF9 Initial Polarity Select<br>0: Low, 1: High   |
|         | 1467   |  | [4]:LUT3_6 [4]/DFF9<br>0: nRST from Matrix Output, 1: nSET from Matrix Output  |
|         | 1468   |  | [3]:LUT3_6 [3]/DFF9 Active level selection for RST/SET<br>0: Active low level reset/set, 1: Active high level reset/set  |
|         | 1469   |  | [2:0]: LUT3_6 [2:0]  |
|         | 1470   |  |  |
| B8      | 1472   | LUT3_7_DFF10 setting   | [7]:LUT3_7 [7]/DFF10 or LATCH Select<br>0: DFF function, 1: LATCH function   |
|         | 1473   |  | [6]:LUT3_7 [6]/DFF10 Output Select<br>0: Q output, 1: QB output  |
|         | 1474   |  | [5]:LUT3_7 [5]/DFF10 Initial Polarity Select<br>0: Low, 1: High  |
|         | 1475   |  | [4]:LUT3_7 [4]/DFF10<br>0: nRST from Matrix Output, 1: nSET from Matrix Output   |
|         | 1476   |  | [3]:LUT3_7 [3]/DFF10 Active level selection for RST/SET<br>0: Active low level reset/set, 1: Active high level reset/set |
|         | 1477   |  | [2:0]: LUT3_7 [2:0]  |
|         | 1478   |  |  |
| B9      | 1480   | LUT3_8_DFF11 setting   | [7]:LUT3_8 [7]/DFF11 or LATCH Select<br>0: DFF function, 1: LATCH function   |
|         | 1481   |  | [6]:LUT3_8 [6]/DFF11 Output Select<br>0: Q output, 1: QB output  |
|         | 1482   |  | [5]:LUT3_8 [5]/DFF11 Initial Polarity Select<br>0: Low, 1: High  |
|         | 1483   |  | [4]:LUT3_8 [4]/DFF11<br>0: nRST from Matrix Output, 1: nSET from Matrix Output   |
|         | 1484   |  | [3]:LUT3_8 [3]/DFF11 Active level selection for RST/SET<br>0: Active low level reset/set, 1: Active high level reset/set |
|         | 1485   |  | [2:0]: LUT3_8 [2:0]  |
|         | 1486   |  |  |
| 1487    |  |  |  |

# SLG46855-A

## Auto AEC-Q100 Qualified GreenPAK Programmable Mixed-Signal Matrix

**Table 57: Register Map (Continued)**

| Address |              | Signal Function        | Register Bit Definition   |
|---------|--------------|------------------------|---|
| Byte    | Register Bit |                        |   |
| BA      | 1488         | LUT2_0 or DFF0 Select  | 0: LUT2_0<br>1: DFF0  |
|         | 1489         | LUT2_1 or DFF1 Select  | 0: LUT2_1<br>1: DFF1  |
|         | 1490         | LUT2_2 or DFF2 Select  | 0: LUT2_2<br>1: DFF2  |
|         | 1491         | Reserved               |   |
|         | 1492         | LUT3_5 or DFF8 Select  | 0: LUT3_5<br>1: DFF8  |
|         | 1493         | LUT3_6 or DFF9 Select  | 0: LUT3_6<br>1: DFF9  |
|         | 1494         | LUT3_7 or DFF10 Select | 0: LUT3_7<br>1: DFF10   |
|         | 1495         | LUT3_8 or DFF11 Select | 0: LUT3_8<br>1: DFF11   |
| BB      | 1496         | LUT2_0/DFF0 setting    | [3]:LUT2_0 [3]/DFF0 or LATCH Select<br>0: DFF function, 1: LATCH function |
|         | 1497         |                        | [2]:LUT2_0 [2]/DFF0 Output Select<br>0: Q output, 1: QB output            |
|         | 1498         |                        | [1]:LUT2_0 [1]/DFF0 Initial Polarity Select<br>0: Low, 1: High            |
|         | 1499         |                        | [0]:LUT2_0 [0]  |
|         | 1500         | LUT2_1/DFF1 setting    | [3]:LUT2_1 [3]/DFF1 or LATCH Select<br>0: DFF function, 1: LATCH function |
|         | 1501         |                        | [2]:LUT2_1 [2]/DFF1 Output Select<br>0: Q output, 1: QB output            |
|         | 1502         |                        | [1]:LUT2_1 [1]/DFF1 Initial Polarity Select<br>0: Low, 1: High            |
|         | 1503         |                        | [0]:LUT2_1 [0]  |
| BC      | 1504         | LUT2_2/DFF2 setting    | [3]:LUT2_2 [3]/DFF2 or LATCH Select<br>0: DFF function, 1: LATCH function |
|         | 1505         |                        | [2]:LUT2_2 [2]/DFF2 Output Select<br>0: Q output, 1: QB output            |
|         | 1506         |                        | [1]:LUT2_2 [1]/DFF2 Initial Polarity Select<br>0: Low, 1: High            |
|         | 1507         |                        | [0]:LUT2_2 [0]  |
|         | 1508         | Reserved               |   |
|         | 1509         |                        |   |
|         | 1510         |                        |   |
|         | 1511         |                        |   |
| BD      | 1512         | Reserved               |   |
|         | 1513         |                        |   |
|         | 1514         |                        |   |
|         | 1515         |                        |   |
|         | 1516         |                        |   |
|         | 1517         |                        |   |
|         | 1518         |                        |   |
|         | 1519         |                        |   |

# SLG46855-A

## Auto AEC-Q100 Qualified GreenPAK Programmable Mixed-Signal Matrix

**Table 57: Register Map (Continued)**

| Address |              | Signal Function | Register Bit Definition |
|---------|--------------|-----------------|-------------------------|
| Byte    | Register Bit |                 |                         |
| BE      | 1520         | Reserved        |                         |
|         | 1521         | Reserved        |                         |
|         | 1522         | Reserved        |                         |
|         | 1523         | Reserved        |                         |
|         | 1524         | Reserved        |                         |
|         | 1525         |                 |                         |
|         | 1526         |                 |                         |
|         | 1527         |                 |                         |
| BF      | 1528         | Reserved        |                         |
|         | 1529         | Reserved        |                         |
|         | 1530         | Reserved        |                         |
|         | 1531         | Reserved        |                         |
|         | 1532         | Reserved        |                         |
|         | 1533         | Reserved        |                         |
|         | 1534         | Reserved        |                         |
|         | 1535         | Reserved        |                         |
| C0      | 1536         | Reserved        |                         |
|         | 1537         | Reserved        |                         |
|         | 1538         | Reserved        |                         |
|         | 1539         | Reserved        |                         |
|         | 1540         | Reserved        |                         |
|         | 1541         | Reserved        |                         |
|         | 1542         | Reserved        |                         |
|         | 1543         | Reserved        |                         |
| C1      | 1544         | Reserved        |                         |
|         | 1545         | Reserved        |                         |
|         | 1546         | Reserved        |                         |
|         | 1547         | Reserved        |                         |
|         | 1548         | Reserved        |                         |
|         | 1549         | Reserved        |                         |
|         | 1550         | Reserved        |                         |
|         | 1551         | Reserved        |                         |
| C2      | 1552         | Reserved        |                         |
|         | 1553         | Reserved        |                         |
|         | 1554         | Reserved        |                         |
|         | 1555         | Reserved        |                         |
|         | 1556         | Reserved        |                         |
|         | 1557         | Reserved        |                         |
|         | 1558         | Reserved        |                         |
|         | 1559         | Reserved        |                         |
| C3      | 1560         | Reserved        |                         |
|         | 1561         | Reserved        |                         |
|         | 1562         | Reserved        |                         |
|         | 1563         | Reserved        |                         |
|         | 1564         | Reserved        |                         |
|         | 1565         | Reserved        |                         |
|         | 1566         | Reserved        |                         |
|         | 1567         | Reserved        |                         |

# SLG46855-A

## Auto AEC-Q100 Qualified GreenPAK Programmable Mixed-Signal Matrix

**Table 57: Register Map (Continued)**

| Address |              | Signal Function | Register Bit Definition |
|---------|--------------|-----------------|-------------------------|
| Byte    | Register Bit |                 |                         |
| C4      | 1568         | Reserved        |                         |
|         | 1569         | Reserved        |                         |
|         | 1570         | Reserved        |                         |
|         | 1571         | Reserved        |                         |
|         | 1572         | Reserved        |                         |
|         | 1573         | Reserved        |                         |
|         | 1574         | Reserved        |                         |
|         | 1575         | Reserved        |                         |
| C5      | 1576         | Reserved        |                         |
|         | 1577         | Reserved        |                         |
|         | 1578         | Reserved        |                         |
|         | 1579         | Reserved        |                         |
|         | 1580         | Reserved        |                         |
|         | 1581         | Reserved        |                         |
|         | 1582         | Reserved        |                         |
|         | 1583         | Reserved        |                         |
| C6      | 1584         | Reserved        |                         |
|         | 1585         | Reserved        |                         |
|         | 1586         | Reserved        |                         |
|         | 1587         | Reserved        |                         |
|         | 1588         | Reserved        |                         |
|         | 1589         | Reserved        |                         |
|         | 1590         | Reserved        |                         |
|         | 1591         | Reserved        |                         |
| C7      | 1592         | Reserved        |                         |
|         | 1593         | Reserved        |                         |
|         | 1594         | Reserved        |                         |
|         | 1595         | Reserved        |                         |
|         | 1596         | Reserved        |                         |
|         | 1597         | Reserved        |                         |
|         | 1598         | Reserved        |                         |
|         | 1599         | Reserved        |                         |
| C8      | 1600         | Reserved        |                         |
|         | 1601         | Reserved        |                         |
|         | 1602         | Reserved        |                         |
|         | 1603         | Reserved        |                         |
|         | 1604         | Reserved        |                         |
|         | 1605         | Reserved        |                         |
|         | 1606         | Reserved        |                         |
|         | 1607         | Reserved        |                         |
| C9      | 1608         | Reserved        |                         |
|         | 1609         | Reserved        |                         |
|         | 1610         | Reserved        |                         |
|         | 1611         | Reserved        |                         |
|         | 1612         | Reserved        |                         |
|         | 1613         | Reserved        |                         |
|         | 1614         | Reserved        |                         |
|         | 1615         | Reserved        |                         |

# SLG46855-A

## Auto AEC-Q100 Qualified GreenPAK Programmable Mixed-Signal Matrix

**Table 57: Register Map (Continued)**

| Address |              | Signal Function | Register Bit Definition |
|---------|--------------|-----------------|-------------------------|
| Byte    | Register Bit |                 |                         |
| CA      | 1616         | Reserved        |                         |
|         | 1617         | Reserved        |                         |
|         | 1618         | Reserved        |                         |
|         | 1619         | Reserved        |                         |
|         | 1620         | Reserved        |                         |
|         | 1621         | Reserved        |                         |
|         | 1622         | Reserved        |                         |
| CB      | 1623         | Reserved        |                         |
|         | 1624         | Reserved        |                         |
|         | 1625         | Reserved        |                         |
|         | 1626         | Reserved        |                         |
|         | 1627         | Reserved        |                         |
|         | 1628         | Reserved        |                         |
|         | 1629         | Reserved        |                         |
| CC      | 1630         | Reserved        |                         |
|         | 1631         | Reserved        |                         |
|         | 1632         | Reserved        |                         |
|         | 1633         | Reserved        |                         |
|         | 1634         | Reserved        |                         |
|         | 1635         | Reserved        |                         |
|         | 1636         | Reserved        |                         |
| CD      | 1637         | Reserved        |                         |
|         | 1638         | Reserved        |                         |
|         | 1639         | Reserved        |                         |
|         | 1640         | Reserved        |                         |
|         | 1641         | Reserved        |                         |
|         | 1642         | Reserved        |                         |
|         | 1643         | Reserved        |                         |
| CE      | 1644         | Reserved        |                         |
|         | 1645         | Reserved        |                         |
|         | 1646         | Reserved        |                         |
|         | 1647         | Reserved        |                         |
|         | 1648         | Reserved        |                         |
|         | 1649         | Reserved        |                         |
|         | 1650         | Reserved        |                         |
| CF      | 1651         | Reserved        |                         |
|         | 1652         | Reserved        |                         |
|         | 1653         | Reserved        |                         |
|         | 1654         | Reserved        |                         |
|         | 1655         | Reserved        |                         |
|         | 1656         | Reserved        |                         |
|         | 1657         | Reserved        |                         |
| CF      | 1658         | Reserved        |                         |
|         | 1659         | Reserved        |                         |
|         | 1660         | Reserved        |                         |
|         | 1661         | Reserved        |                         |
|         | 1662         | Reserved        |                         |
|         | 1663         | Reserved        |                         |

# SLG46855-A

## Auto AEC-Q100 Qualified GreenPAK Programmable Mixed-Signal Matrix

**Table 57: Register Map (Continued)**

| Address |              | Signal Function | Register Bit Definition |
|---------|--------------|-----------------|-------------------------|
| Byte    | Register Bit |                 |                         |
| D0      | 1664         | Reserved        |                         |
|         | 1665         | Reserved        |                         |
|         | 1666         | Reserved        |                         |
|         | 1667         | Reserved        |                         |
|         | 1668         | Reserved        |                         |
|         | 1669         | Reserved        |                         |
|         | 1670         | Reserved        |                         |
|         | 1671         | Reserved        |                         |
| D1      | 1672         | Reserved        |                         |
|         | 1673         | Reserved        |                         |
|         | 1674         | Reserved        |                         |
|         | 1675         | Reserved        |                         |
|         | 1676         | Reserved        |                         |
|         | 1677         | Reserved        |                         |
|         | 1678         | Reserved        |                         |
|         | 1679         | Reserved        |                         |
| D2      | 1680         | Reserved        |                         |
|         | 1681         | Reserved        |                         |
|         | 1682         | Reserved        |                         |
|         | 1683         | Reserved        |                         |
|         | 1684         | Reserved        |                         |
|         | 1685         | Reserved        |                         |
|         | 1686         | Reserved        |                         |
|         | 1687         | Reserved        |                         |
| D3      | 1688         | Reserved        |                         |
|         | 1689         | Reserved        |                         |
|         | 1690         | Reserved        |                         |
|         | 1691         | Reserved        |                         |
|         | 1692         | Reserved        |                         |
|         | 1693         | Reserved        |                         |
|         | 1694         | Reserved        |                         |
|         | 1695         | Reserved        |                         |
| D4      | 1696         | Reserved        |                         |
|         | 1697         | Reserved        |                         |
|         | 1698         | Reserved        |                         |
|         | 1699         | Reserved        |                         |
|         | 1700         | Reserved        |                         |
|         | 1701         | Reserved        |                         |
|         | 1702         | Reserved        |                         |
|         | 1703         | Reserved        |                         |
| D5      | 1704         | Reserved        |                         |
|         | 1705         | Reserved        |                         |
|         | 1706         | Reserved        |                         |
|         | 1707         | Reserved        |                         |
|         | 1708         | Reserved        |                         |
|         | 1709         | Reserved        |                         |
|         | 1710         | Reserved        |                         |
|         | 1711         | Reserved        |                         |



# SLG46855-A

## Auto AEC-Q100 Qualified GreenPAK Programmable Mixed-Signal Matrix

**Table 57: Register Map (Continued)**

| Address |              | Signal Function | Register Bit Definition |
|---------|--------------|-----------------|-------------------------|
| Byte    | Register Bit |                 |                         |
| D6      | 1712         | Reserved        |                         |
|         | 1713         | Reserved        |                         |
|         | 1714         | Reserved        |                         |
|         | 1715         | Reserved        |                         |
|         | 1716         | Reserved        |                         |
|         | 1717         | Reserved        |                         |
|         | 1718         | Reserved        |                         |
|         | 1719         | Reserved        |                         |
| D7      | 1720         | Reserved        |                         |
|         | 1721         | Reserved        |                         |
|         | 1722         | Reserved        |                         |
|         | 1723         | Reserved        |                         |
|         | 1724         | Reserved        |                         |
|         | 1725         | Reserved        |                         |
|         | 1726         | Reserved        |                         |
|         | 1727         | Reserved        |                         |
| D8      | 1728         | Reserved        |                         |
|         | 1729         | Reserved        |                         |
|         | 1730         | Reserved        |                         |
|         | 1731         | Reserved        |                         |
|         | 1732         | Reserved        |                         |
|         | 1733         | Reserved        |                         |
|         | 1734         | Reserved        |                         |
|         | 1735         | Reserved        |                         |
| D9      | 1736         | Reserved        |                         |
|         | 1737         | Reserved        |                         |
|         | 1738         | Reserved        |                         |
|         | 1739         | Reserved        |                         |
|         | 1740         | Reserved        |                         |
|         | 1741         | Reserved        |                         |
|         | 1742         | Reserved        |                         |
|         | 1743         | Reserved        |                         |
| DA      | 1744         | Reserved        |                         |
|         | 1745         | Reserved        |                         |
|         | 1746         | Reserved        |                         |
|         | 1747         | Reserved        |                         |
|         | 1748         | Reserved        |                         |
|         | 1749         | Reserved        |                         |
|         | 1750         | Reserved        |                         |
|         | 1751         | Reserved        |                         |
| DB      | 1752         | Reserved        |                         |
|         | 1753         | Reserved        |                         |
|         | 1754         | Reserved        |                         |
|         | 1755         | Reserved        |                         |
|         | 1756         | Reserved        |                         |
|         | 1757         | Reserved        |                         |
|         | 1758         | Reserved        |                         |
|         | 1759         | Reserved        |                         |

# SLG46855-A

## Auto AEC-Q100 Qualified GreenPAK Programmable Mixed-Signal Matrix

**Table 57: Register Map (Continued)**

| Address |              | Signal Function | Register Bit Definition |
|---------|--------------|-----------------|-------------------------|
| Byte    | Register Bit |                 |                         |
| DC      | 1760         | Reserved        |                         |
|         | 1761         | Reserved        |                         |
|         | 1762         | Reserved        |                         |
|         | 1763         | Reserved        |                         |
|         | 1764         | Reserved        |                         |
|         | 1765         | Reserved        |                         |
|         | 1766         | Reserved        |                         |
|         | 1767         | Reserved        |                         |
| DD      | 1768         | Reserved        |                         |
|         | 1769         | Reserved        |                         |
|         | 1770         | Reserved        |                         |
|         | 1771         | Reserved        |                         |
|         | 1772         | Reserved        |                         |
|         | 1773         | Reserved        |                         |
|         | 1774         | Reserved        |                         |
|         | 1775         | Reserved        |                         |
| DE      | 1776         | Reserved        |                         |
|         | 1777         | Reserved        |                         |
|         | 1778         | Reserved        |                         |
|         | 1779         | Reserved        |                         |
|         | 1780         | Reserved        |                         |
|         | 1781         | Reserved        |                         |
|         | 1782         | Reserved        |                         |
|         | 1783         | Reserved        |                         |
| DF      | 1784         | Reserved        |                         |
|         | 1785         | Reserved        |                         |
|         | 1786         | Reserved        |                         |
|         | 1787         | Reserved        |                         |
|         | 1788         | Reserved        |                         |
|         | 1789         | Reserved        |                         |
|         | 1790         | Reserved        |                         |
|         | 1791         | Reserved        |                         |
| E0      | 1792         | Reserved        |                         |
|         | 1793         | Reserved        |                         |
|         | 1794         | Reserved        |                         |
|         | 1795         | Reserved        |                         |
|         | 1796         | Reserved        |                         |
|         | 1797         | Reserved        |                         |
|         | 1798         | Reserved        |                         |
|         | 1799         | Reserved        |                         |
| E1      | 1800         | Reserved        |                         |
|         | 1801         | Reserved        |                         |
|         | 1802         | Reserved        |                         |
|         | 1803         | Reserved        |                         |
|         | 1804         | Reserved        |                         |
|         | 1805         | Reserved        |                         |
|         | 1806         | Reserved        |                         |
|         | 1807         | Reserved        |                         |

# SLG46855-A

## Auto AEC-Q100 Qualified GreenPAK Programmable Mixed-Signal Matrix

**Table 57: Register Map (Continued)**

| Address |              | Signal Function | Register Bit Definition |
|---------|--------------|-----------------|-------------------------|
| Byte    | Register Bit |                 |                         |
| E2      | 1808         | Reserved        |                         |
|         | 1809         | Reserved        |                         |
|         | 1810         | Reserved        |                         |
|         | 1811         | Reserved        |                         |
|         | 1812         | Reserved        |                         |
|         | 1813         | Reserved        |                         |
|         | 1814         | Reserved        |                         |
|         | 1815         | Reserved        |                         |
| E3      | 1816         | Reserved        |                         |
|         | 1817         | Reserved        |                         |
|         | 1818         | Reserved        |                         |
|         | 1819         | Reserved        |                         |
|         | 1820         | Reserved        |                         |
|         | 1821         | Reserved        |                         |
|         | 1822         | Reserved        |                         |
|         | 1823         | Reserved        |                         |
| E4      | 1824         | Reserved        |                         |
|         | 1825         | Reserved        |                         |
|         | 1826         | Reserved        |                         |
|         | 1827         | Reserved        |                         |
|         | 1828         | Reserved        |                         |
|         | 1829         | Reserved        |                         |
|         | 1830         | Reserved        |                         |
|         | 1831         | Reserved        |                         |
| E5      | 1832         | Reserved        |                         |
|         | 1833         | Reserved        |                         |
|         | 1834         | Reserved        |                         |
|         | 1835         | Reserved        |                         |
|         | 1836         | Reserved        |                         |
|         | 1837         | Reserved        |                         |
|         | 1838         | Reserved        |                         |
|         | 1839         | Reserved        |                         |
| E6      | 1840         | Reserved        |                         |
|         | 1841         | Reserved        |                         |
|         | 1842         | Reserved        |                         |
|         | 1843         | Reserved        |                         |
|         | 1844         | Reserved        |                         |
|         | 1845         | Reserved        |                         |
|         | 1846         | Reserved        |                         |
|         | 1847         | Reserved        |                         |
| E7      | 1848         | Reserved        |                         |
|         | 1849         | Reserved        |                         |
|         | 1850         | Reserved        |                         |
|         | 1851         | Reserved        |                         |
|         | 1852         | Reserved        |                         |
|         | 1853         | Reserved        |                         |
|         | 1854         | Reserved        |                         |
|         | 1855         | Reserved        |                         |

# SLG46855-A

## Auto AEC-Q100 Qualified GreenPAK Programmable Mixed-Signal Matrix

**Table 57: Register Map (Continued)**

| Address |              | Signal Function | Register Bit Definition |
|---------|--------------|-----------------|-------------------------|
| Byte    | Register Bit |                 |                         |
| E8      | 1856         | Reserved        |                         |
|         | 1857         | Reserved        |                         |
|         | 1858         | Reserved        |                         |
|         | 1859         | Reserved        |                         |
|         | 1860         | Reserved        |                         |
|         | 1861         | Reserved        |                         |
|         | 1862         | Reserved        |                         |
|         | 1863         | Reserved        |                         |
| E9      | 1864         | Reserved        |                         |
|         | 1865         | Reserved        |                         |
|         | 1866         | Reserved        |                         |
|         | 1867         | Reserved        |                         |
|         | 1868         | Reserved        |                         |
|         | 1869         | Reserved        |                         |
|         | 1870         | Reserved        |                         |
|         | 1871         | Reserved        |                         |
| EA      | 1872         | Reserved        |                         |
|         | 1873         | Reserved        |                         |
|         | 1874         | Reserved        |                         |
|         | 1875         | Reserved        |                         |
|         | 1876         | Reserved        |                         |
|         | 1877         | Reserved        |                         |
|         | 1878         | Reserved        |                         |
|         | 1879         | Reserved        |                         |
| EB      | 1880         | Reserved        |                         |
|         | 1881         | Reserved        |                         |
|         | 1882         | Reserved        |                         |
|         | 1883         | Reserved        |                         |
|         | 1884         | Reserved        |                         |
|         | 1885         | Reserved        |                         |
|         | 1886         | Reserved        |                         |
|         | 1887         | Reserved        |                         |
| EC      | 1888         | Reserved        |                         |
|         | 1889         | Reserved        |                         |
|         | 1890         | Reserved        |                         |
|         | 1891         | Reserved        |                         |
|         | 1892         | Reserved        |                         |
|         | 1893         | Reserved        |                         |
|         | 1894         | Reserved        |                         |
|         | 1895         | Reserved        |                         |
| ED      | 1896         | Reserved        |                         |
|         | 1897         | Reserved        |                         |
|         | 1898         | Reserved        |                         |
|         | 1899         | Reserved        |                         |
|         | 1900         | Reserved        |                         |
|         | 1901         | Reserved        |                         |
|         | 1902         | Reserved        |                         |
|         | 1903         | Reserved        |                         |

# SLG46855-A

## Auto AEC-Q100 Qualified GreenPAK Programmable Mixed-Signal Matrix

**Table 57: Register Map (Continued)**

| Address |              | Signal Function | Register Bit Definition |
|---------|--------------|-----------------|-------------------------|
| Byte    | Register Bit |                 |                         |
| EE      | 1904         | Reserved        |                         |
|         | 1905         | Reserved        |                         |
|         | 1906         | Reserved        |                         |
|         | 1907         | Reserved        |                         |
|         | 1908         | Reserved        |                         |
|         | 1909         | Reserved        |                         |
|         | 1910         | Reserved        |                         |
|         | 1911         | Reserved        |                         |
| EF      | 1912         | Reserved        |                         |
|         | 1913         | Reserved        |                         |
|         | 1914         | Reserved        |                         |
|         | 1915         | Reserved        |                         |
|         | 1916         | Reserved        |                         |
|         | 1917         | Reserved        |                         |
|         | 1918         | Reserved        |                         |
|         | 1919         | Reserved        |                         |
| F0      | 1920         | Reserved        |                         |
|         | 1921         | Reserved        |                         |
|         | 1922         | Reserved        |                         |
|         | 1923         | Reserved        |                         |
|         | 1924         | Reserved        |                         |
|         | 1925         | Reserved        |                         |
|         | 1926         | Reserved        |                         |
|         | 1927         | Reserved        |                         |
| F1      | 1928         | Reserved        |                         |
|         | 1929         | Reserved        |                         |
|         | 1930         | Reserved        |                         |
|         | 1931         | Reserved        |                         |
|         | 1932         | Reserved        |                         |
|         | 1933         | Reserved        |                         |
|         | 1934         | Reserved        |                         |
|         | 1935         | Reserved        |                         |
| F2      | 1936         | Reserved        |                         |
|         | 1937         | Reserved        |                         |
|         | 1938         | Reserved        |                         |
|         | 1939         | Reserved        |                         |
|         | 1940         | Reserved        |                         |
|         | 1941         | Reserved        |                         |
|         | 1942         | Reserved        |                         |
|         | 1943         | Reserved        |                         |
| F3      | 1944         | Reserved        |                         |
|         | 1945         | Reserved        |                         |
|         | 1946         | Reserved        |                         |
|         | 1947         | Reserved        |                         |
|         | 1948         | Reserved        |                         |
|         | 1949         | Reserved        |                         |
|         | 1950         | Reserved        |                         |
|         | 1951         | Reserved        |                         |

# SLG46855-A

## Auto AEC-Q100 Qualified GreenPAK Programmable Mixed-Signal Matrix

**Table 57: Register Map (Continued)**

| Address |              | Signal Function  | Register Bit Definition  |
|---------|--------------|--|--|
| Byte    | Register Bit |  |  |
| F4      | 1952         | GPO0 I2C output expander data                                    |  |
|         | 1953         | GPO0 I2C output expander select                                  | 0: GPO0 output come from matrix<br>1: GPO0 output is register  |
|         | 1954         | GPIO6 I2C output expander data                                   |  |
|         | 1955         | GPIO6 I2C output expander select                                 | 0: GPIO6 output come from matrix<br>1: GPIO6 output is register  |
|         | 1956         | GPIO7 I2C output expander data                                   |  |
|         | 1957         | GPIO7 I2C output expander select                                 | 0: GPIO7 output come from matrix<br>1: GPIO7 output is register  |
|         | 1958         | GPIO8 I2C output expander data                                   |  |
|         | 1959         | GPIO8 I2C output expander select                                 | 0: GPIO8 output come from matrix<br>1: GPIO8 output is register  |
| F5      | 1960         | I2C reset bit with reloading NVM into Data register (soft reset) | 0: Keep existing condition<br>1: Reset execution   |
|         | 1961         | IO Latching Enable During I2C Write Interface                    | 0: Disable<br>1: Enable  |
|         | 1962         | Reserved   |  |
|         | 1963         | Protect mode enable  | 0: Disable<br>1: Enable  |
|         | 1964         | Reserved   |  |
|         | 1965         | Register protection mode bit 0                                   | 000: all open read/write (mode 0);<br>001: partly lock read (mode 1);<br>010: partly lock read2 (mode 2);<br>011: partly lock read2/write (mode 3);<br>100: all lock read (mode 4);<br>101: all lock write (mode 5);<br>110: all lock read/write (mode 6). |
|         | 1966         | Register protection mode bit 1                                   |  |
|         | 1967         | Register protection mode bit 2                                   |  |
| F6      | 1968         | I <sup>2</sup> C write mask bits                                 | 1: mask<br>0: overwrite  |
|         | 1969         |  |  |
|         | 1970         |  |  |
|         | 1971         |  |  |
|         | 1972         |  |  |
|         | 1973         |  |  |
|         | 1974         |  |  |
|         | 1975         |  |  |
| F7      | 1976         | Reserved   |  |
|         | 1977         |  |  |
|         | 1978         |  |  |
|         | 1979         |  |  |
|         | 1980         |  |  |
|         | 1981         |  |  |
|         | 1982         |  |  |
|         | 1983         |  |  |
| F8      | 1984         | Reserved   |  |
|         | 1985         |  |  |
|         | 1986         |  |  |
|         | 1987         |  |  |
|         | 1988         |  |  |
|         | 1989         |  |  |
|         | 1990         |  |  |
|         | 1991         |  |  |

**Auto AEC-Q100 Qualified GreenPAK Programmable Mixed-Signal Matrix**
**Table 57: Register Map (Continued)**

| Address |                              | Signal Function                          | Register Bit Definition                  |
|---------|------------------------------|--|--|
| Byte    | Register Bit                 |  |  |
| F9      | 1992                         | Reserved                                 |  |
|         | 1993                         | Reserved                                 |  |
|         | 1994                         | Reserved                                 |  |
|         | 1995                         |  |  |
|         | 1996                         | Reserved                                 |  |
|         | 1997                         |  |  |
|         | 1998                         |  |  |
|         | 1999                         |  |  |
| FA      | 2000                         | Reserved                                 |  |
|         | 2001                         |  |  |
|         | 2002                         |  |  |
|         | 2003                         |  |  |
|         | 2004                         |  |  |
|         | 2005                         |  |  |
|         | 2006                         |  |  |
|         | 2007                         |  |  |
| FB      | 2008                         | Reserved                                 |  |
|         | 2009                         |  |  |
|         | 2010                         |  |  |
|         | 2011                         |  |  |
|         | 2012                         |  |  |
|         | 2013                         |  |  |
|         | 2014                         |  |  |
|         | 2015                         |  |  |
| FC      | 2016                         | Reserved                                 |  |
|         | 2017                         |  |  |
|         | 2018                         |  |  |
|         | 2019                         |  |  |
|         | 2020                         |  |  |
|         | 2021                         |  |  |
|         | 2022                         |  |  |
|         | 2023                         |  |  |
| FD      | 2024                         | I <sup>2</sup> C slave address           |  |
|         | 2025                         |  |  |
|         | 2026                         |  |  |
|         | 2027                         |  |  |
|         | 2028                         | Slave address selection bit0             | 0: from register [2024]<br>1: from GPIO0 |
|         | 2029                         | Slave address selection bit1             | 0: from register [2025]<br>1: from GPIO2 |
|         | 2030                         | Slave address selection bit2             | 0: from register [2026]<br>1: from GPIO4 |
| 2031    | Slave address selection bit3 | 0: from register [2027]<br>1: from GPIO5 |  |

# SLG46855-A

## Auto AEC-Q100 Qualified GreenPAK Programmable Mixed-Signal Matrix

**Table 57: Register Map (Continued)**

| Address |              | Signal Function           | Register Bit Definition   |
|---------|--------------|---------------------------|---|
| Byte    | Register Bit |                           |   |
| FE      | 2032         | I2C operation disable bit | 0: I2C operation enable; matrix in 32(33) select I2C_virtual_0(1) Input<br>1: I2C operation disable; matrix in 32(33) select GPIO0(GPIO1) digital input |
|         | 2033         | Reserved                  |   |
|         | 2034         | Reserved                  |   |
|         | 2035         | Reserved                  |   |
|         | 2036         | Reserved                  |   |
|         | 2037         | Reserved                  |   |
|         | 2038         | Reserved                  |   |
|         | 2039         | Reserved                  |   |
| FF      | 2040         | Reserved                  |   |
|         | 2041         |                           |   |
|         | 2042         |                           |   |
|         | 2043         |                           |   |
|         | 2044         |                           |   |
|         | 2045         |                           |   |
|         | 2046         |                           |   |
|         | 2047         |                           |   |



SLG46855-A

Auto AEC-Q100 Qualified GreenPAK Programmable  
Mixed-Signal Matrix

18 Package Top Marking Definitions

18.1 FCQFN 14L 3MM X 3 MM 0.65P FCD

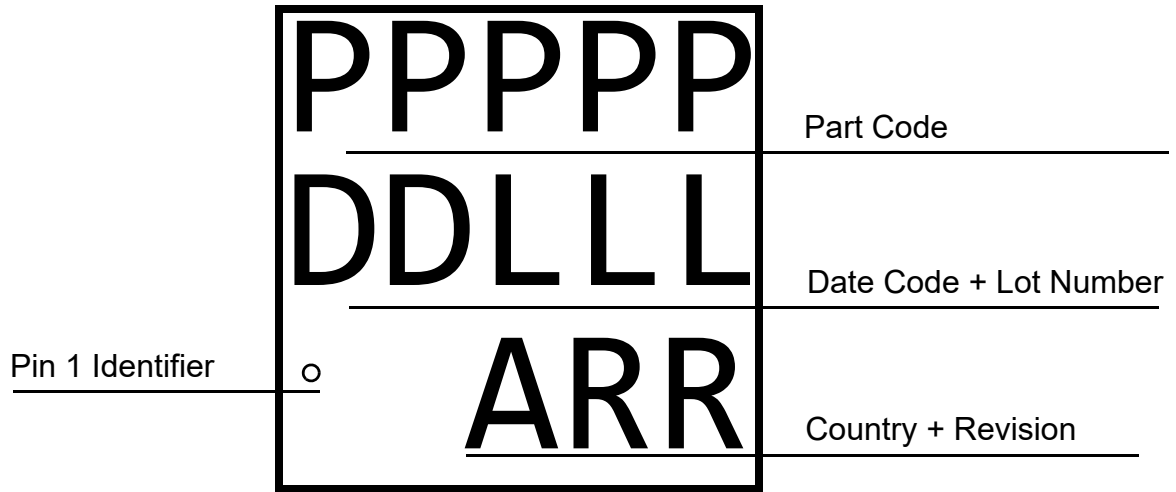

# SLG46855-A

## Auto AEC-Q100 Qualified GreenPAK Programmable Mixed-Signal Matrix

### 19 Package Information

#### 19.1 PACKAGE OUTLINES FOR FCQFN 14L 3.0 MM X 3.0 MM X 0.55 MM 0.65P FC PACKAGE

JEDEC MO-220  
IC Net Weight: 0.0115 g

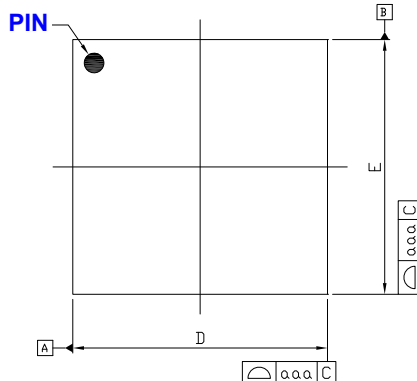

**Top View**

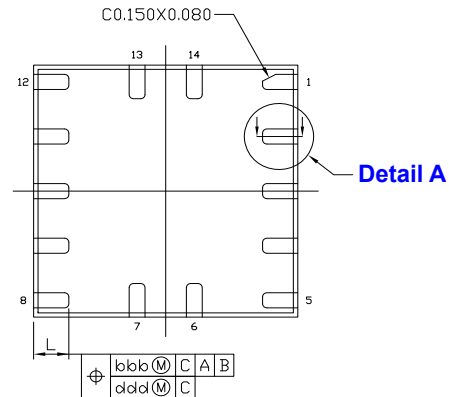

**Bottom View**

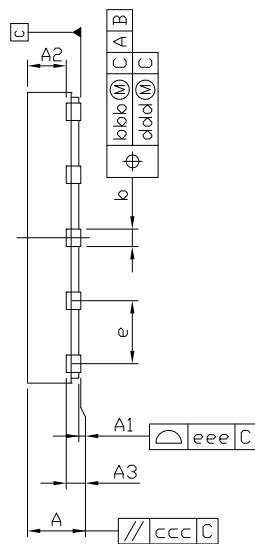

**Marking View**

#### Wettable Flank

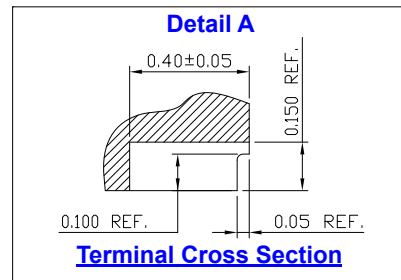

**Terminal Cross Section**

#### Controlling Dimensions: mm

| SYMBOLS | MILLIMETER |      |      | INCH      |       |       |
|---------|------------|------|------|-----------|-------|-------|
|         | MIN.       | NOM. | MAX. | MIN.      | NOM.  | MAX.  |
| A       | 0.50       | 0.55 | 0.60 | 0.020     | 0.022 | 0.024 |
| A1      | 0.00       | 0.02 | 0.05 | 0.000     | 0.001 | 0.002 |
| A2      | 0.35       | 0.40 | 0.45 | 0.014     | 0.016 | 0.018 |
| A3      | 0.10       | 0.15 | 0.20 | 0.004     | 0.006 | 0.008 |
| b       | 0.13       | 0.18 | 0.23 | 0.005     | 0.007 | 0.009 |
| D       | 2.95       | 3.00 | 3.05 | 0.116     | 0.118 | 0.120 |
| E       | 2.95       | 3.00 | 3.05 | 0.116     | 0.118 | 0.120 |
| e       | 0.65 BSC   |      |      | 0.026 BSC |       |       |
| L       | 0.35       | 0.40 | 0.45 | 0.014     | 0.016 | 0.018 |
| aaa     | 0.07       |      |      | 0.003     |       |       |
| bbb     | 0.07       |      |      | 0.003     |       |       |
| ccc     | 0.10       |      |      | 0.004     |       |       |
| ddd     | 0.05       |      |      | 0.002     |       |       |
| eee     | 0.08       |      |      | 0.003     |       |       |

Standard Tolerance: ±0.05

# SLG46855-A

## Auto AEC-Q100 Qualified GreenPAK Programmable Mixed-Signal Matrix

### 19.2 FCQFN HANDLING

Be sure to handle FCQFN package only in a clean, ESD-safe environment. Tweezers or vacuum pick-up tools are suitable for handling. Do not handle FCQFN package with fingers as this can contaminate the package pins and interface with solder reflow.

### 19.3 SOLDERING INFORMATION

Please see IPC/JEDEC J-STD-020: latest revision for re-flow profile based on package volume of 2.64 mm<sup>3</sup> (nominal) for FCQFN 14L Package. More information can be found at [www.jedec.org](http://www.jedec.org).

## 20 Ordering Information

| Part Number   | Type                                    |
|---------------|---|
| SLG46855-AP   | 14-pin FCQFN                            |
| SLG46855-APTR | 14-pin FCQFN - Tape and Reel (5k units) |

**Note 1** Use SLG46855-AP to order. Shipments are automatically in Tape and Reel.

**Note 2** "TR" suffix is no longer used. It is a legacy naming convention shown here only for informational purposes.

### 20.1 TAPE AND REEL SPECIFICATIONS

| Package Type                               | # of Pins | Nominal Package Size (mm) | Max Units |         | Reel & Hub Size (mm) | Leader (min) |             | Trailer (min) |             | Tape Width (mm) | Part Pitch (mm) |
|--|-----------|---------------------------|-----------|---------|----------------------|--------------|-------------|---------------|-------------|-----------------|-----------------|
|  |           |                           | per Reel  | per Box |                      | Pockets      | Length (mm) | Pockets       | Length (mm) |                 |                 |
| FCQFN 14L<br>3 mm x 3 mm<br>0.65P FC Green | 14        | 3.0 x 3.0 x 0.55          | 5000      | 10000   | 330/102              | 50           | 400         | 50            | 400         | 12              | 8               |

### 20.2 CARRIER TAPE DRAWING AND DIMENSIONS

| Package Type                                   | Pocket BTM Length (mm) | Pocket BTM Width (mm) | Pocket Depth (mm) | Index Hole Pitch (mm) | Pocket Pitch (mm) | Index Hole Diameter (mm) | Index Hole to Tape Edge (mm) | Index Hole to Pocket Center (mm) | Tape Width (mm) |
|--|------------------------|-----------------------|-------------------|-----------------------|-------------------|--------------------------|------------------------------|----------------------------------|-----------------|
|  | A0                     | B0                    | K0                | P0                    | P1                | D0                       | E                            | F                                | W               |
| FCQFN 14L<br>3.0 mm x 3.0 mm<br>0.65P FC Green | 3.3                    | 3.3                   | 0.8               | 4                     | 8                 | 1.5                      | 1.75                         | 5.5                              | 12              |

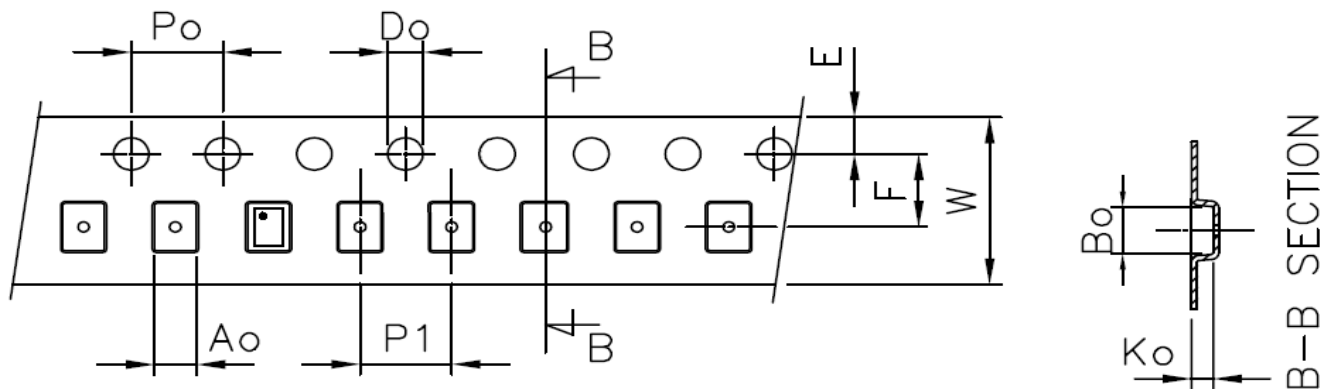



SLG46855-A

Auto AEC-Q100 Qualified GreenPAK Programmable Mixed-Signal Matrix

21 Layout Guidelines

21.1 FCQFN 14L 3 MM X 3 MM X 0.5 MM 0.65P FC GREEN

Expose Pad  (Package face down)

Recommended Landing Pattern  (Package face down)

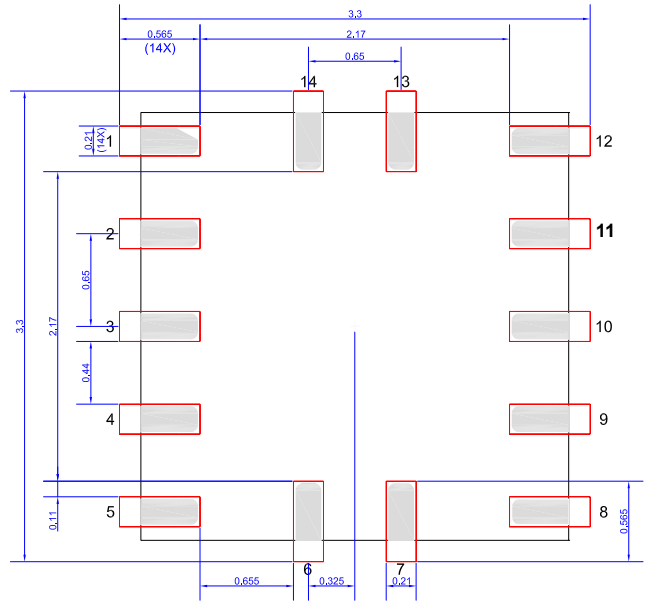
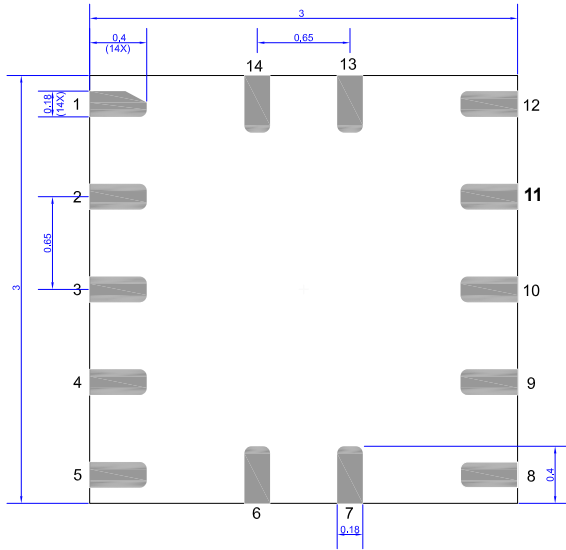

Unit: mm

## SLG46855-A

### Auto AEC-Q100 Qualified GreenPAK Programmable Mixed-Signal Matrix

#### Glossary

##### A

|       |                                    |
|-------|------------------------------------|
| ACK   | Acknowledge bit                    |
| ACMP  | Analog Comparator                  |
| ACMPH | Analog Comparator High Speed       |
| ACMPL | Analog Comparator Low Power        |
| ADAS  | Advanced Driver Assistance Systems |

##### B

|    |         |
|----|---------|
| BG | Bandgap |
|----|---------|

##### C

|     |                          |
|-----|--------------------------|
| CLK | Clock                    |
| CMO | Connection matrix output |
| CNT | Counter                  |

##### D

|     |             |
|-----|-------------|
| DFF | D Flip-Flop |
| DLY | Delay       |

##### E

|     |                         |
|-----|-------------------------|
| ESD | Electrostatic discharge |
| EV  | End Value               |

##### F

|     |                      |
|-----|----------------------|
| FSM | Finite State Machine |
|-----|----------------------|

##### G

|      |                              |
|------|------------------------------|
| GPI  | General Purpose Input        |
| GPIO | General Purpose Input/Output |
| GPO  | General Purpose Output       |

##### I

|    |              |
|----|--------------|
| IN | Input        |
| IO | Input/Output |

##### L

|     |                       |
|-----|-----------------------|
| LPF | Low Pass Filter       |
| LSB | Least Significant Bit |

## SLG46855-A

### Auto AEC-Q100 Qualified GreenPAK Programmable Mixed-Signal Matrix

LUT            Look Up Table  
 LV             Low Voltage

#### M

MSB           Most Significant Bit  
 MUX           Multiplexer

#### N

NPR           Non-Volatile Memory Read/Write/Erase Protection  
 nRST          Reset  
 NVM           Non-Volatile Memory

#### O

OD             Open-Drain  
 OE             Output Enable  
 OSC           Oscillator  
 OTP           one time programmable  
 OUT           Output

#### P

PD             Power-down  
 PGen          Pattern Generator  
 POR           Power-On Reset  
 PP             Push-Pull  
 PWR           Power  
 P DLY         Programmable Delay

#### R

R/W           Read/Write

#### S

SCL           I<sup>2</sup>C Clock Input  
 SDA           I<sup>2</sup>C Data Input/Output  
 SLA           Slave Address  
 SMT           With Schmitt Trigger  
 SV             nSET Value

#### T

TS             Temperature Sensor

## SLG46855-A

---

### Auto AEC-Q100 Qualified GreenPAK Programmable Mixed-Signal Matrix

#### V

Vref            Voltage Reference

#### W

WOSMT        Without Schmitt Trigger

WS             Wake and Sleep Controller

**Auto AEC-Q100 Qualified GreenPAK Programmable  
Mixed-Signal Matrix**
**Revision History**

| Revision | Date        | Description  |
|----------|-------------|--|
| 3.5      | 23-May-2023 | Updated tables captions in section Characteristics<br>Updated information in table Recommended Operating Conditions<br>Fixed typos   |
| 3.4      | 28-Feb-2023 | Added notes to section Ordering Information  |
| 3.3      | 13-Dec-2022 | Added additional information about AEC-Q100  |
| 3.2      | 19-Oct-2022 | Fixed typos in sections Layout Guidelines and Characteristics  |
| 3.1      | 7-Mar-2022  | Updated $R_{PULL}$ in section Electrical Characteristics<br>Renesas rebranding<br>Added IC Net Weight in Package Information section<br>Updated bytes 5B, 5C, 5D, 5E and 5F in the Register map<br>Added information about SCL and SDA Pins' Schmitt Trigger<br>Updated section GPIO8 Source for Oscillator 2 (25 MHz) |
| 3.0      | 17-Jun-2021 | Final version  |



## SLG46855-A

### Auto AEC-Q100 Qualified GreenPAK Programmable Mixed-Signal Matrix

#### Status Definitions

| Revision | Datasheet Status | Product Status | Definition   |
|----------|------------------|----------------|--|
| 1.<n>    | Target           | Development    | This datasheet contains the design specifications for product development. Specifications may change in any manner without notice.   |
| 2.<n>    | Preliminary      | Qualification  | This datasheet contains the specifications and preliminary characterization data for products in pre-production. Specifications may be changed at any time without notice in order to improve the design.  |
| 3.<n>    | Final            | Production     | This datasheet contains the final specifications for products in volume production. The specifications may be changed at any time in order to improve the design, manufacturing and supply. Major specification changes are communicated via Customer Product Notifications. Datasheet changes are communicated via <a href="http://www.renesas.com">www.renesas.com</a> . |
| 4.<n>    | Obsolete         | Archived       | This datasheet contains the specifications for discontinued products. The information is provided for reference only.  |

#### RoHS Compliance

Renesas Electronics Corporation's suppliers certify that its products are in compliance with the requirements of Directive 2011/65/EU of the European Parliament on the restriction of the use of certain hazardous substances in electrical and electronic equipment. RoHS certificates from our suppliers are available on request.

## Notice

1. Descriptions of circuits, software and other related information in this document are provided only to illustrate the operation of semiconductor products and application examples. You are fully responsible for the incorporation or any other use of the circuits, software, and information in the design of your product or system. Renesas Electronics disclaims any and all liability for any losses and damages incurred by you or third parties arising from the use of these circuits, software, or information.
2. Renesas Electronics hereby expressly disclaims any warranties against and liability for infringement or any other claims involving patents, copyrights, or other intellectual property rights of third parties, by or arising from the use of Renesas Electronics products or technical information described in this document, including but not limited to, the product data, drawings, charts, programs, algorithms, and application examples.
3. No license, express, implied or otherwise, is granted hereby under any patents, copyrights or other intellectual property rights of Renesas Electronics or others.
4. You shall be responsible for determining what licenses are required from any third parties, and obtaining such licenses for the lawful import, export, manufacture, sales, utilization, distribution or other disposal of any products incorporating Renesas Electronics products, if required.
5. You shall not alter, modify, copy, or reverse engineer any Renesas Electronics product, whether in whole or in part. Renesas Electronics disclaims any and all liability for any losses or damages incurred by you or third parties arising from such alteration, modification, copying or reverse engineering.
6. Renesas Electronics products are classified according to the following two quality grades: "Standard" and "High Quality". The intended applications for each Renesas Electronics product depends on the product's quality grade, as indicated below.
  - "Standard": Computers; office equipment; communications equipment; test and measurement equipment; audio and visual equipment; home electronic appliances; machine tools; personal electronic equipment; industrial robots; etc.
  - "High Quality": Transportation equipment (automobiles, trains, ships, etc.); traffic control (traffic lights); large-scale communication equipment; key financial terminal systems; safety control equipment; etc.
- Unless expressly designated as a high reliability product or a product for harsh environments in a Renesas Electronics data sheet or other Renesas Electronics document, Renesas Electronics products are not intended or authorized for use in products or systems that may pose a direct threat to human life or bodily injury (artificial life support devices or systems; surgical implantations; etc.), or may cause serious property damage (space system; undersea repeaters; nuclear power control systems; aircraft control systems; key plant systems; military equipment; etc.). Renesas Electronics disclaims any and all liability for any damages or losses incurred by you or any third parties arising from the use of any Renesas Electronics product that is inconsistent with any Renesas Electronics data sheet, user's manual or other Renesas Electronics document.
7. No semiconductor product is absolutely secure. Notwithstanding any security measures or features that may be implemented in Renesas Electronics hardware or software products, Renesas Electronics shall have absolutely no liability arising out of any vulnerability or security breach, including but not limited to any unauthorized access to or use of a Renesas Electronics product or a system that uses a Renesas Electronics product. RENESAS ELECTRONICS DOES NOT WARRANT OR GUARANTEE THAT RENESAS ELECTRONICS PRODUCTS, OR ANY SYSTEMS CREATED USING RENESAS ELECTRONICS PRODUCTS WILL BE INVULNERABLE OR FREE FROM CORRUPTION, ATTACK, VIRUSES, INTERFERENCE, HACKING, DATA LOSS OR THEFT, OR OTHER SECURITY INTRUSION ("Vulnerability Issues"). RENESAS ELECTRONICS DISCLAIMS ANY AND ALL RESPONSIBILITY OR LIABILITY ARISING FROM OR RELATED TO ANY VULNERABILITY ISSUES. FURTHERMORE, TO THE EXTENT PERMITTED BY APPLICABLE LAW, RENESAS ELECTRONICS DISCLAIMS ANY AND ALL WARRANTIES, EXPRESS OR IMPLIED, WITH RESPECT TO THIS DOCUMENT AND ANY RELATED OR ACCOMPANYING SOFTWARE OR HARDWARE, INCLUDING BUT NOT LIMITED TO THE IMPLIED WARRANTIES OF MERCHANTABILITY, OR FITNESS FOR A PARTICULAR PURPOSE.
8. When using Renesas Electronics products, refer to the latest product information (data sheets, user's manuals, application notes, "General Notes for Handling and Using Semiconductor Devices" in the reliability handbook, etc.), and ensure that usage conditions are within the ranges specified by Renesas Electronics with respect to maximum ratings, operating power supply voltage range, heat dissipation characteristics, installation, etc. Renesas Electronics disclaims any and all liability for any malfunctions, failure or accident arising out of the use of Renesas Electronics products outside of such specified ranges.
9. Although Renesas Electronics endeavors to improve the quality and reliability of Renesas Electronics products, semiconductor products have specific characteristics, such as the occurrence of failure at a certain rate and malfunctions under certain use conditions. Unless designated as a high reliability product or a product for harsh environments in a Renesas Electronics data sheet or other Renesas Electronics document, Renesas Electronics products are not subject to radiation resistance design. You are responsible for implementing safety measures to guard against the possibility of bodily injury, injury or damage caused by fire, and/or danger to the public in the event of a failure or malfunction of Renesas Electronics products, such as safety design for hardware and software, including but not limited to redundancy, fire control and malfunction prevention, appropriate treatment for aging degradation or any other appropriate measures. Because the evaluation of microcomputer software alone is very difficult and impractical, you are responsible for evaluating the safety of the final products or systems manufactured by you.
10. Please contact a Renesas Electronics sales office for details as to environmental matters such as the environmental compatibility of each Renesas Electronics product. You are responsible for carefully and sufficiently investigating applicable laws and regulations that regulate the inclusion or use of controlled substances, including without limitation, the EU RoHS Directive, and using Renesas Electronics products in compliance with all these applicable laws and regulations. Renesas Electronics disclaims any and all liability for damages or losses occurring as a result of your noncompliance with applicable laws and regulations.
11. Renesas Electronics products and technologies shall not be used for or incorporated into any products or systems whose manufacture, use, or sale is prohibited under any applicable domestic or foreign laws or regulations. You shall comply with any applicable export control laws and regulations promulgated and administered by the governments of any countries asserting jurisdiction over the parties or transactions.
12. It is the responsibility of the buyer or distributor of Renesas Electronics products, or any other party who distributes, disposes of, or otherwise sells or transfers the product to a third party, to notify such third party in advance of the contents and conditions set forth in this document.
13. This document shall not be reprinted, reproduced or duplicated in any form, in whole or in part, without prior written consent of Renesas Electronics.
14. Please contact a Renesas Electronics sales office if you have any questions regarding the information contained in this document or Renesas Electronics products.

(Note1) "Renesas Electronics" as used in this document means Renesas Electronics Corporation and also includes its directly or indirectly controlled subsidiaries.

(Note2) "Renesas Electronics product(s)" means any product developed or manufactured by or for Renesas Electronics.

(Rev.5.0-1 October 2020)

## Corporate Headquarters

TOYOSU FORESIA, 3-2-24 Toyosu,  
Koto-ku, Tokyo 135-0061, Japan  
[www.renesas.com](http://www.renesas.com)

## Trademarks

Renesas and the Renesas logo are trademarks of Renesas Electronics Corporation. All trademarks and registered trademarks are the property of their respective owners.

## Contact Information

For further information on a product, technology, the most up-to-date version of a document, or your nearest sales office, please visit:  
[www.renesas.com/contact/](http://www.renesas.com/contact/)