



# EV6604A-V-00A

## 45V, 2.5A, Simple Dual H-Bridge Driver (IN/EN), Evaluation Board

### DESCRIPTION

The EV6604A-V-00A evaluation board is designed to demonstrate the capabilities of the MP6604A, a dual H-bridge motor driver. It can be used to drive stepper motors, DC brushed motors, or other loads.

The MP6604A operates from an input voltage ( $V_{IN}$ ) of up to 45V, and can deliver load currents up to 2.5A per H-bridge.

The MP6604A has separate IN and EN pins for each output pin. The input control signals are generated on the board or come from an external controller via the connector on the board.

The MP6604A is available in a QFN-28 (4mmx5mm) package. It is recommended to read the MP6604A datasheet before making any changes to the EV6604A-V-00A.

### PERFORMANCE SUMMARY

Specifications are at  $T_A = 25^\circ\text{C}$ , unless otherwise noted.

Parameters	Conditions	Value
Input voltage ( $V_{IN}$ ) range		4.5V to 45V
Maximum output current ( $I_{OUT}$ )		2.5A

### EV6604A-V-00A EVALUATION BOARD



LxW (6.35cmx6.35cm)

Board Number	MPS IC Number
EV6604A-V-00A	MP6604AGV

## QUICK START GUIDE

1. Connect the input voltage ( $4.5V \leq V_{IN} \leq 45V$ ) and input ground to the VIN and GND connectors, respectively.
2. Connect the VCC voltage ( $V_{CC} = 3.3V$  or  $5V$ ) and input ground to the VCC and GND connectors, respectively.
3. Set the input control and logic signal through the CN1 connector via the external MCU, or manually through SW1. Table 1 shows the input logic for the EN (xENx) and IN (xINx) inputs.

**Table 1: Input Logic Truth**

xENx	xINx	xOUTx
1	X <sup>(1)</sup>	Hi-Z
0	0	L
0	1	H

**Note:**

- 1) X denotes 0 or 1.

**EVALUATION BOARD SCHEMATIC**

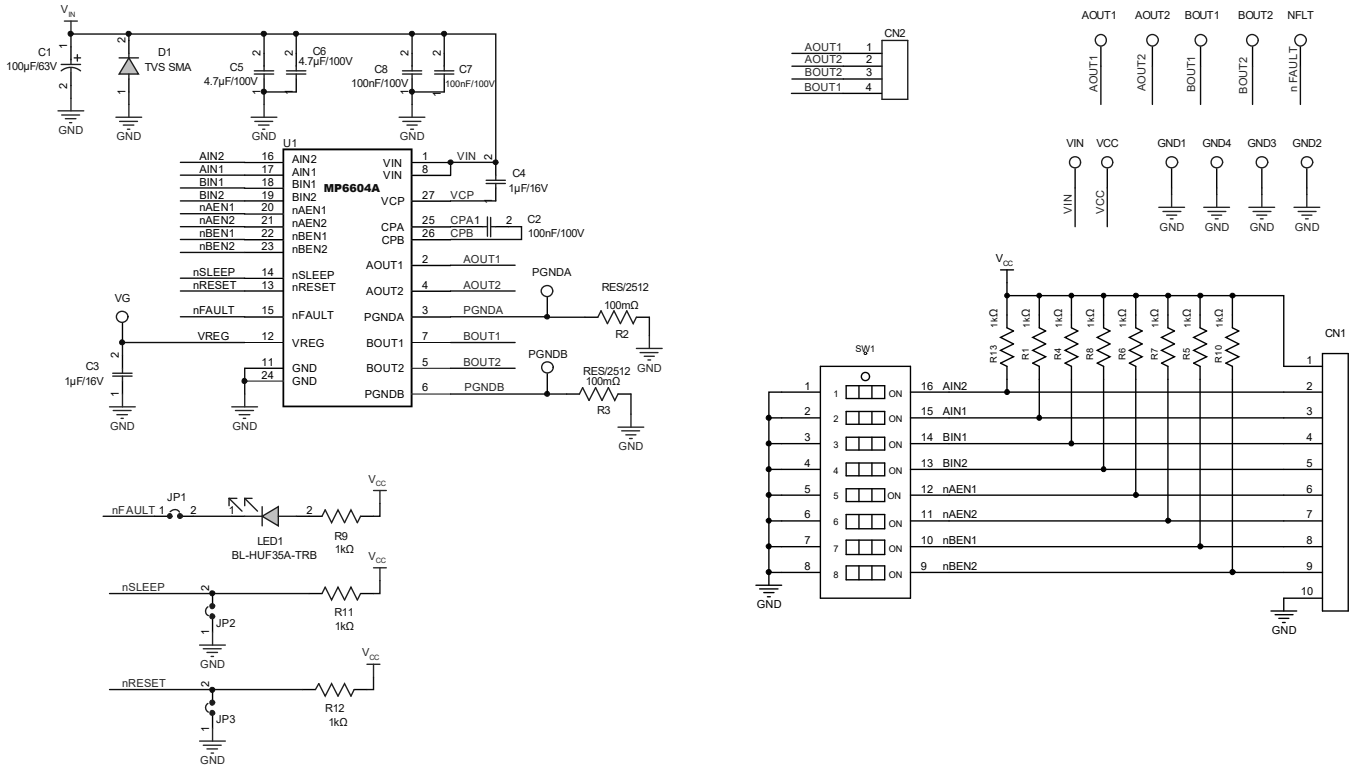

**Figure 1: Evaluation Board Schematic**

**EV6604A-V-00A BILL OF MATERIALS**

Qty	Ref	Value	Description	Package	Manufacturer	Manufacturer PN
1	C1	100µF	Electrolytic capacitor, 63V	DIP	Rubycon	63PX100MEFC8X11.5
3	C2, C7, C8	100nF	Ceramic capacitor, 100V, X7R	0603	Wurth	885012206120
2	C3, C4	1µF	Ceramic capacitor, 16V, X7R	0603	Murata	GRM188R71C105KA12D
2	C5, C6	4.7µF	Ceramic capacitor, 100V, X7S	1210	TDK	C3225X7S2A475K
11	R1, R4, R5, R6, R7, R8, R9, R10, R11, R12, R13	1kΩ	Film resistor, 1%	0603	Yageo	RC0603FR-071KL
2	R2, R3	100mΩ	Film resistor, 1%	2512	Yageo	RL2512FK-070R1L
1	LED1	20mA	Red LED	0805	Baihong	BL-HUE35A-AV-TRB
1	D1	NS				
1	SW1	25mA	Button	SMD	Wurth	418121270808
1	CN1	2.54mm	Connector, 10-bit	DIP	Any	
1	CN2	2.54mm	Connector, 4-bit	DIP	Any	
3	JP1, JP2, JP3	2.54mm	Connector, 2-bit	DIP	Any	
1	JP1	2.54mm	Short jumper	DIP	Any	
4	VG, NFLT, PGNDA, PGNDB	1mm	Test point	DIP	Any	
2	VIN, GND	2mm	Connector	DIP	Any	
8	VCC, GND, AOUT1, AOUT2, BOUT1, BOUT2, GND, GND	1mm	Connector	DIP	Any	
1	U1	MP6604A	45V, 2.5A, dual H-bridge driver (IN/EN)	QFN-28 (4mmx5mm)	MPS	MP6604AGV

### PCB LAYOUT

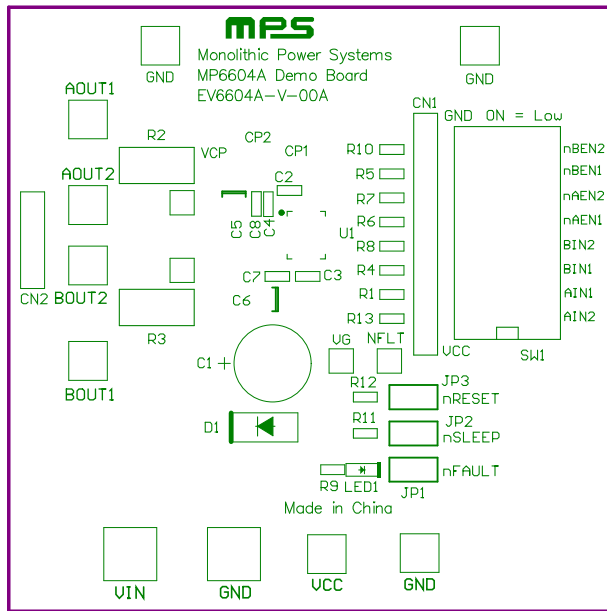

Figure 2: Top Silk

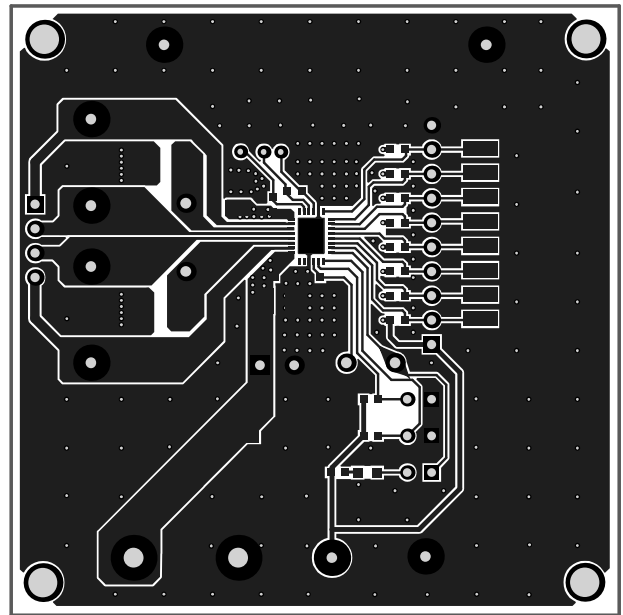

Figure 3: Top Layer

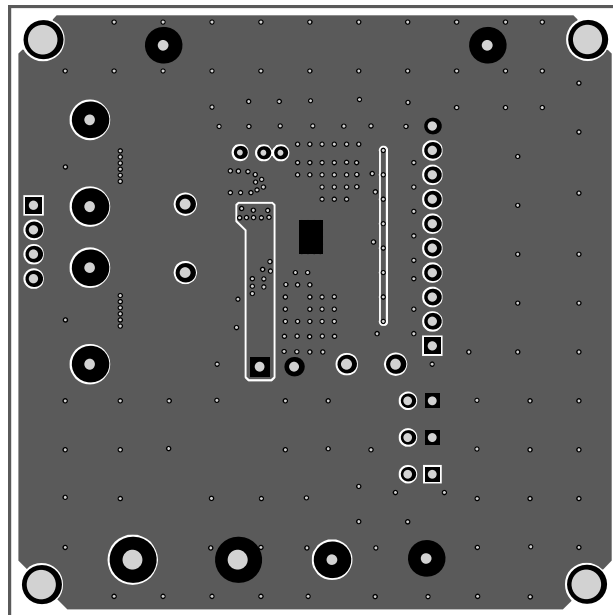

Figure 4: Bottom Layer



## REVISION HISTORY

Revision #	Revision Date	Description	Pages Updated
1.0	5/5/2022	Initial Release	-

**Notice:** The information in this document is subject to change without notice. Please contact MPS for current specifications. Users should warrant and guarantee that third-party Intellectual Property rights are not infringed upon when integrating MPS products into any application. MPS will not assume any legal responsibility for any said applications.